

MODEL RANGE

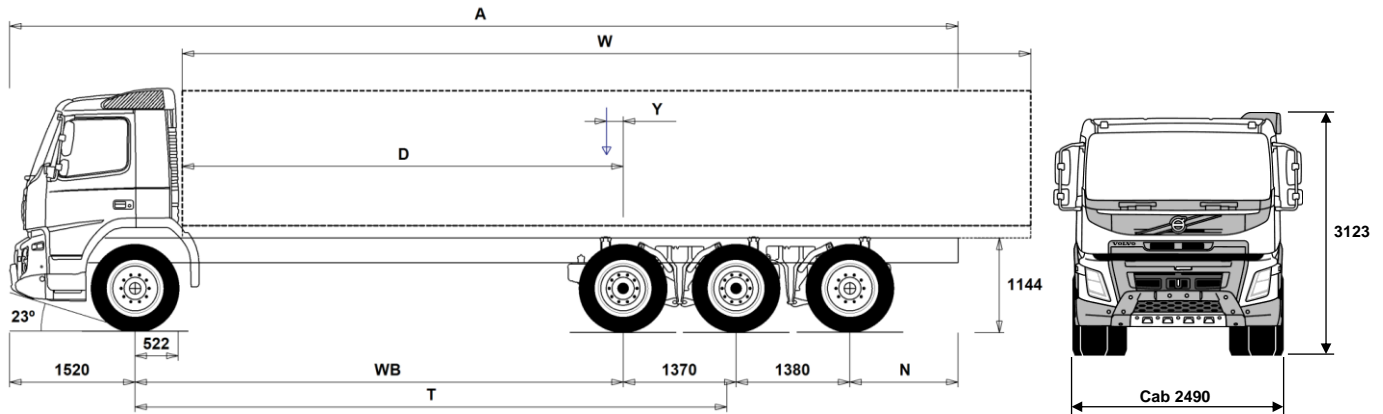

Volvo Trucks. Driving Progress

FMX D13 84 Rigid X-high tag tridem rear air FM 84 TR3CAX



Chassis Dimensions [mm]

WB Wheelbase	3200	3400	3700	3900	4100	4300	4600	4900	5200
A Overall Chassis Length	10165	10365	10665	10315	10665	10815	10965	11265	11515
D Center of rear axle to front of body	2628	2828	3128	3328	3528	3728	4028	4328	4628
N Rear Overhang (Min.)	1995	1995	1995	1995	1995	1995	1995	1995	1995
N Rear Overhang (Max.)	2695	2695	2695	2145	2295	2245	2095	2095	2045
T Theoretical Wheelbase	4459	4659	4959	5159	5359	5559	5859	6159	6459
Y Center of Gravity for Payload (Min.)	-678	-655	-621	-605	-580	-560	-530	-496	-464
Y Center of Gravity for Payload (Max.)	-678	-655	-621	-605	-580	-560	-530	-496	-464
W Body Length (Min.)	6611	6965	7496	7865	8216	8575	8940	9203	9463
W Body Length (Max.)	6611	6965	7496	7865	8216	8575	8940	9203	9463

Chassis Weights [kg]

Front Axle	4735	4755	4780	4825	4830	4860	4895	4915	4935
Rear Bogie	5210	5210	5210	5135	5155	5160	5165	5170	5165
Kerb Weight	9945	9965	9990	9960	9985	10020	10060	10085	10100
Payload (including body, driver, fuel, etc.)	25055	25035	25010	25040	25015	24980	24940	24915	24900

Turning Diameter [mm]

Turning Circle Diameter Kerb to Kerb	13900	14500	15500	16100	16700	17300	18200	19100	20000
Turning Circle Diameter Wall to Wall	15400	16000	16900	17500	18200	18800	19700	20600	21500

Plated Weights [kg]

	Design
Gross Vehicle Weight	35000
Gross Combination Weight	44000
Front Axle	8000
Rear Bogie	27000

Important Notes

Chassis Dimensions

Cab Height: +416 mm for CAB-HSLP.
 Front Axle to Back of Cab: +424 mm for CAB-HSLP and CAB-SLP.
 D-measure includes a front clearance of 50 mm and for rigid trucks also a subframe of 100 mm.
 Height can vary ± 20 mm for leaf and ± 10 mm for air suspension.
 All dimensions are for unladen chassis and any tag axles down.
 Rear overhang used for vehicle weight calculation is the maximum rear overhang (N Max.) for selected wheelbase.

Weight and dimensions are based upon the following tyres:

Front Axle Tyres:	315/80R22.5
Drive Axle Tyres:	315/80R22.5
Trailing/Pusher Axle Tyres:	315/80R22.5

Chassis weight includes oil, water, AdBlue, 0 litres fuel and without driver. Kerb weight can vary $\pm 3\%$.

Turning diameters are theoretically calculated. Tag axle used: TA-HYDRS.

Legal weights can differ from country to country.

For more detailed weight information, including optional equipment weights, ask your Volvo sales contact to enter your specification into the Volvo Weight Information system (WIS).

Do NOT use this drawing for bodybuilding. Refer to Volvo Bodybuilder Instructions and chassis assembly drawing FM84TR3CAX.

MODEL RANGE

FMX D13 84 Rigid X-high tag tridem rear air FM 84 TR3CAX

Transport operation

- **RC-ROUGH** Rough road conditions.
 - Less than 95% of the driven distance on well maintained or less maintained surfaced roads. and / or
 - In total not more than 5% of the driven distance on:
 - Very badly maintained surfaced roads.
 - Hard packed sand or gravel surface of very bad quality.
 - Washboards.
 - Soft unpaved surface.
 - Off-road.
- **GARB-PRE** Garbage preparation
- **TIPP-PRE** Tipper vehicle preparation
- **UNIFORM** Basic platform vehicle

Core components

- **CHH-XHIG** Chassis height extra high - approx. 1030 mm above ground level
- **TA-HYSBS** El. hydraulically steered tag axle with single wheels (two wheels on complete axle) and steering lock out at 38 km/h
- **RADDT-G2** Rear air suspension, 3 axles - 2 driven / 1 tag, high ground clearance
- **FMX-DAY** FMX Day cab
- **FMX-HSLP** FMX Globetrotter sleeper cab
- **FMX-SLP** FMX Sleeper cab
- **EU6SCR** Euro 6 emission level with Selective Catalytic Reduction (SCR), particulate filter and Exhaust Gas Recirculation (EGR)
- **D13 420S** Diesel engine with Turbo-S, 12.8 litre Euro 6 SCR + EGR (Diesel Particulate Filter), 420 hp, 2100 Nm
- **D13 460S** Diesel engine with Turbo-S, 12.8 litre Euro 6 SCR + EGR (Diesel Particulate Filter), 460 hp, 2300 Nm
- **D13 500S** Diesel engine with Turbo-S, 12.8 litre Euro 6 SCR + EGR (Diesel Particulate Filter), 500 hp, 2500 Nm
- **D13 540S** Diesel engine Turbo-S, 12.8 litre Euro 6 SCR + EGR (Diesel Particulate Filter), 540 hp, 2600 Nm
- **D13K420** Diesel engine, 12.8 litre Euro 6 SCR + EGR (Diesel Particulate Filter), 420 hp
- **D13K460** Diesel engine, 12.8 litre Euro 6 SCR + EGR (Diesel Particulate Filter), 460 hp
- **D13K500** Diesel engine, 12.8 litre Euro 6 SCR + EGR (Diesel Particulate Filter), 500 hp.
- **D13K540** Diesel engine, 12.8 litre Euro 6 SCR + EGR (Diesel Particulate Filter), 540 hp
- **DIESEL** Diesel fuel
- **DIESEL-B** Biodiesel
- **EBR-EPG** Engine brake with exhaust pressure governor, EPG
- **EBR-EPGC** Volvo engine compression brake with exhaust pressure governor, EPG (for I-shift)
- **EBR-VEB** Volvo Engine Brake, VEB (compression brake with exhaust pressure governor, EPG)
- **EBR-VEB+** Volvo Engine Brake, VEB+ (high efficiency compression brake with exhaust pressure governor, EPG)
- **AT2412F** I-Shift automated mechanical 12-speed gearbox without clutch pedal, max. engine torque 2400 Nm, max. permitted GCW 44000 kg.
- **AT2612F** I-Shift automated mechanical 12-speed gearbox without clutch pedal, max. engine torque 2600 Nm, max. permitted GCW 100000 kg.
- **ATO2612F** I-Shift automated mechanical 12-speed overdrive gearbox without clutch, max. engine torque 2600 Nm, max. permitted GCW 100000 kg. Suitable for hub reduction rear axles.
- **PT2606** Powertronic automatic 6-speed gearbox, max. engine torque 2600 Nm, max. permitted GCW 130000 kg
- **SPO2812** Semi power shift dual clutch 12-speed overdrive gearbox, max. engine torque 2800 Nm, max permitted GCW 80 000 kg.
- **RTH2610F** Rear hub reduction tandem axles - bogie load 26 tonnes, GCW 100 tonnes, version F
- **RTS2310A** Rear single reduction tandem axle - bogie load 23 tonnes,

■ Standard Equipment

□ Optional Equipment

For more detailed information about cab and powertrain equipment, please refer to separate specification sheets.

For all possible options and combinations of options please consult your Volvo sales contact who can create a specification to match your requirements using the Volvo Sales Support system (VSS).

The factory reserves the right to modify design and change equipment without previous notification. The specification can vary from country to country.

- **RTS2370A** GCW100 tonnes
Rear single reduction tandem axles - bogie load 23 tonnes, GCW 70 tonnes

Packages

- **EDITION** Exterior Striping/Emblem. Model specific design on FH,FM,FH16 and FMX
- **DRIVEFM** Driving package FM
- **DRIVEFM+** Driving plus package FM
- **BEDFM** Bed resting package FM
- **AUDBAS** Audio basic. RDS radio with CD player, FM/AM antenna and speakers in dashboard & doors.
Prepared for Dynafleet office internet portal support.
- **AUDHIG** High power audio system. RDS radio with CD player (also playing mp3/wma/wav files from CD), FM/AM antenna, speakers in dashboard & doors & sleeping compartment, integrated bluetooth phone and USB/Line inputs.
Prepared for Dynafleet office internet portal support.
- **MEDIADF** Media package with infotainment. Prepared for both Dynafleet vehicle onboard support and for Dynafleet office internet portal support.
- **MEDIANDF** Media package with infotainment and Navigation support and prepared for Dynafleet vehicle onboard support and for Dynafleet office internet portal support.
- **VISIX15** Visibility package FMX
- **ENOPT** Energy optimization package
- **ENOPT+** Energy optimization+ package
- **OFFRFMXD** Construction package for FMX day cab
- **OFFRFMXS** Construction package for FMX sleeper cabs
- **RCHAPAC1** Rigid chassis package

Chassis

- **FST-PAR3** 3 leaf front parabolic suspension (stiffer than normal)
- **FAL10.0** Front axle load 10.0 tonnes
- **FAL7.5** Front axle load 7.5 tonnes
- **FAL8.0** Front axle load 8.0 tonnes
- **FAL8.5** Front axle load 8.5 tonnes
- **FAL9.0** Front axle load 9.0 tonnes
- **FALIM** Front axle load limiter
- **FSTAB** Front stabilizer with normal stiffness
- **FSTAB2** Front stabilizer with medium high stiffness
- **FSTAB3** Front stiff stabilizer
- **RAL27** Rear axles load 27 tonnes
- **RAL33** Rear axles load 33 tonnes
- **RAL36** Rear axles load 36 tonnes
- **RSTAB3** Rear stiff stabilizer
- **RALIM105** First rear drive axle load limiter, 10.5 tonnes (speed controlled)
- **RALIM115** First rear drive axle load limiter, 11.5 tonnes (speed controlled)
- **RALIM13** First rear drive axle load limiter, 13 tonnes
- **RALIM95** First rear drive axle load limiter, 9.5 tonnes
- **ASF-DL1** Air suspension with 1 driving level
- **ASF-DL3** Air suspension with 3 driving levels
- **ACTST-TO** Volvo Dynamic Steering (VDS) with extra pump and torque overlay
- **ASFE-BAS** Volvo Dynamic Steering feature basic
- **ASFE-PS** Volvo Dynamic Steering personal settings
- **PSS-DUAL** Dual power steering system
- **PSS-SING** Single power steering system
- **PSP-VAR** Power steering pump with variable displacement
- **EBS-MED** EBS (Electronic Brake System) medium package:
 - ABS (Anti-lock Braking System)
 - Lining Wear Sensing (20 % left)
 - Lining Wear Control (incl. wear on the axle)
 - Brake Blending

MODEL RANGE

FMX D13 84 Rigid X-high tag tridem rear air FM 84 TR3CAX

- Drag Torque Control
- Diff Lock Synchronization
- Diff lock Control
- Brake Temperature Warning
- External Brake Demand
- Diagnosis Via Truck Electronic System
- Traction Control System
- Emergency Brake Assistance
- Constant Wheel Brake Monitoring
- Coupling Force Control
- Automatic Parking Brake Activation
- Lining Wear Analyses (calc of remaining mileage)
- Hill Starting Assistance
- EBS status monitoring via Truck Electronic System
- AUXPARK** Two extra parking brake chambers
- FBREG-E** Front axle regulating brake valve for EBS
- SUSPL-EC** Air suspension levelling with electronic control
- FRAME300** Frame rail section external height 300 mm
- FST7070** Frame section thickness - web 7.0 mm / flange 7.0 mm
- FST8080** Frame section thickness - web 8.0 mm / flange 8.0 mm
- FIL-EEEE** Frame inner liner from end of engine end to end of bogie
- FIL-EEEF** Frame inner liner from end of engine end to end of frame
- FIL-FBEB** Frame inner liner from front of bogie to end of bogie
- FIL-FBEF** Frame inner liner from front of bogie to end of frame
- FIL-TXEB** Frame inner liner from transmission cross member to end of bogie
- FIL-TXEF** Frame inner liner from transmission cross member to end of frame
- BBOX-L** Battery box on left hand side
- 2BAT210B** Gel batteries 2x210 Ah
- 2BATT170** Batteries 2x170 Ah
- 2BATT225** Batteries 2x225 Ah
- BATTAMP** Battery voltage and ampere gauge
- BATTIND** Battery voltage, ampere and battery status gauge with visual alerts
- ADR2** ADR adaptation - transportation of dangerous goods, 2 switches (1 inside cab in dashboard, 1 outside on cab back passenger side).
- MSWI-A** ADR main switch - ADR switch circuit shut down
- MSWI-C** Chassis main switch - battery box placed toggle switch circuit shut down
- MSWI-R** Remote controlled main switch - key fob operated circuit shut down
- R315A56** Right 315 litre aluminium 560 mm high D-shaped diesel tank. Usable volume is 97% of stated volume.
Min volume 255l
Max volume 810l
- UL-FUEL** Without left diesel tank
Min volume 160l
Max volume 730l
- ADTP-L** AdBlue tank on left hand side (for dual front axles between the axles)
- ADTP-R** AdBlue tank on right hand side
- ADB048** AdBlue tank usable volume 48 litres
- ADB064** AdBlue tank usable volume 64 litres
- ADB068** AdBlue tank usable volume 68 litres
- ADB090** AdBlue tank usable volume 90 litres
- ADB100** AdBlue tank usable volume 100 litres
- FCAP-L** Lockable diesel and AdBlue tank caps
- FUFF-AS** Fuel filling anti-spillage device
- FUFF-ATS** Fuel filling anti-theft and anti-spillage devices
- ESH-LEFT** Horizontal muffler, left exhaust outlet
- ESH-REAR** Horizontal muffler, rear exhaust outlet
- ESH-VERT** Horizontal muffler, vertical exhaust outlet on right hand side
- ESV-VERT** Vertical muffler, vertical exhaust outlet on right hand side
- EXST-SSP** Bright polished vertical stainless steel exhaust top pipe
- EXST-ST** Aluminized steel vertical exhaust top pipe
- HS-NAR** Narrow Euro 6 muffler heat shield. Partly (due to heat release) reduced distance (moved inwards) to silencer. Makes better space for e.g. support legs.
- WHC-FIX2** Two fixed wheel chocks
- WHC-FOL2** 2 foldable wheel chocks
- WHCP-F** Wheel chock(s) in the front part of the vehicle.
- TRACTOR, BBOX-L, Fold, 1/2 w chocks = Top of left side battery box
- TRACTOR, BBOX-EF, Fold, 1/2 w chocks = Top of lefts side fuel tank
- TRACTOR, BBOX-EF, Fix, 2 w chocks = Left frame front of fuel tank
- RIGID, 1 front axle, Fold, 1/2 w chocks = Top of left side battery box
- RIGID, 2 front axles, Fold, Frame free space, 2 wc = Top of left side battery box
- RIGID, 2 front axles, Fix, W/o frame free space, 2 wc = Left frame behind 1st front wheel
- WHCP-M** Wheel chock(s) in the middle part of the vehicle
- TRACTOR, BBOX-L, Fix, 1/2 w chocks = Left frame front of rear wheels
- RIGID, 1 front axle, Fix, 1/2 w chocks = Left frame front of (or behind) rear wheels
- WHCP-R** Wheel chock(s) in the rear part of the vehicle
- RIGID, 1 front axle, Fix, 1/2 w chocks = Left frame rear (or front) of rear wheels
- WHCP-T** Transport mounted wheel chock(s) in cab outer luggage compartment
- TB-L80** Left toolbox 800 mm length (mounting length 800 mm, real length 730 mm)
- TB-R80** Right toolbox 800 mm length (mounting length 800 mm, real length 730 mm)
- CHAIN-S** Snow chains
- HOOK-SC** Snow chain hooks.
Rear mounted for tractors and side mounted in rear overhang for rigids. Two hooks on each side.
- TOWF-HD1** One heavy duty front towing device
- TOWMBRH1** High mounted towing member, in centre of frame
- TOWMBRL1** Towing member, low mounted under the frame (position 1)
- TOWMBRM1** Towing member, medium mounted in line with frame lower flange
- RFEC-S** Rear frame end, straight cut (for regular platform applications)
- RFEC-U** Rear frame end, upper cut (for e.g. tipper, refuse and hooklift applications)
- C-RI4040** Towing coupling Ringfeder RF4040A G-150
- C-RI4045** Towing coupling Ringfeder RF4045A G-150
- C-RI5055** Towing coupling Ringfeder RF5055A G-150
- C-RO400G** Towing coupling Rockinger 400 G-150
- C-RO50** Towing coupling Rockinger 50 mm
- C-VBG750** Towing coupling VBG 750V
- C-VBG850** Towing coupling VBG 8500
- TOWR-ONE** One rear towing device in frame end cross member
- TREL-PK** Trailer electrical preparation kit (chassis/cab wiring)
- TREL15** 15 pol electrical trailer connector (ADR certified)
- TREL7-7** 2x7 pol (24N+24S) electrical trailer connectors (UADR)
- TBC-DUO** Trailer brake connection, Duomatic
- TBC-EC** Trailer brake connection, European Community
- TRBR-STA** Stationary trailer brake control
- TRB-STRE** Automatic low speed trailer brake activation (stretch brake) to avoid jack-knifing and to improve steerability
- RUP-FOSL** Foldable and slidable aluminium rear underrun protection, EC approved

Standard Equipment

Optional Equipment

For more detailed information about cab and powertrain equipment, please refer to separate specification sheets.

For all possible options and combinations of options please consult your Volvo sales contact who can create a specification to match your requirements using the Volvo Sales Support system (VSS).

The factory reserves the right to modify design and change equipment without previous notification. The specification can vary from country to country.

MODEL RANGE

FMX D13 84 Rigid X-high tag tridem rear air FM 84 TR3CAX

- RFEND-B** Rear 3 piece fenders with anti-spray function (all rear axles)
 - RFEND-T** Transport mounted one-piece rear fenders
 - RFH-BAS** Optimal fender installation (rear and 2nd front axle) with regard to legal demands, wheel/tyre sizes, chassis height and fifth wheel height.
 - RFH-HIG** Highest fender installation (rear and 2nd front axle). Suitable for rough and very rough road conditions.
 - RFH-LOW** Lower fender installation (rear and 2nd front axle). Suitable only for smooth road conditions. Increased risk of fender top wear.
 - AUXATNK** Extra air tank
 - ATANK-AL** Aluminium air tanks
 - ATANK-ST** Steel air tanks
 - TL-LED** LED tail lamps (tail light, exterior marker light, brake light, hazard warning light, reverse light, rear fog light, licence plate light and reflector).
 - BLIGHT-E** Emergency brake light
 - FRACLOS** Frame end closing
- ### Rims and Tyres
- RT-AL** Brushed aluminium rims with std holes (long stud fixing) on all axles
 - RT-ALDP** Dura-Bright polished aluminium rims with std holes (long stud fixing) on all axles
 - RT-ALDPD** Dura-Bright polished aluminium rims with countersunk holes (short stud fixing) on all axles
 - RT-ALDU** Brushed aluminium rims with countersunk holes (short stud fixing) on all axles
 - RT-STEEL** Steel rims on all axles
 - WCAP** Wheel caps
 - SPWT-D** Spare wheel with tyre equal to drive
 - SPWT-F** Spare wheel with tyre equal to front wheel
 - SWCP-LF** Spare wheel carrier on left side in front of rear axle
 - SWCP-R** Spare wheel carrier mounted behind rear axle and below frame
 - SWCP-T** Temporary spare wheel carrier. Spare wheel is transport mounted (strapped on top of the frame rails) with plastic stripes.
 - SWCP-TP** Spare wheel carrier transport mounted with the spare wheel on top of the frame rails
 - JACK-12T** Jack 12 tonnes
 - JACK-15T** Jack 15 tonnes
 - JACK-20T** Jack 20 tonnes
 - TOOL-BAS** Basic tools (combination screw driver, socket wrench)
 - TOOLKIT** Extended tool kit
 - INFLAHOS** Tyre inflation hose (18 metres) with nozzles in both ends
 - GAUGE-TP** Tyre pressure gauge
 - OBDEP-C** EU6 mandatory on board diagnostics, phase C regulations
 - OBDEP-D** EU6 mandatory on board diagnostics, phase D regulations
- ### Powertrain equipment
- ASO-C** One crawler gear
 - ASO-ULC** Two crawler gears, one ultra low crawler and one crawler
 - TRAP-HD** Reinforced gearbox application. For manual gearboxes a heavy-duty nodular iron range housing. For I-shift gearboxes (2412 excl.) a reinforced gear shifting system.
 - TP-BAS** I-shift City gear changing software
 - TP-CON** I-shift construction gear changing software
 - TP-DIST** I-shift distribution gear changing software
 - TP-HD** I-shift Heavy Duty gear changing software
 - TP-LONG** I-shift long haul gear changing software
 - AMSO-AUT** I-shift manual gear shift available in automatic mode incl kickdown function
 - AVO-ENH** Enhanced I-shift software for construction and off road applications
 - APF-ENH** Enhanced I-shift PTO functions (Auto Neutral / Reverse Inhibit / Split Box Connection)
 - CD43-O** Dual plate clutch, plate diameter 430 mm
 - RET-TH** Retarder (incl cooler) for manual and I-shift gearboxes with oil as brake fluid
 - RET-TPT** Retarder for hydraulic gearbox
 - TC-HWO** Cooler for hydraulic gearboxes - water/oil
 - TC-MAOH2** Extra high performance cooler for manual/I-shift gearboxes - air/oil
 - TC-MWO** Basic performance cooler for manual/I-Shift gearboxes - water/oil
 - TC-MWOH2** High performance cooler for manual/I-Shift gearboxes - water/oil
 - 2COM1100** Dual cylinder air compressor 760 cc / 1100 l/min
 - 2COMP900** Dual cylinder air compressor 636 cc
 - CLU-AIRC** Air compressor clutch automatically declutched when not needed in order to save fuel
 - AIRIN-HI** High air intake
 - AIRIN-LO** Low air intake
 - ACL1ST-S** Air cleaner with additional filter element (primary + secondary)
 - 24AL110B** Alternator 110 Ampere
 - 24AL120B** Alternator 120 Ampere
 - 24AL150B** Alternator 150 Ampere
 - CCV-C** Closed crankcase ventilation
 - CCV-O** Open crankcase ventilation
 - PRIM-EL** Electrical priming pump for fast and easy bleeding of the fuel system
 - PRIM-MAN** Manual priming pump for fast and easy bleeding of the fuel system
 - AF-R** Hot fuel recirculation heated fuel filter
 - EST-AID** Engine start pre-heating element
 - 220EBH15** Engine block heater, 220 volt, 1.5 kW
 - PTER-100** Rear engine mounted clutch independent power-take-off with flange connection (DIN 100 / ISO 7646)
 - PTER-DIN** Rear engine mounted clutch independent PTO with splined shaft groove (female) for a close coupled pump (DIN 5462 / ISO 7653)
 - PTER1400** Rear engine mounted clutch independent power-take-off with flange connection (SAE 1410 / ISO 7647)
 - HPE-F101** Rear engine mounted hydraulic pump F1-101, fixed displacement, single flow
 - HPE-F41** Rear engine mounted hydraulic pump F1-41, fixed displacement, single flow
 - HPE-F51** Rear engine mounted hydraulic pump F1-51, fixed displacement, single flow
 - HPE-F61** Rear engine mounted hydraulic pump F1-61, fixed displacement, single flow
 - HPE-F81** Rear engine mounted hydraulic pump F1-81, fixed displacement, single flow
 - HPE-T53** Rear engine mounted hydraulic pump F2-53/53, fixed displacement, twin flow
 - HPE-T70** Rear engine mounted hydraulic pump F2-70/35, fixed displacement, twin flow
 - HPE-V45** Rear engine mounted hydraulic pump VP1-45, variable displacement, single flow
 - HPE-V75** Rear engine mounted hydraulic pump VP1-75, variable displacement, single flow
 - PTPT-D** Automatic gearbox driven power take-off, 1 front/upper connection (DIN 5462 / ISO 7653) for plug-in pump (max. 850 Nm).
 - PTPT-F** Automatic gearbox driven Power take-off, 1 front/upper rear facing flange connection (SAE 1410 / ISO 7647) for propeller shaft (max. 850 Nm).
 - PTR-D** Mechanical gearbox driven low speed power take-off, 1 rear connection (DIN 5462 / ISO 7653) for plug-in pump (max. 1000 Nm).

Standard Equipment

Optional Equipment

For more detailed information about cab and powertrain equipment, please refer to separate specification sheets.

For all possible options and combinations of options please consult your Volvo sales contact who can create a specification to match your requirements using the Volvo Sales Support system (VSS).

The factory reserves the right to modify design and change equipment without previous notification. The specification can vary from country to country.

MODEL RANGE

FMX D13 84 Rigid X-high tag tridem rear air FM 84 TR3CAX

- **PTR-DH** Nm). Mechanical gearbox driven high speed power take-off, 1 rear connection (DIN 5462 / ISO 7653) for plug-in pump (max. 600 Nm).
 - **PTR-DM** Mechanical gearbox driven medium speed power take-off, 1 rear connection (DIN 5462 / ISO 7653) for plug-in pump (max. 600 Nm).
 - **PTR-F** Mechanical gearbox driven low speed power take-off, 1 rear flange connection (SAE 1410 / ISO 7647) for propeller shaft (max. 1000 Nm).
 - **PTR-FH** Mechanical gearbox driven high speed power take-off, 1 rear flange connection (SAE 1310 / ISO 7647) for propeller shaft (max. 600 Nm).
 - **PTR-FL** Mechanical gearbox driven low speed power take-off, 1 rear flange connection (SAE 1310 / ISO 7647) for propeller shaft (max. 600 Nm).
 - **PTRD-D** Mechanical gearbox driven high speed power take-off, 1 rear and 1 front connections (DIN 5462 / ISO 7653) for plug-in pumps (max. 870 Nm).
 - **PTRD-D1** Mechanical gearbox driven high speed power take-off, 1 rear flange connection (SAE 1410 / ISO 7647) for propeller shaft / 1 front connection (DIN 5462 / ISO 7653) for plug-in pump (max. 870 Nm).
 - **PTRD-D2** Mechanical gearbox driven power take-off, 2 rear flange (high-low speed) connections (SAE 1310/1410 / ISO 7647) for propeller shafts / 1 front (high speed) connection (DIN 5462 / ISO 7653) for plug-in pump (max. 870/1000 Nm).
 - **PTRD-F** Mechanical gearbox driven high speed power take-off, 1 rear flange connection (SAE 1410 / ISO 7647) for propeller shaft (max. 870 Nm).
 - **HPG-F101** Gearbox mounted hydraulic pump F1-101, fixed displacement, single flow
 - **HPG-F41** Gearbox mounted hydraulic pump F1-41, fixed displacement, single flow
 - **HPG-F51** Gearbox mounted hydraulic pump F1-51, fixed displacement, single flow
 - **HPG-F61** Gearbox mounted hydraulic pump F1-61, fixed displacement, single flow
 - **HPG-F81** Gearbox mounted hydraulic pump F1-81, fixed displacement, single flow
 - **EIDLESD** Engine idle shut down
- Cab Interior, Driving**
- **STWPOS-L** Left hand drive
 - **STWM-LE** Leather steering wheel
 - **STGW-AD2** Mechanically adjustable steering wheel with neck tilt
 - **STGW-ADJ** Mechanically adjustable steering wheel
 - **AIRBAG** Airbag on driver side
 - **INST-BAS** Basic level instrument cluster - 4 inch monochrome display 240x320 pix
 - **DRC-AMII** Regeneration control of diesel filter particulates - auto initiation / manual on demand / manual inhibition
 - **DRC-AUTO** Regeneration control of diesel filter particulates - fully automatic (in motion)
 - **1DAYDIG** One day digital tachograph, EC approved
 - **1DAYDIG2** Gen 2 one day digital tachograph, EC approved
 - **1DAYDIGP** One day digital tachograph, EC approved + Prep Kit for TAS-DIG2
 - **ARSL** Additional road speed limiter (switch in dashboard)
 - **CRUIS-E** Cruise control I-Cruise with controls in the steering wheel, I-Roll incl. Adding PVT-EXT/-MAP give I-See.
 - **CRUISEC** Basic cruise control with controls in steering wheel
 - **ESP-BAS1** Electronic Stability Program package intended for RIGID single vehicles or vehicle combinations with standard centre of gravity height when laden and for TRACTOR vehicle combinations with a single trailer or multiple trailers with ABS/EBS.
 - **ESPC-RO** ESP (Electronic Stability Program) functionality control - Reduced / Off
- **Standard Equipment**
 - **Optional Equipment**
- **HWSS-AC** Adaptive cruise control with forward collision warning
 - **HWSS-ACB** Adaptive cruise control with forward collision warning (stationary and moving objects) and emergency braking. Using both radar and camera to collect info.
 - **HWSS-FCB** Forward collision warning (stationary and moving objects) with emergency braking
 - **LSS-DW** Lane keeping support - lane departure warning system
 - **LCS** Lane Change Support
 - **DAS-W** Driver Alert Support (drowsy driver warning)
 - **RSENS-W** Wiper rain sensor
 - **CU-ECC** Fully electrically controlled air conditioning with sun sensor
 - **CU-ECC2** Fully electrically controlled air conditioning with sun sensor, mist sensor, air quality sensor and carbon filter
 - **CU-MCC** Electrical manually controlled air conditioning
 - **IMMOBIL** Immobiliser
 - **ALARM-B** Burglar alarm - cab
 - **ALARM-E** Burglar alarm - cab/body/trailer
 - **ALCOLOCK** Alcolock
 - **BUPMON** Back-up monitor including a 7 inch colour display integrated in dashboard, Waeco CCD-camera (delivered loose in cab) with a heated lens, motorised lens protection, 1 m pigtail cable (front) and 10 metres chassis cable for tractor /20 metres for rigid. Camera wirings not installed. Use PCA30081 for installation.
 - **PHONE-PK** Telephone preparation kit (antenna, antenna attachment, cable from antenna to radio shelf).
 - **WLIFT-AD** Electrical window lift, auto up/down driver side; el operated on passenger side
 - **WLIFT-EB** Electrical window lift. From the driver side both windows can be operated and from the passenger side the passenger side window can be operated.
 - **ISUNS-BS** Manually manoeuvred side interior sun visor (roller blind type) on both sides
 - **ISUNS-DS** Manually manoeuvred side interior sun visor (roller blind type) on driver side
 - **ISUNF-B** Interior front plastic sun visors (driver and passenger side) without mirror on driver side
 - **ISUNF-MD** Interior front plastic sun visors (driver and passenger side) with mirror on driver side
 - **ISUNF-RE** Electrical textile interior sun visor (roller blind) integrated in front shelf
 - **ISUNF-RM** Manual interior textile sun visor (roller-blind) integrated in front shelf
 - **CSPU-S** One open storage (behind push open lid) in upper part of dash panel center section
 - **ADFS** Two extra DIN slots in front shelf (push/pull storage), 165x40x180 mm (WxHxD)
 - **BUPALARM** Back-up alarm
 - **RTOLL-PK** Preparation kit for road toll collect (GPS/GSM antenna and cables)
 - **LOADIND** Load indicator with dashboard display. Measures axle pressures, load weight and total weight of truck and one trailer.
 - **REMC-MF** Wireless remote control - multi functional
 - **FIREXT2G** Fire extinguisher 2 kg, German decal
 - **FIREXT3S** Fire extinguisher 3 kg, Swedish/English decal
 - **WARNVEST** Warning vest. Fulfils European standard according to EN 471 class 2.
 - **WARNTRI2** Two warning triangles
 - **AIDKIT** First aid kit containing sticking plaster, washing and drying

For more detailed information about cab and powertrain equipment, please refer to separate specification sheets.

For all possible options and combinations of options please consult your Volvo sales contact who can create a specification to match your requirements using the Volvo Sales Support system (VSS).

The factory reserves the right to modify design and change equipment without previous notification. The specification can vary from country to country.

MODEL RANGE

FMX D13 84 Rigid X-high tag tridem rear air FM 84 TR3CAX

<input type="checkbox"/>	AIDKIT1B	First aid kit containing sticking plaster, compresses, elastic bandages, gloves, scissors, triangular bandage, bandaging cloths, adhesive tape and rescue sheet (German requirements)	<input type="checkbox"/>	TBK60F	Fixed top bunk 600x1900 mm, foldable up to 52 degrees to rear wall (depending on cab version and upper storage). Safety net included.
<input type="checkbox"/>	WARNLAMP	Portable warning lamp with batteries	<input type="checkbox"/>	TBK70F	Fixed top bunk 700x1900 mm, foldable up to 52 degrees to rear wall (depending on cab version and upper storage). Safety net included.
<input type="checkbox"/>	LAMP-IN	Inspection lamp with 10 m cable	<input type="checkbox"/>	PH-CAB2	Cab parking heater, 2 kW
<input type="checkbox"/>	BULBKIT	Bulb and fuse kit	<input type="checkbox"/>	PH-ENGCA	Engine and cab parking heater
<input type="checkbox"/>	WRITEPAD	Writing pad with spring-loaded paper clip	<input type="checkbox"/>	PH-SS	Short stop heater
Cab Interior, Living			<input type="checkbox"/>	SLCP-BAS	Basic sleeper control panel (controlling interior light, parking heater, roof hatch and door lock)
<input type="checkbox"/>	UPHTRI10	Seat upholstery with black embossed textile insert, black vinyl bolster and blue vinyl side insert & textile interior trim in matching grey/blue nuances	<input type="checkbox"/>	SAFE	Key operated safe box under bed (FH) or at bed end (FM)
<input checked="" type="checkbox"/>	UPHTRI11	Seat upholstery with light grey embossed textile insert, raven metallic vinyl bolster and red vinyl side insert & vinyl/textile interior trim in matching skylark/grey/black nuances	<input type="checkbox"/>	ETSB-F	Storage on engine tunnel - on front top
<input type="checkbox"/>	UPHTRI12	Seat upholstery with blue soft textile insert, black vinyl bolster & textile interior trim in matching grey/black/blue colours	<input type="checkbox"/>	ETSB-FR	Storage on engine tunnel - on front top and at rear cab wall
<input type="checkbox"/>	UPHTRI13	Seat upholstery with dark grey leather insert and black leather bolster & vinyl/textile interior trim in matching grey/black nuances	<input type="checkbox"/>	ETSB-FRS	Storage on engine tunnel - on front top & at rear cab wall & storage immersed into tunnel on RH side
<input type="checkbox"/>	UPHTRI14	Seat with dark grey leather insert and black leather bolster & textile interior trim in matching grey and black colours	<input type="checkbox"/>	ETSB-FS	Storage on engine tunnel - on front top and storage immersed into tunnel on right hand side
<input checked="" type="checkbox"/>	DST-CF1	Driver seat, comfort, suspended	<input type="checkbox"/>	ETSB-R	Fixed engine tunnel storage box at rear cab wall
<input type="checkbox"/>	DST-CF4	Driver seat, comfort, suspended, belt in seat	<input type="checkbox"/>	ETSB-RS	Storage on engine tunnel - at rear cab wall and storage immersed into tunnel on right hand side
<input type="checkbox"/>	DST-CF5	Driver seat, comfort, suspended, belt in seat, electrically heated	<input type="checkbox"/>	ETSB-S	Storage on engine tunnel - immersed into tunnel on right hand side
<input type="checkbox"/>	DST-CF6	Driver seat, comfort, suspended, belt in seat, electrically heated, ventilated	<input type="checkbox"/>	RUS-BAS	Rear cab upper storage 154 litres (300 mm high)
<input type="checkbox"/>	SBD-RED	Red safety belts, passenger and driver seats	<input type="checkbox"/>	RUS-HIG	Rear cab upper storage 245 litres (440 mm high)
<input type="checkbox"/>	SBPRE-DS	Driver seat belt pretensioner	<input type="checkbox"/>	TABLE	Foldable and height adjustable table to be mounted to the lower bunk
<input type="checkbox"/>	PST-BAS1	Passenger seat, basic, non suspended	<input type="checkbox"/>	REF-ICPK	Refrigerator preparation kit, engine tunnel mounted
<input type="checkbox"/>	PST-BENC	Bench passenger seat	<input type="checkbox"/>	REFR-RUS	28 litre rear upper wall mounted refrigerator with dividers
<input type="checkbox"/>	PST-CF4	Passenger seat, comfort, suspended, belt in seat	<input type="checkbox"/>	MICRO-PK	Preparation kit for microwave oven (el. cables to front shelf)
<input type="checkbox"/>	PST-CF5	Passenger seat, comfort, suspended, belt in seat, electrically heated	<input type="checkbox"/>	BOTH-D	One 1.5 litre plastic soft-drink bottle holder under dashboard centre section
<input checked="" type="checkbox"/>	PST-STD2	Passenger seat, regular, non suspended	<input type="checkbox"/>	COFMA-PK	Preparation kit (24V) for coffee maker
<input type="checkbox"/>	PST-STD4	Passenger seat, regular, suspended	<input checked="" type="checkbox"/>	INLI-BAS	Interior white light with smooth light transition at on/off, no dimming
<input type="checkbox"/>	SBPRE-PS	Passenger seat belt pretensioner	<input type="checkbox"/>	INLI-NL	Interior white and red (night) light with smooth light transition at on/off
<input type="checkbox"/>	ARM-DBPS	Two armrests on driver seat and one (outer) on passenger seat	<input type="checkbox"/>	INLI-NLD	Interior white and red (night) light with smooth light transition at on/off and dimmer
<input type="checkbox"/>	ARMRE-BB	Two armrests on both driver and passenger seats	<input type="checkbox"/>	ARL-FLEX	Two (driver and passenger side) reading lamps with flexible arms (snake lamps) and led lamps fitted on side walls
<input type="checkbox"/>	ARMRE-DB	Two armrests on driver seat	<input type="checkbox"/>	RH-EE	Without roof hatch, sky window / emergency exit (tinted glass)
<input type="checkbox"/>	ARMRE-PB	Two armrests on passenger seat	<input type="checkbox"/>	RH-ETR	Roof hatch - Electrically operated / Tinted glass / Rear opening
<input type="checkbox"/>	ARMRE-PS	Single armrest (next to driver) on passenger seat	<input type="checkbox"/>	RH-MSR	Roof hatch - Manually operated / Steel / Rear opening
<input type="checkbox"/>	ARU-BAS	Vinyl armrest upholstery	<input type="checkbox"/>	RH-MTR	Roof hatch - Manually operated / Tinted glass / Rear opening
<input type="checkbox"/>	ARU-LEA	Leather armrest upholstery	<input checked="" type="checkbox"/>	URH	Without roof hatch
<input checked="" type="checkbox"/>	FMAT-RU2	Two black rubber floor mats with raised edges and an extended side (FMX)	<input type="checkbox"/>	SWIND-BS	Extra side window on both sides
<input type="checkbox"/>	FMAT-RUB	Two black rubber floor mats	<input type="checkbox"/>	SWIND-PS	Rear side window on passenger side
<input type="checkbox"/>	FMAT-T2E	Two dark grey textile floor mats and two black rubber floor mats with an extended side (FMX)	<input type="checkbox"/>	VANMIR	Vanity mirror in front shelf lid. In sleeper cab on passenger side and in high/extra high cabs in middle section of the front shelf.
<input type="checkbox"/>	FMAT-TX2	Two textile (dark grey on FH/FM, black on FH16) and two black rubber floor mats	<input type="checkbox"/>	AS-FUS	One extra shelf in each of the two front upper storage compartments. Only 1 shelf if microwave oven mounted in one of the two compartments.
<input type="checkbox"/>	LBK-RES	Lower fixed rest kit, foldable to rear wall	<input type="checkbox"/>	INFOT-PK	Preparation kit (bracket, security straps, power cable, antenna cable and aux cable) for mounting of a television above driver door.
<input type="checkbox"/>	LBK70	Lower fixed bunk, not foldable - 2000x700 mm. Safety net included.	Cab Exterior		
<input checked="" type="checkbox"/>	ULBK	Without lower bunk	<input checked="" type="checkbox"/>	PAICS-B	Basic painting in a lightning grey colour of cab surrounding parts (mirror housings, insteps, bumper and if fitted bumper spoiler and sun visor). If fitted roof air deflector, side air deflector and chassis fairings are always painted in cab colour.
<input type="checkbox"/>	MATL-FI	Mattress lower bunk - firm for over approx. 100 kg, pocket springs.			
<input type="checkbox"/>	MATL-SF	Mattress lower bunk - semi-firm up to approx 100 kg, pocket springs.			
<input type="checkbox"/>	OLMAT-BA	Overlay mattress protector, 28 mm thick black textile			
<input type="checkbox"/>	OLMAT-PR	Overlay mattress protector, 35 mm thick black textile			

Standard Equipment

Optional Equipment

For more detailed information about cab and powertrain equipment, please refer to separate specification sheets.

For all possible options and combinations of options please consult your Volvo sales contact who can create a specification to match your requirements using the Volvo Sales Support system (VSS).

The factory reserves the right to modify design and change equipment without previous notification. The specification can vary from country to country.

MODEL RANGE

FMX D13 84 Rigid X-high tag tridem rear air FM 84 TR3CAX

■ GLAS-TIN	Tinted windows (front/side/rear)		
□ AWIND-RF	Rear fixed window (without curtains)		
□ DGLAS-L	Laminated door glass		
■ LOCK-MAN	Manual door locking		
□ LOCK-MRP	Manual door locking with internal remote control (from driver side) of passenger door		
□ LOCK-REM	Central door locking with remote control		
■ BUMP-HD	Heavy duty front bumper		
□ AUXFS	Extra cab side foot-step		
□ GUARD-EH	Guard plate for cooling pipes and oil sump		
□ SIDEH-B	Guide rail on day cab driver side		
□ SIDSTP-R	Side ladder and guide rail on on day cab driver side		
■ BUGNET	Radiator screen / Mosquito net (PVC coated fibreglass) in front of radiator		
□ CTILT-P-E	Electrical cab tilt pump		
■ CTILT-P-M	Manual cab tilt pump		
□ FCABS-A	Air front cab suspension		
■ FCABS-M	Mechanical cab suspension		
□ RCABS-A	Air rear cab suspension		
■ RCABS-M	Mechanical rear cab suspension		
□ MIRCOMFX	El heated & operared robust main rear view mirrors, electrically heated wide angle mirrors (both sides). Close view mirror on passenger side.		
■ MIRSTDX	Electrically heated robust main rear view mirrors and wide angle mirrors (both sides). Close view mirror on passenger side.		
■ AMIR-F20	Front close view mirror above windscreen, passenger side (radius 200 mm)		
□ SUNV-H	Exterior transparent dark grey front sun visor		
□ AD-ROOF	Roof air deflector. Design (length, height etc.) automatically calculated and varies depending on vehicle total height (chassis height, cab type, tyres etc).		
□ AD-SIDEL	Long cab side air deflector		
□ AD-SIDES	Short cab side air deflectors		
■ HL-BAS2	Halogen H1 head lamps (heavy duty)		
□ HL-BASIC	Halogen H7 head lamps		
□ HL-BHID2	Bi-Xenon head lamps, high intensity discharged (heavy duty)		
□ HL-CLEAN	High pressure headlamp cleaner		
□ HLP-ST	Steel headlamp protection		
□ HL-ADJ	Adjustable headlamps to adjust the height of the light beam		
■ DRL-LED	V-shaped ("V-light") day running light (LED). Turned on low beam gives a dimmed "V-light".		
■ UDRIVL	Without auxiliary front driving lamps		
□ ASL-RF2	Two Hella H11 70W spot lamps in sign box (one on each side of the Globetrotter sign)		
□ ASL-RFPK	Preparation kit for two spot lamps in sign box		
□ BEACO2F	Two front roof mounted amber rotating beacon warning lamps. Mounted on accessory bracket if ordered, otherwise on cab roof on both sides of the hatch.		
□ BEACO2R	Two rear roof mounted (on accessory bracket) amber warning lamps. Rotating beacon lamps mounted on sleeper cab. Flashing LED lamps mounted on high/extra high sleeper cabs.		
□ BEACON-P	Prepared wiring (switch and connected relay included) for warning lamps on cab roof. Max load 300 W.		
□ BEACONA4	Four roof mounted amber warning lamps. 2 front mounted (on accessory bracket if ordered) rotating beacon lamps. 2 rear mounted (on mandatory accessory bracket) rotating beacon lamps on sleeper cab.		
		2 rear mounted (on mandatory accessory bracket) flashing LED lamps on high/xhigh sleeper cabs.	
		□ CABPT-R1	One front cab roof pass through on passenger side
		■ CABPT-R2	Two front cab roof pass throughs, one on each side
		□ SPOTP-F	Spotlamp preparation in cab front, max 280W
		□ SPOTP-R	Spotlamp preparation on cab roof, max 280W
		□ SPOTP-RF	Spotlamp preparation on cab roof and in cab front, max 2x280W
		□ ROS-IL	Illuminated roof sign with switch in radio shelf. Switch for turning on/off.
		□ ROS-IL2	Preparation kit for installing an illuminated roof sign*. It includes a prerouted cable harness, a switch and LED-lamps. The switch is connected in the radio shelf middle section. Switch cap with icon, are enclosed in cab. Lamps in sign are mounted. The stripe in the Globetrotter window is selected via the cab sign variants
		□ ROS-ILP	Wiring preparation kit (wires and switch) for cab sign or roof air deflector illumination
		□ CSGN-FMX	FMX decal in the cab roof sign area
		■ HORN-F1S	One front mounted (behind grille) single tone air horn, Jericho. Operated by steering wheel buttons.
		□ HORN-R2S	Two roof mounted single tone chromed air horns. Operated by steering wheel buttons.
		□ ANT-CBR	Right hand side roof mounted foldable antenna and cables for CB radio, single aerial.
		□ ACCBR-AP	Front, middle & rear roof mounted accessory brackets
		□ ACCBR-F	Front roof mounted accessory bracket
		□ ACCBR-FM	Front & middle roof mounted accessory brackets
		□ ACCBR-FR	Front & rear roof mounted accessory brackets
		□ ACCBR-M	Middle roof mounted accessory bracket
		□ ACCBR-R	Rear roof mounted accessory bracket
		□ ACCBR-RM	Rear & middle roof mounted accessory brackets
		□ REFS-TW	Reflecting white cab side stripes by-packed in cab
		□ REFS-TY	Reflecting yellow cab side stripes by-packed in cab
		Superstructure preparations	
		□ SRWL-PK	Wiring preparation for chassis mounted working lamps and a 3-position switch (On/Off/Reverse auto on). Max load 280W.
		□ SWL-2FW	Two H3 70W white front chassis mounted (LH/RH side) working lamps and a 2-position switch (On/Off)
		□ SWL-2RW	Two H3 70W white rear chassis mounted (LH/RH side) working lamps and a 2-position switch (On/Off)
		□ SWL-4W	Four H3 70W white front (2) and rear (2) chassis mounted (LH/RH side) working lamps and a 2-position switch (On/Off)
		□ SWL-PK	Wiring preparation for chassis mounted working lamps and a 2-position switch (On/Off). Max load 280W.
		□ WL-CHPK	Preparation kit (switch and cable) for working lamp, max 2x70 W. Connector on chassis at gearbox.
		□ WLC-H2A	Two H3/70W working lamps with amber coloured lens high mounted back of cab (switch incl).
		□ WLC-H2W	Two H3/70W working lamps, white lens high mounted back of cab (switch incl).
		□ WLC-PKCH	Preparation kit (cables and switch) for cab mounted chassis working lamp. Max load 280W.
		□ WLC-PKH	Preparation kit (cables and switch) for high mounted working lamps back of cab (pass through in cab rear roof included). Max load 280W.
		□ WLC-PKL	Preparation kit (cables and switch) for low mounted working lamps back of cab (pass through in cab rear wall included). Max load 280W.
		□ WLC-PKLH	Preparation kit (cables and switch) for low and high mounted working lamps back of cab (pass throughs in rear wall and rear roof included). Max load 280W.
		□ ECBB-BAS	Body builder electrical centre without any body builder module
		■ ECBB-HIG	Body builder electrical centre with cab body builder module
		□ BBCHAS1	One 7-pole connector for Body builder interface. Wiring harness routed from the bodybuilder electrical distribution box inside the cab to a connection point inside the
■ Standard Equipment	□ Optional Equipment		

For more detailed information about cab and powertrain equipment, please refer to separate specification sheets.

For all possible options and combinations of options please consult your Volvo sales contact who can create a specification to match your requirements using the Volvo Sales Support system (VSS).

The factory reserves the right to modify design and change equipment without previous notification. The specification can vary from country to country.

MODEL RANGE

FMX D13 84 Rigid X-high tag tridem rear air FM 84 TR3CAX

- **BBCHAS3** right frame rail beside the gearbox.
Three 7-pole connectors for Body builder interface.
Wiring harness routed from the bodybuilder electrical distribution box inside the cab to a connection point inside the right frame rail beside the gearbox.
- **BEPR-T2** Body builder electrical software preparation for tipper with remote control
- **EXSTER** Support for external steering control via body builder module
- **TD-BAS** Trailer detection without LED sensor
- **TD-LED** Trailer detection with LED sensor
- **FRFS-BS** Frame rail free space on both sides to give space for crane legs or other equipment.
One front axle with day cab: 515/507 mm (L/R side).
One front axle with long cab: 288/360 mm (L/R side).
Two front axles with short cab: 632/572 mm (L/R side).
Two front axles with long cab: 405/485 mm (L/R side).
- **FBA-BTF** Lower front body attachments for torsionally flexible platform body
- **FBA-BTSF** Lower front body attachments for torsionally semi-flexible body (van or curtainsider)
- **HBA-FSFB** Holes for body attachments, flexible/semi-flexible body
- **HBA-SB** Holes for body attachments, stiff body
- **RBA-T2** Lower rear body attachments for helper frame
- **CRANEPK1** Crane plates mounted to frame, interface for crane capacity up to 10 ton meter
- **CRANEPK2** Crane plates mounted to frame, interface for crane capacity up to 20 ton meter
- **CRANEPK4** Crane plates mounted to frame, interface for crane capacity up to 40 ton meter
- **AUXL-SPK** Electrical preparation kit (wiring and a switch in dashboard) for snow plough lights.
Preparation for installation of additional headlights and additional turning indicators.
- **TAILPRE2** Tail lift preparation kit, wireless remote operation
- **TAILPREP** Tail lift preparation kit, wire remote operation
- **AESW2** Two Body builder bistable electrical switches (marked AUX1 / AUX2)
- **AESW2PK** Two Body builder bistable electrical switches (marked AUX1/AUX2) and in an empty 4-group preparation another four bistable switches with dummy switch caps
- **AUXSW-4** Wiring for 4 extra hardwired switches (from Body builder electrical centre to switch positions)

Services

- **TGW-4GWL** Telematics gateway with 4G modem
- **FMS-PK** Fleet Management System gateway, preparation kit
- **DRUT** My truck app gives the driver instant status information and control of the vehicle remotely from a smartphone or tablet.
The variant enables the My truck app to connect to the vehicle.

VOLVO

Volvo Truck Corporation

volvotrucks.com