

MODEL RANGE

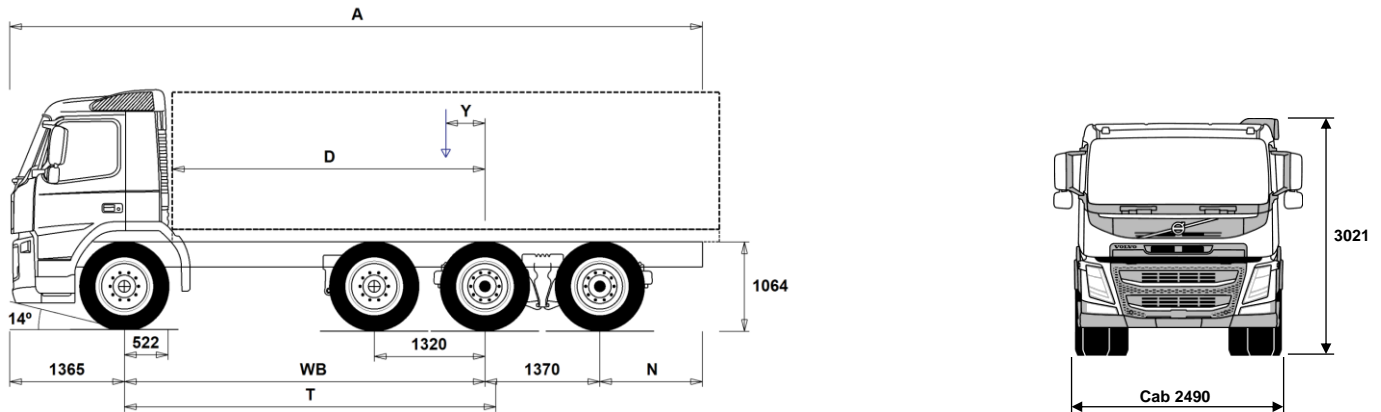

Volvo Trucks. Driving Progress

FM 13 8x4 Rigid - Pusher Axle Tridem – contact sales engineering reference application



Chassis Dimensions [mm]

| WB Wheelbase | 4300 | 4600 | 4900 | 5100 | 5300 | 5600 |
|--|------|------|-------|-------|-------|-------|
| A Overall Chassis Length | 9410 | 9860 | 10310 | 10660 | 10910 | 11410 |
| D Center of rear axle to front of body | 3728 | 4028 | 4328 | 4528 | 4728 | 5028 |
| N Rear Overhang (Min.) | 1225 | 1225 | 1225 | 1225 | 1225 | 1225 |
| N Rear Overhang (Max.) | 2375 | 2525 | 2675 | 2825 | 2875 | 3075 |
| T Theoretical Wheelbase | 4428 | 4728 | 5028 | 5228 | 5428 | 5728 |
| Y Center of Gravity for Payload (Min.) | -263 | -265 | -266 | -279 | -284 | -292 |
| Y Center of Gravity for Payload (Max.) | 574 | 629 | 686 | 716 | 751 | 803 |

Chassis Weights [kg]

| | | | | | | |
|--|-------|-------|-------|-------|-------|-------|
| Front Axle | 4935 | 4905 | 4875 | 4905 | 4895 | 4895 |
| Rear Bogie | 4095 | 4150 | 4200 | 4275 | 4300 | 4365 |
| Kerb Weight | 9030 | 9055 | 9075 | 9180 | 9195 | 9260 |
| Payload (including body, driver, fuel, etc.) | 19320 | 19295 | 19275 | 19170 | 19155 | 19090 |

Turning Diameter [mm]

| | | | | | | |
|--------------------------------------|-------|-------|-------|-------|-------|-------|
| Turning Circle Diameter Kerb to Kerb | 17300 | 18200 | 19100 | 19700 | 20300 | 21300 |
| Turning Circle Diameter Wall to Wall | 18700 | 19700 | 20600 | 21200 | 21800 | 22700 |

Plated Weights [kg]

| | Plated | Design |
|--------------------------|--------|--------|
| Gross Vehicle Weight | 28350 | 36000 |
| Gross Combination Weight | 44000 | 44000 |
| Front Axle | 8000 | 9000 |
| Rear Bogie | 24000 | 27000 |

Important Notes

Chassis Dimensions

Cab Height: +416 mm for CAB-HSLP, -169 mm for CAB-LSLP, +554 mm for CAB-XHSL.

Front Axle to Back of Cab: +424 mm for CAB-HSLP and CAB-SLP and CAB-XHSL, +418 mm for CAB-LSLP.

D-measure includes a front clearance of 50 mm and for rigid trucks also a subframe of 100 mm.

Height can vary ± 20 mm for leaf and ± 10 mm for air suspension.

All dimensions are for unladen chassis and any tag axles down. Chassis height used: CHH-HIGH.

Rear overhang used for vehicle weight calculation is the maximum rear overhang (N Max.) for selected wheelbase.

Height change when chassis height CHH-MED,FRAME300: 0 mm.

Weight and dimensions are based upon the following tyres:

| | |
|-----------------------------|-------------|
| Front Axle Tyres: | 315/80R22.5 |
| Drive Axle Tyres: | 315/80R22.5 |
| Trailing/Pusher Axle Tyres: | 315/80R22.5 |

Chassis weight includes oil, water, AdBlue, 0 litres fuel and without driver. Kerb weight can vary $\pm 3\%$.

Turning diameters are theoretically calculated. Tag axle used: PA-HYDRS.

Legal weights can differ from country to country.

For more detailed weight information, including optional equipment weights, ask your Volvo sales contact to enter your specification into the Volvo Weight Information system (WIS).

Do NOT use this drawing for bodybuilding. Refer to Volvo Bodybuilder Instructions and chassis assembly drawing FM84PR3HA.

MODEL RANGE

FM 13 8x4 Rigid - Pusher Axle Tridem – contact sales engineering reference application

TRUCK USE

- RC-ROUGH** Operating class on/off road
- RC-SMOOT** Operating class highway
- GARB-PRE** Garbage preparation
- TIPP-PRE** Tipper vehicle preparation
- UNIFORM** Basic platform vehicle

CORE COMPONENTS

- CHH-HIGH** Chassis height high - N3 "On Road" chassis - For a specific loading height always check the unique BEP chassis drawing
- CHH-MED** Chassis height medium - For a specific loading height always check the unique BEP chassis drawing
- PU-EHYS** Electro-hydraulically steered pusher axle
- RAPDD-GR** Rear air suspension, 3 axles - 1 pusher/2 driven
- FM-DAY** Day cab - with steel safety cage design
Designed and built to Swedish impact and ECE R29 regulations
- FM-HSLP** Globetrotter cab - with steel safety cage design
Designed and built to Swedish impact and ECE R29 regulations
- FM-LSLP** Low sleeper cab - with steel safety cage design
Designed and built to Swedish impact and ECE R29 regulations
- FM-SLP** Sleeper cab - with steel safety cage design
Designed and built to Swedish impact and ECE R29 regulations
- FM-XHSL** Globetrotter LXL cab - with steel safety cage design
Designed and built to Swedish impact and ECE R29 regulations
- EU6SCR** Emission level - Euro 6
- D13 420S** D13K420 12.8 litre engine developing 420hp at 14-1800rpm.
Peak torque 2100Nm at 860 -1400rpm.
- D13 460S** D13K460 12.8 litre engine developing 460hp at 14-1800rpm.
Peak torque 2300Nm at 900-1400rpm.
- D13 500S** D13K500 12.8l engine developing 500hp at 14-1800rpm.
Peak torque 2500Nm at 1000-1400rpm.
- D13K420** D13K420 - 420hp engine
- D13K460** D13K460 - 460hp engine
- D13K500** D13K500 - 500hp engine
- EBR-EPG** Exhaust brake controlled by steering column switch
- EBR-EPGC** Exhaust pressure governor for I shift gearbox
- EBR-VEB+** Volvo engine brake + and exhaust pressure governor, enhanced performance from additional exhaust rocker control.
Retardation 375kW
- AT2612F** AT2612F 12-speed "I-shift" automated mechanical gearbox suitable for gross train weights up to 60tonne only refer to sales engineering when used in conjunction with a PTO
- ATO2612F** ATO2612F 12-speed "I-shift" overdrive automated mechanical gearbox suitable for gross train weights up to 60tonne refer to sales engineering when used in conjunction with a PTO
- PT2606** Powertronic automatic 6-speed gearbox, max. engine torque 2600 Nm, max. permitted GCW 130000 kg
- SPO2812** SPO2812 - 12 speed I-shift Dual Clutch automated mechanical gearbox GCW 60tonne
- RTH2610F** RTH2610F hub reduction tandem 26tonne drive axles, GCW 100 tonnes with differential and cross locks*
* Cross locks replaced by a dog clutch if tandem axle lift is specified
- RTS2310A** RTS2310A single reduction tandem 23tonne drive axles with differential and cross locks* - design GCW 100tonnes.
* Cross locks replaced by a dog clutch if tandem axle lift is specified.
- RTS2370A** RTS2370A single reduction tandem 23tonne drive axles with differential and cross locks* - design GCW 70tonnes.
* Cross locks replaced by a dog clutch if tandem axle lift is specified.

Standard Equipment

Optional Equipment

For more detailed information about cab and powertrain equipment, please refer to separate specification sheets.

For all possible options and combinations of options please consult your Volvo sales contact who can create a specification to match your requirements using the Volvo Sales Support system (VSS).

The factory reserves the right to modify design and change equipment without previous notification. The specification can vary from country to country.

PACKAGES

- LHFP-VE** Long Haul Fuel Economy driving package
- LHFP-VE+** Long Haul Fuel Economy plus driving package
- DRIVEFM** Cab Package: Drive
- DRIVEFM+** Cab Package: Drive +
- BEDFM** One bed resting package
- AUDHIG** High Power Audio system: RDS radio with CD player - also playing MP3/WMA files from CD -, with integrated bluetooth phone and USB/Line inputs. FM/AM antenna, speakers in dashboard, doors, and sleeping compartment.
- MEDIA** AM/FM Bluetooth radio without CD player.
USB and Aux line inputs.
Speakers in dashboard, doors, and sleeping compartment.
7" touch screen with personal apps.
- MEDIADF** AM/FM Bluetooth radio without CD player.
USB and Aux line inputs.
Speakers in dashboard, doors, and sleeping compartment.
7" touch screen with personal and professional apps.
Dynafleet vehicle on-board data display with office internet support.
- MEDIANAV** AM/FM Bluetooth radio without CD player.
USB and Aux line inputs.
Speakers in dashboard, doors, and sleeping compartment.
7" touch screen with personal and professional apps.
Truck based satellite navigation (live updates not included)
- MEDIANDF** AM/FM Bluetooth radio without CD player.
USB and Aux line inputs.
Speakers in dashboard, doors, and sleeping compartment.
7" touch screen with personal and professional apps.
Truck based satellite navigation (live updates not included)
Dynafleet vehicle on-board data display with office internet support.
- VISI15** Visibility Package
- VISI15+** Visibility Plus Package
- RCHAPAC1** Chassis Package Rigid

CHASSIS

- FST-AIR** Front suspension type - air
- FST-PAR** Front suspension type - 2 leaf parabolic springs
- FST-PAR3** Front suspension type - 3 leaf parabolic springs
- FSL5-BAS** Front suspension levelling - basic stroke
- FSL5-HI** Front suspension levelling - high stroke for demount operations - check with bodybuilder
- FAL10.0** Front axle design capacity 10 tonnes - Ensure that you have checked the tyre load index
- FAL9.0** Front axle design capacity 9.0 tonnes - Ensure that you have checked the tyre load index
- FSM-LUB** Lubricated rear shackles on front suspension pins and bushings
- FSTAB** Front anti-roll bar
- FSTAB2** Front anti-roll bar medium stiffness
- FSTAB3** Front stiff anti-roll bar
- RAL27** Rear bogie design capacity 27 tonnes
- RAL30.5** Rear bogie design capacity 30.5 tonnes
- RAL32** Rear bogie design capacity 32 tonnes
- RAL35** Rear bogie design capacity 35 tonnes
- RSTAB3** Rear stiff anti-roll bar
- RALIM105** Rear axle load limiter, 10.5 tonnes
- RALIM115** Rear axle load limiter, 11.5 tonnes
- RALIM13** Rear axle load limiter, 13 tonnes
- RALIM95** Rear axle load limiter, 9.5 tonnes
- ACTST-TO** Volvo Dynamic Steering (VDS) with with extra electronic pump and torque overlay
- ASFE-BAS** Active steering feature - Basic - Volvo Dynamic Steering only
- ASFE-PS** Active steering feature - Volvo Dynamic Steering with personal settings

MODEL RANGE

FM 13 8x4 Rigid - Pusher Axle Tridem – contact sales engineering reference application

| | | | |
|-------------------|---|-------------------|---|
| ■ PSS-DUAL | Dual power steering system | | |
| □ PSS-SING | Single power steering system | | locker |
| ■ PSP-VAR | Power steering pump with variable displacement | □ TB-R80 | Toolbox 800 mm, right side |
| ■ EBS-MED | EBS medium package including "hill" hold function | □ SUP-BAS | EC approved chassis side guards |
| □ AUXPARK | Additional spring parking brakes | □ CHAIN-S | Snow chains |
| ■ FBREG-E | Front regulating brake valve, EBS | □ HOOK-SC | Snow chain hooks |
| ■ SUSPL-EC | Remote electronic control on wander-lead for air suspension levelling | ■ TOWF-NO1 | One front towing device |
| | | □ TOWF-NO2 | Two front towing devices |
| ■ FRAME300 | Frame rail section external height 300 mm | □ TOWMBRH | Towing member, high mounted in centre of frame, D = 190 |
| ■ FST7070 | Frame thickness - web and flange 7.0mm | □ TOWMBRL1 | Towing member, low mounted under the frame |
| ■ FST8080 | Frame thickness - web and flange 8.0mm | □ TOWMBRM | Towing member, medium mounted in line with frame lower flange |
| □ FIL-EEEB | Inner liner from end of engine to end of bogie | ■ RFEC-S | Rear frame end, straight cut for regular platform applications |
| □ FIL-EEEF | Inner liner from end of engine to end of frame | □ RFEC-U | Rear frame end, upper cut for tipper applications. |
| ■ FIL-TXEB | Inner liner from gearbox member to end of bogie | □ C-RI4040 | Towing coupling, Ringfeder 4040 G-150 |
| □ FIL-TXEF | Inner liner from gearbox member to end of frame | □ C-RI5055 | Towing coupling, Ringfeder 5055 G-150 |
| ■ BBOX-L | Battery box located on left hand side | □ C-RO400G | Towing coupling, Rockinger 400 G-150 for 40mm eyes |
| □ BATS-D | Dual energy battery system - 2 living batteries and 2 starter batteries. | □ C-RO50 | Rockinger RO 50 50mm for centre axle trailer |
| ■ BATS-S | Single energy battery system (2 batteries) | □ TOWR-ONE | Towing hitch attached to rear crossmember |
| □ 2BAT210B | 2 x 210 Ah capacity Gel batteries | ■ TREL-PK | Trailer electrical preparation kit - chassis/cab wiring |
| ■ 2BATT170 | 2 x 170 Ah capacity batteries | □ TREL14 | Single 14 pole electrical trailer connector |
| □ 2BATT225 | 2 x 225 Ah capacity batteries | □ TREL15 | Single 15 pole electrical trailer connector - ADR certified |
| ■ BATTAMP | Battery voltage and ampere gauge | □ TREL7 | 7 pole - 24N trailer electrical suzie |
| □ BATTIND | Battery charge indication | □ TREL7-7 | 24N and 24S trailer electrical suzies |
| □ ADR2 | ADR package for transportation of dangerous goods on road (Note does NOT include safe loading pass package if required this is quoted seperately) | □ TBC-DUO | Duomatic type air line connectors |
| □ MSWI-A | Main switch - ADR switch circuit shut down | □ TBC-EC | Palm coupling type air line connectors |
| ■ MSWI-C | Main switch - Chassis mounted toggle switch by battery box | □ TRBR-HCF | Full pressure hand controlled trailer brake |
| □ MSWI-R | Main switch - Key fob operated remote controlled | ■ TRBR-STA | Stationary trailer brake control |
| ■ R330A71 | Right aluminium 710 mm D-shaped fuel tank, 330 litres volume Min volume 210l Max volume 810l | □ TRB-STRE | Stretch Brake - Automatic low speed trailer brake activation to avoid jack-knifing and improve steerability |
| ■ UL-FUEL | Without left fuel tank Min volume 160l Max volume 690l | □ RUP-FOSL | Folding & sliding EC approved aluminium rear underrun |
| □ ADTP-L | AdBlue tank on left hand side | □ RFEND-B | Three piece EC approved rear mud wings and spray flaps |
| ■ ADTP-R | AdBlue tank on right hand side | □ RFEND-T | Rear mud wings, transport mounted |
| □ ADB048 | AdBlue tank usable volume 48 litres | □ RFH-BAS | Basic rear wing height |
| ■ ADB064 | AdBlue tank usable volume 64 litres | □ RFH-HIG | High rear wing height - higher wing tops |
| □ ADB068 | AdBlue tank usable volume 68 litres | □ RFH-LOW | Lower rear wing height - shallower wing tops |
| □ ADB090 | AdBlue tank usable volume 90 litres | □ ATANK-AL | Aluminium air tanks |
| □ ADB100 | AdBlue tank usable volume 100 litres | ■ ATANK-ST | Steel air tanks |
| □ ADTC-BF | AdBlue tank cover with satin alloy look decorative cover | ■ TL-LED | Rear lights LED |
| ■ FCAP-L | Locking fuel filler cap | □ BLIGHT-E | Emergency brake light |
| ■ FUFF-AS | Fuel filling anti-spillage device | | |
| □ FUFF-ATS | Fuel filling anti-theft and anti-spillage devices | | |
| □ ESH-LEFT | Horizontal silencer, left exhaust outlet | | |
| ■ ESH-REAR | Horizontal silencer, rear exhaust outlet | | |
| □ ESH-RIGH | Horizontal silencer, right exhaust outlet | | |
| □ ESH-VERT | Horizontal silencer, vertical exhaust outlet | | |
| □ EXST-SSP | Stainless steel exhaust stack - NOT polished | | |
| □ EXST-ST | Steel exhaust stack | | |
| □ HS-NAR | Narrow heat shield | | |
| □ WHC-FIX2 | Two fixed wheel chocks | | |
| □ WHC-FOL2 | Two foldable wheel chocks | | |
| □ WHCP-F | Wheel chock(s) stored in the front part of the vehicle | | |
| □ WHCP-M | Wheel chock(s) stored in the middle part of the vehicle | | |
| □ WHCP-R | Wheel chock(s) stored in the rear part of the vehicle | | |
| □ WHCP-T | Transport mounted wheel chock(s) stored in cab outer luggage | | |

■ Standard Equipment

□ Optional Equipment

For more detailed information about cab and powertrain equipment, please refer to separate specification sheets.

For all possible options and combinations of options please consult your Volvo sales contact who can create a specification to match your requirements using the Volvo Sales Support system (VSS).

The factory reserves the right to modify design and change equipment without previous notification. The specification can vary from country to country.

MODEL RANGE

FM 13 8x4 Rigid - Pusher Axle Tridem – contact sales engineering reference application

- **TOOL-BAS** Basic Toolkit
- **TOOLKIT** Complete tool kit
- **INFLAHOS** Tyre inflation hose
- **GAUGE-TP** Tyre pressure gauge
- DRIVELINE EQUIPMENT**
- **ASO-C** Crawler gear -
Ratio direct top gearbox 19:1
Ratio Overdrive gearbox 17:1
- **ASO-ULC** Ultra low crawler and crawler gear -
Ratios direct top gearbox 32:1 and 19:1
Ratios Overdrive box 32:1 and 17:1
- **TRAP-HD** Reinforced gearbox application
- **TP-CON** Construction Package
- **TP-DIST** Distribution Package
- **TP-HD** I-shift software - Heavy duty for high GCW
Special conditions apply consult Sales Engineering
- **TP-LONG** Long Haul Package
- **AMSO-AUT** Enhanced I-shift software with manual shift available in auto mode and kickdown facility on accelerator pedal
- **AVO-ENH** Enhanced software for off road driveability and starting
- **APF-ENH** I-shift enhanced PTO functions
- **RET-TH** Gearbox mounted retarder
- **RET-TPT** Hydraulic Retarder for Powertronic gearbox
- **TC-HWO** Automatic gearbox oil cooler - water to oil
- **TC-MAOH2** Extra high performance transmission oil cooler - air to oil with front mounted radiator
- **TC-MWO** Basic transmission oil cooler - water to oil
- **2COM1100** Two cylinder, air compressor, 1100 litres per minute
- **2COMP900** Two cylinder, air compressor, 900 litres per minute
- **CLU-AIRC** Clutchable air compressor
- **AIRIN-HI** Roof mounted air intake behind cab on left hand side
- **AIRIN-LO** Low level air intake behind cab on left hand side
- **ACL1ST-S** Two stage air filter
- **24AL110B** 110 amp alternator
- **24AL120B** 120 amp alternator
- **24AL150B** 150 amp alternator
- **CCV-C** Closed crankcase engine ventilation
- **CCV-O** Open crankcase engine breather
- **CCV-OX** Closed crankcase ventilation for cold markets
- **PRIM-EL** Electrical priming pump
- **PRIM-MAN** Manual priming pump
- **AF-R** Hot fuel recirculation heated fuel filter
- **FUEFE2LW** Large engine mounted dual fuel filter with water separator
- **FUEFE2SW** Small engine mounted dual fuel filter with water separator
- **EST-AID** Air inlet manifold starting heater element
- **220EBH15** 220V/1.5Kw electric engine block heater
- **PTER-100** Rear engine mounted power-take-off with DIN 100 / ISO 7646 flange
- **PTER-DIN** Rear engine mounted PTO with DIN5462 (female) splined shaft for a close coupled pump.
Models with 3 steering axles will use this to drive the steering pump (AUXPSP)
- **PTER1400** Rear engine mounted power-take-off with SAE 1410 flange
- **HPE-F101** Parker F1-101, engine mounted, fixed displacement, single flow, engine mounted hydraulic pump
- **HPE-F41** Parker F1-41, engine mounted, fixed displacement, single flow, engine mounted hydraulic pump
- **HPE-F51** Parker F1-51, engine mounted, fixed displacement, single flow, engine mounted hydraulic pump
- **HPE-F61** Parker F1-61, engine mounted, fixed displacement, single flow, engine mounted hydraulic pump
- **HPE-F81** Parker F1-81, engine mounted, fixed displacement, single flow, engine mounted hydraulic pump
- **HPE-T53** Parker F2-53/53, engine mounted, Fixed displacement, Twin flow engine mounted hydraulic pump
- **HPE-T70** Parker F2-70/35, engine mounted, Fixed displacement, Twin flow engine mounted hydraulic pump
- **HPE-V45** Parker VP1-45, variable displacement, single flow, engine mounted hydraulic pump
- **HPE-V75** Parker VP1-75, variable displacement, single flow, engine mounted hydraulic pump
- **PTPT-D** Powertronic PTO, 1 front/upper DIN connection for plug-in pump (max. 850 Nm)
- **PTPT-F** Powertronic PTO, 1 front/upper rear facing SAE flange conn. for prop shaft (max.850 Nm)
- **PTR-D** Gearbox PTO for plug-in pump, 0.71xeng speed
- **PTR-DH** Gearbox driven high speed PTO for one plug-in hydraulic pump
- **PTR-DM** Gearbox driven medium speed PTO for one plug-in hydraulic pump
- **PTR-F** Gearbox driven PTO with rear flange connection
- **PTR-FH** Gearbox driven high speed PTO with SAE drive flange
- **PTR-FL** Gearbox driven low speed PTO with SAE drive flange
- **PTRD-D** Gearbox driven HIGH SPEED PTO for two plug-in hydraulic pumps
- **PTRD-D1** PTRD-D1 Gearbox driven HIGH SPEED PTO (1 SAE flange & 1 plug-in hydraulic pump)
- **PTRD-D2** Gearbox driven HIGH SPEED PTO (2 SAE flanges & 1 plug-in hyd pump)
- **PTRD-F** PTO with 1 DIN + 1 flange connection rear, manual gearbox
- **HPG-F101** Parker F1-101 gearbox mounted, fixed displacement, single flow, hydraulic pump
- **HPG-F41** Parker F1-41 gearbox mounted, fixed displacement, single flow, hydraulic pump
- **HPG-F51** Parker F1-51 gearbox mounted, fixed displacement, single flow, hydraulic pump
- **HPG-F61** Parker F1-61 gearbox mounted, fixed displacement, single flow, hydraulic pump
- **HPG-F81** Parker F1-81 gearbox mounted, fixed displacement, single flow, hydraulic pump
- **EIDLESD** Engine idle shut down
- **DTRI-PER** Dashboard in darker peregrine greyish brown. Steering wheel grey and door panels in light beige for FH and black for FH16.
- **STWPOS-R** RIGHT HAND DRIVE
- **STWM-LE** Leather steering wheel
- **STGW-AD2** Adjustable steering wheel with neck tilt
- **STGW-ADJ** Adjustable steering wheel
- **AIRBAG** SRS Driver's air bag
- **DRC-AMII** DPF Regeneration control switch - for manual and switching off regeneration
- **1DAYDIG2** Continental VDO DTCO 4.0 smart tachograph
This tachograph can ONLY offer remote download if the option of Dynafleet or an FMS gateway has been specified with this order.
- **1DAYDIGP** Continental VDO DTCO 3.0 digital tachograph
For vehicles with long lead time - this includes prep kit for the retrofit of DTCO 4.0 tachograph.
For updating to new legal demand for trick registration from 15th June 2019.
This tachograph can ONLY offer remote download if the option of Dynafleet or an FMS gateway has been specified with this order.
- **ARSL** Additional road speed limit - switch in dashboard
- **CRUIS-E** Eco cruise control (with eco-roll and I-cruise, controls in steering wheel)
- **CRUISEC** Cruise control, standard
- **ESP-BAS1** Electronic Stability Control

■ Standard Equipment

□ Optional Equipment

For more detailed information about cab and powertrain equipment, please refer to separate specification sheets.

For all possible options and combinations of options please consult your Volvo sales contact who can create a specification to match your requirements using the Volvo Sales Support system (VSS).

The factory reserves the right to modify design and change equipment without previous notification. The specification can vary from country to country.

MODEL RANGE

FM 13 8x4 Rigid - Pusher Axle Tridem – contact sales engineering reference application

| | | | |
|---|---|---|---|
| <input type="checkbox"/> ESPC-RO | ESP (Electronic Stability Program) functionality control - Reduced / Off | <input type="checkbox"/> UPHTRI12 | Seats: Blue soft textile insert, black vinyl bolster. Interior trim: Raven black bunk and curtains & blue textile side walls |
| <input type="checkbox"/> HWSS-ACB | Adaptive cruise control ACC with forward collision warning and AEBS advanced emergency brake system | <input type="checkbox"/> UPHTRI13 | Seats: Dark grey leather insert and black leather bolster. Interior trim: Raven black bunk and curtains & grey vinyl side walls |
| <input type="checkbox"/> HWSS-FCB | Forward collision warning with AEBS advanced emergency brake system | <input type="checkbox"/> UPHTRI14 | Seat: Dark grey leather insert and black leather bolster. Interior trim: Raven black bunk and curtains & blue textile side walls |
| <input type="checkbox"/> LSS-DW | Lane departure-warning system | <input checked="" type="checkbox"/> DST-CF4 | Driver seat, comfort, suspended, belt in seat |
| <input type="checkbox"/> LCS | Lane change support | <input type="checkbox"/> DST-CF5 | Driver seat, comfort, suspended, belt in seat, electrically heated |
| <input type="checkbox"/> DAS-W | Driver Alert Support system | <input type="checkbox"/> DST-CF6 | Driver seat, comfort, suspended, belt in seat, electrically heated, ventilated |
| <input type="checkbox"/> RSSENS-W | Rain sensing windscreen wipers | <input type="checkbox"/> SBD-RED | Red seat belts |
| <input type="checkbox"/> CU-ECC | Electrically controlled air conditioning with sun sensor | <input type="checkbox"/> SBPRE-DS | Driver seat belt pretensioner |
| <input type="checkbox"/> CU-ECC2 | Electrically controlled air conditioning with sun sensor, mist sensor, air quality sensor and carbon filter | <input checked="" type="checkbox"/> PST-BAS1 | Passenger seat - Fixed non suspended fold up with seatbelt mounted in cab |
| <input checked="" type="checkbox"/> CU-MCC | Climate unit with manual controlled air conditioning | <input type="checkbox"/> PST-BENC | Bench passenger seat |
| <input checked="" type="checkbox"/> IMMOBIL | Thatcham H2 approved immobiliser | <input type="checkbox"/> PST-CF4 | Passenger seat - Comfort suspended with seatbelt mounted in seat |
| <input type="checkbox"/> ALARM-B | Thatcham H1 approved vehicle alarm - Cab only | <input type="checkbox"/> PST-CF5 | Passenger seat - Comfort suspended & heated with seatbelt mounted in seat |
| <input type="checkbox"/> ALARM-E | Enhanced vehicle alarm - Thatcham H1 approved - Cab plus external sensor for body/trailer | <input type="checkbox"/> PST-STD2 | Passenger seat - Fixed non suspended with seatbelt mounted in cab |
| <input type="checkbox"/> ALCOLOCK | Alcolock | <input type="checkbox"/> PST-STD4 | Passenger seat - Standard suspended with seatbelt mounted in cab |
| <input type="checkbox"/> BUPMON | Back up monitor with built in 7" screen on dash and one colour camera supplied loose for fitment by bodybuilder. Can accommodate up to 4 cameras for TFL Safe Scheme, CLOCS and FORS. | <input type="checkbox"/> SBPRE-PS | Passenger seat belt pretensioner |
| <input type="checkbox"/> PHONE-PK | Telephone preparation kit (antenna, antenna attachm. cable incl.) | <input type="checkbox"/> ARM-DBPS | Two armrests on driver seat and one (outer) on passenger seat |
| <input type="checkbox"/> WLIFT-AD | Electrical window lift, automatic up/down driver side | <input type="checkbox"/> ARMRE-BB | Two armrests on both driver and passenger seat. |
| <input checked="" type="checkbox"/> WLIFT-EB | Electrical window lift | <input type="checkbox"/> ARMRE-DB | Two armrests, on driver seat only |
| <input type="checkbox"/> WLIFT-ME | Mechanical window lift | <input type="checkbox"/> ARMRE-PB | Two armrests, on passenger seat only |
| <input type="checkbox"/> ISUNS-BS | Side interior sun visor on both sides | <input type="checkbox"/> ARMRE-PS | Single armrest (next to driver) on passenger seat |
| <input checked="" type="checkbox"/> ISUNS-DS | Driver's side interior sun visor | <input type="checkbox"/> ARU-BAS | Vinyl upholstered armrest |
| <input checked="" type="checkbox"/> ISUNF-B | Interior front sun visor without mirror | <input type="checkbox"/> ARU-LEA | Leather upholstered armrest |
| <input type="checkbox"/> ISUNF-MD | Interior front sun visor with mirror on driver side | <input checked="" type="checkbox"/> FMAT-RUB | Rubber floor mats |
| <input type="checkbox"/> ISUNF-RE | Electrically operated textile interior sun blind | <input type="checkbox"/> FMAT-TX2 | Textile and rubber floor mats |
| <input type="checkbox"/> ISUNF-RM | Manually operated textile interior sun blind | <input type="checkbox"/> LBK-RES | Foldable rest bunk |
| <input checked="" type="checkbox"/> CSPU-S | One open storage (behind push open lid) in upper part of dash panel center section | <input type="checkbox"/> LBK70 | Lower bunk 700 x2000 mm, fixed |
| <input type="checkbox"/> ADFS | Two extra DIN slots in front shelf - can be fitted with card or drawer available as an accessory | <input checked="" type="checkbox"/> ULBK | Without lower bunk |
| <input checked="" type="checkbox"/> BUPALARM | Reverse alarm | <input type="checkbox"/> MATL-FI | Firm lower bunk pocket sprung mattress |
| <input type="checkbox"/> RTOLL-PK | Road toll PREPARATION kit for trucks operating with "Toll Collect" in Germany | <input type="checkbox"/> MATL-SF | Lower flexizone mattress - semi-firm, pocket springs up to 100kg - 16 stone |
| <input type="checkbox"/> LOADIND | Load indicator with central dashboard display | <input type="checkbox"/> MATL-SO | Lower flexizone mattress - soft, pocket springs up to 85kg - 13.5 stone |
| <input type="checkbox"/> REMC-MF | Multi-functio wireless remote control | <input type="checkbox"/> OLMAT-BA | 35mm mattress overlay protector |
| <input type="checkbox"/> FIREXT3S | 3kg fire extinguisher mounted on seat base | <input type="checkbox"/> OLMAT-PR | 50mm premium mattress overlay protector |
| <input type="checkbox"/> WARNVEST | High visibility warning vest - no sleeves | <input type="checkbox"/> TBK60F | Fixed foldable top bunk 600 x 1900mm |
| <input type="checkbox"/> AIDKIT | First aid kit | <input type="checkbox"/> TBK70F | Fixed foldable top bunk 700 x 1900mm |
| <input type="checkbox"/> AIDKIT1B | First aid kit | <input type="checkbox"/> PH-CAB2 | 1.8kW Air to air night heater |
| <input type="checkbox"/> WARNLAMP | Portable warning lamp | <input type="checkbox"/> PH-ENGCA | Engine and cab night heater |
| <input type="checkbox"/> LAMP-IN | Inspection lamp | <input type="checkbox"/> PH-SS | Short stop heater |
| <input type="checkbox"/> BULBKIT | Bulb and fuse kit | <input type="checkbox"/> SLCP-BAS | Basic sleeper control panel - includes interior light, parking heater, roof hatch and door lock |
| <input type="checkbox"/> WRITEPAD | Writing pad | <input type="checkbox"/> SAFE | Safe box for driver's personal items |
| <input type="checkbox"/> UPHTRI10 | Seats: Black embossed textile insert with light grey sides, black vinyl side bolster with blue vinyl side insert. Interior trim: Raven black bunk and curtains & blue textile side walls | <input type="checkbox"/> ETSB-F | Storage on engine tunnel - on front top |
| <input type="checkbox"/> UPHTRI11 | Seats: Light grey embossed textile insert, black raven metallic vinyl bolster with red vinyl side insert. Interior trim: Raven black bunk and curtains & grey vinyl side walls | <input type="checkbox"/> ETSB-FR | Storage on engine tunnel - on front top and at rear cab wall |
| | | <input type="checkbox"/> ETSB-FRS | Storage on engine tunnel - on front top & at rear cab wall & storage recessed into tunnel on right hand side |
| | | <input type="checkbox"/> ETSB-FS | Storage on engine tunnel - on front top and storage recessed into tunnel on right hand side |
| | | <input type="checkbox"/> ETSB-R | Storage on engine tunnel - box at rear cab wall |
| | | <input type="checkbox"/> ETSB-RS | Storage on engine tunnel - at rear cab wall and storage recessed into tunnel on right hand side |
| | | <input type="checkbox"/> ETSB-S | Storage on engine tunnel - recessed into tunnel on right hand |

Standard Equipment

Optional Equipment

For more detailed information about cab and powertrain equipment, please refer to separate specification sheets.

For all possible options and combinations of options please consult your Volvo sales contact who can create a specification to match your requirements using the Volvo Sales Support system (VSS).

The factory reserves the right to modify design and change equipment without previous notification. The specification can vary from country to country.

MODEL RANGE

FM 13 8x4 Rigid - Pusher Axle Tridem – contact sales engineering reference application

| | | | |
|-------------------------------------|------------------|---|--|
| | side | | |
| <input type="checkbox"/> | RUS-BAS | Rear cab upper storage 154 litres - 300 mm high | |
| <input type="checkbox"/> | RUS-HIG | Rear cab upper storage 245 litres - 440 mm high | |
| <input type="checkbox"/> | TABLE | Folding and height adjustable table - on lower bunk | |
| <input type="checkbox"/> | REF-ICPK | Fridge: engine tunnel mounted preparation kit | |
| <input type="checkbox"/> | REFR-RUS | Fridge: 28 litre rear upper wall mounted with dividers | |
| <input type="checkbox"/> | MICRO-PK | Preparation kit for microwave oven (wiring) | |
| <input type="checkbox"/> | BOTH-D | One bottle holder under dashboard centre section | |
| <input type="checkbox"/> | COFMA-PK | Coffee maker, preparation kit. | |
| <input checked="" type="checkbox"/> | INLI-BAS | Interior white LED lights - basic | |
| <input type="checkbox"/> | INLI-NL | Interior white and red night LED light with no dimmer | |
| <input type="checkbox"/> | INLI-NLD | Interior white and red night LED light with dimmer | |
| <input type="checkbox"/> | ARL-FLEX | Two flexible reading lamps (snake lamps) | |
| <input type="checkbox"/> | RH-ECS | Glass roof & escape hatch - Electrically operated | |
| <input type="checkbox"/> | RH-EE | Without roof hatch -Tinted glass emergency exit ONLY | |
| <input type="checkbox"/> | RH-ETR | Glass roof & escape hatch - Electrically operated, tinted glass with rear opening | |
| <input type="checkbox"/> | RH-MSR | Steel roof & escape hatch - Manually operated with rear opening | |
| <input type="checkbox"/> | RH-MTR | Glass roof & escape hatch - Manually operated, tinted glass with rear opening | |
| <input checked="" type="checkbox"/> | URH | Without roof hatch | |
| <input type="checkbox"/> | SWIND-BS | Extra side window on both sides behind "B" pillar | |
| <input type="checkbox"/> | SWIND-PS | Rear side window, passenger side | |
| <input type="checkbox"/> | VANMIR | Vanity mirror in front shelf | |
| <input type="checkbox"/> | AS-FUS | Extra shelf in front upper storage compartments | |
| <input type="checkbox"/> | INFOT-PK | Preparation kit for the mounting of a flat screen TV in cab above the driver's door, includes bracket, electrical and speaker connections | |
| CAB EXTERIOR | | | |
| <input type="checkbox"/> | PAICS-B | Basic cab paint - mirrors, sunvisor, instep and bumper supplied in natural finish - grey | |
| <input type="checkbox"/> | PAICS-C | Complete cab - mirrors, insteps, sunvisor, and bumper finished in cab colour | |
| <input checked="" type="checkbox"/> | GLAS-TIN | Tinted windows. | |
| <input type="checkbox"/> | AWIND-RF | Rear window | |
| <input type="checkbox"/> | DGLAS-L | Laminated door glass | |
| <input checked="" type="checkbox"/> | LOCK-MAN | Manual door locking | |
| <input type="checkbox"/> | LOCK-MRP | Manual door locking with internal remote control (from driver side) of passenger door | |
| <input type="checkbox"/> | LOCK-REM | Central locking with remote control | |
| <input type="checkbox"/> | BUMP-B | Plastic front bumper | |
| <input checked="" type="checkbox"/> | BUMP-B2 | Steel front bumper | |
| <input type="checkbox"/> | BUMP-SP | Front bumper spoiler | |
| <input type="checkbox"/> | GUARD-EH | Engine guard to protect sump and engine hoses | |
| <input checked="" type="checkbox"/> | BUGNET | Insect screen in front of radiator | |
| <input type="checkbox"/> | CTILT-P-E | Electrically operated hydraulic cab tilt | |
| <input checked="" type="checkbox"/> | CTILT-P-M | Manually operated hydraulic cab tilt | |
| <input type="checkbox"/> | FCABS-A | Front cab suspension - Air | |
| <input checked="" type="checkbox"/> | FCABS-M | Front cab suspension - Mechanical spring | |
| <input type="checkbox"/> | RCABS-A | Rear cab suspension - Air | |
| <input checked="" type="checkbox"/> | RCABS-M | Rear cab suspension - Mechanical spring | |
| <input type="checkbox"/> | MIRCOMF2 | Electrically heated and operated FMX style main and wide-angle mirror on both sides, with manual passenger kerb mirror. To increase direct vision to the side the main mirrors have no cowlings | |
| <input type="checkbox"/> | MIRCOMFM | Electrically heated and operated main with manual wide-angle mirror - both sides - and passenger kerb mirror | |
| <input type="checkbox"/> | MIRSTD2 | Electrically heated - FMX - main with wide angle mirror on both sides and kerb view mirror on passenger side, to increase | |
| | | | MIRSTDFM direct vision to the side the main mirrors have no cowlings Electrically heated main mirror with wide angle mirror on both sides and kerb view mirror on passenger side |
| | | | AMIR-F20 Auxiliary front view mirror with a 200mm radius |
| <input type="checkbox"/> | SUNV-H | External smoke grey sunvisor | |
| <input type="checkbox"/> | AD-ROOF | Roof air deflector | |
| <input type="checkbox"/> | AD-SIDEL | Side air deflector extension panels | |
| <input type="checkbox"/> | AD-SIDES | Short cab side air deflector for rigid bodywork | |
| <input type="checkbox"/> | HL-BAS2 | Halogen H1 head lamps | |
| <input checked="" type="checkbox"/> | HL-BASIC | Halogen H7 head lamps | |
| <input type="checkbox"/> | HL-BHID | High intensity Bi-Xenon head lamps | |
| <input type="checkbox"/> | HL-BHID2 | Dynamic high intensity Bi-Xenon head lamps These follow the steering movement and direction of the truck Bi-Xenon high intensity discharge and dynamic head lamps. Dipped beam follows the road, activated by a signal from the steering system. | |
| <input type="checkbox"/> | HL-DBL | | |
| <input type="checkbox"/> | HL-CLEAN | Head lamp cleaner - washer jets | |
| <input type="checkbox"/> | HLP-ST | Headlamp protection | |
| <input type="checkbox"/> | HLP-ST2 | Mesh headlamp protection | |
| <input type="checkbox"/> | HL-ADJ | Headlight adjustment - Switch in cab | |
| <input type="checkbox"/> | DRIVL2 | Two spot lamps | |
| <input checked="" type="checkbox"/> | UDRIVL | Without auxiliary driving lights | |
| <input checked="" type="checkbox"/> | FOGL-WC | Front fog lights | |
| <input type="checkbox"/> | CL-STAT | Static corner lights | |
| <input type="checkbox"/> | ASL-RF2 | Two Hella H11 70W spotlamps in sign box - only available with the basic headlight and no lower driving lights. | |
| <input type="checkbox"/> | ASL-RFPK | Preparation kit for two spotlamps in sign box | |
| <input type="checkbox"/> | BEACOA2F | Two front roof mounted amber beacon rotating warning lamps | |
| <input type="checkbox"/> | BEACOA2R | Two rear roof mounted (on accessory bracket) amber beacon flashing warning LED lamps | |
| <input type="checkbox"/> | BEACON-P | Roof beacon wire preparation | |
| <input type="checkbox"/> | BEACONA4 | Four roof mounted (2 front/2 rear) amber beacon rotating warning lamps | |
| <input type="checkbox"/> | CABPT-R1 | Single outlet for roof mounted accessories | |
| <input checked="" type="checkbox"/> | CABPT-R2 | Twin outlets for roof mounted accessories. | |
| <input type="checkbox"/> | SPOTP-F | Spotlamp preparation in front, max 280W | |
| <input type="checkbox"/> | SPOTP-R | Spotlamp preparation on roof, max 280W | |
| <input type="checkbox"/> | SPOTP-RF | Spotlamp preparation on cab roof and in cab front, max 2x280W | |
| <input type="checkbox"/> | ROS-IL2 | Preparation kit for illuminated roof sign with switch loose in cab, fit after registration | |
| <input type="checkbox"/> | CSGN-GTR | "Globetrotter" headboard logo | |
| <input checked="" type="checkbox"/> | HORN-F1S | Single tone Jericho air horn chassis mounted | |
| <input type="checkbox"/> | HORN-R2S | Two roof mounted air horns | |
| <input type="checkbox"/> | ANT-CBR | Roof mounted antenna for CB radio, single aerial | |
| <input type="checkbox"/> | ACCBP-AP | Front, middle & rear roof mounted accessory brackets | |
| <input type="checkbox"/> | ACCBP-F | Front roof mounted accessory bracket | |
| <input type="checkbox"/> | ACCBP-FM | Front & middle roof mounted accessory brackets | |
| <input type="checkbox"/> | ACCBP-FR | Front & rear roof mounted accessory brackets | |
| <input type="checkbox"/> | ACCBP-M | Middle roof mounted accessory bracket | |
| <input type="checkbox"/> | ACCBP-R | Rear roof mounted accessory bracket | |
| <input type="checkbox"/> | ACCBP-RM | Rear & middle roof mounted accessory brackets | |
| <input type="checkbox"/> | REFS-TW | White cab conspicuity markings by packed in cab | |
| <input type="checkbox"/> | REFS-TY | Yellow cab conspicuity markings by packed in cab | |
| SUPERSTRUCTURE PREPARATIONS | | | |
| <input type="checkbox"/> | SRWL-PK | Wiring preparation for side & rear work/reverse lamps on side of chassis and a three-position switch, maximum 280W | |
| <input type="checkbox"/> | SWL-2FW | Two H3 70W white front chassis mounted (LH/RH side) working lamps and a 2-position switch (On/Off) | |
| <input type="checkbox"/> | SWL-2RW | Two H3 70W white rear chassis mounted (LH/RH side) working lamps and a 2-position switch (On/Off) | |
| <input type="checkbox"/> | SWL-4W | 4 H3 70W white front (2) & rear (2) chassis mtd (LH/RH side) | |

Standard Equipment

Optional Equipment

For more detailed information about cab and powertrain equipment, please refer to separate specification sheets.

For all possible options and combinations of options please consult your Volvo sales contact who can create a specification to match your requirements using the Volvo Sales Support system (VSS).

The factory reserves the right to modify design and change equipment without previous notification. The specification can vary from country to country.

MODEL RANGE

FM 13 8x4 Rigid - Pusher Axle Tridem – contact sales engineering reference application

- **SWL-PK** working lamps & 2-pos switch (On/Off)
Wiring preparation for side work/reverse lamps on side of chassis and a three-position switch, maximum 280W
- **WLC-H2A** Two H3/70W working lamps with amber coloured lens high mounted back of cab
- **WLC-H2W** Two H3/70W white working lamps high mounted on the back of cab
- **WLC-PKCH** Preparation kit (cables and switch) for cab mounted chassis working lamp
- **WLC-PKH** Preparation kit, cables and switch for high mounted working lamps back of cab
- **WLC-PKL** Preparation kit, cables and switch for low mounted working lamps back of cab
- **WLC-PKLH** Preparation kit - cables and switch for low and high mounted working lamps back of cab.
- **ECBB-BAS** Body builder electrical centre without body builder module
- **ECBB-HIG** Body builder electrical centre with body builder module
- **BBCHAS1** One 7-pole connector for Body builder interface
- **BBCHAS3** Three 7-pole connectors for Body builder interface
- **BEPR-T2** Body builder electrical software preparation for tipper with remote control
- **EXSTER** External steering control, with VDS and bodybuilder module
- **TD-BAS** Trailer detection WITHOUT LED sensing
- **TD-LED** Trailer detection with LED sensing
- **FRFS-BS** Frame rail free space on both sides to give space for crane legs or other equipment.
- **FBA-BTF** Lower front body attachments for torsionally flexible - platform body
- **FBA-BTSF** Lower front body attachments for torsionally semi-flexible body - box or curtainsider
- **HBA-FSFB** Holes for body attachments - flexible/semi-flexible body
- **HBA-SB** Holes for body attachments - stiff body
- **RBA-T2** Lower rear body attachments for helper frame
- **CRANEPK1** Crane plates mounted to frame, for cranes up to 10 tonne metre capacity
- **CRANEPK2** Crane plates mounted to frame, for cranes up to 20 tonne metre capacity
- **CRANEPK4** Crane plates mounted to frame, for cranes up to 40 tonne metre capacity
- **AUXL-SPK** Electrical preparation kit - wiring and switch for snow plough lights
- **TAILPRE2** Tail lift preparation kit, wireless remote operation
- **TAILPREP** Taillift preparation kit - cab switch and warning in driver display
- **AESW2** Two Body builder bistable electrical switches (marked AUX1 / AUX2)
- **AESW2PK** 2 Body builder bistable el.switches (marked AUX1/AUX2) and prep. for 4 more switches
- **AUXSW-4** Wiring for 4 extra switches (from Body builder electrical centre to switch positions)

DELIVERY SERVICES

- **TGW-4GWL** GSM/GPRS/4G modem, LTE & WLAN for telematics gateway
- **FMS-PK** Fleet Management System gateway



Volvo Truck Corporation
volvotrucks.com