

MODEL RANGE

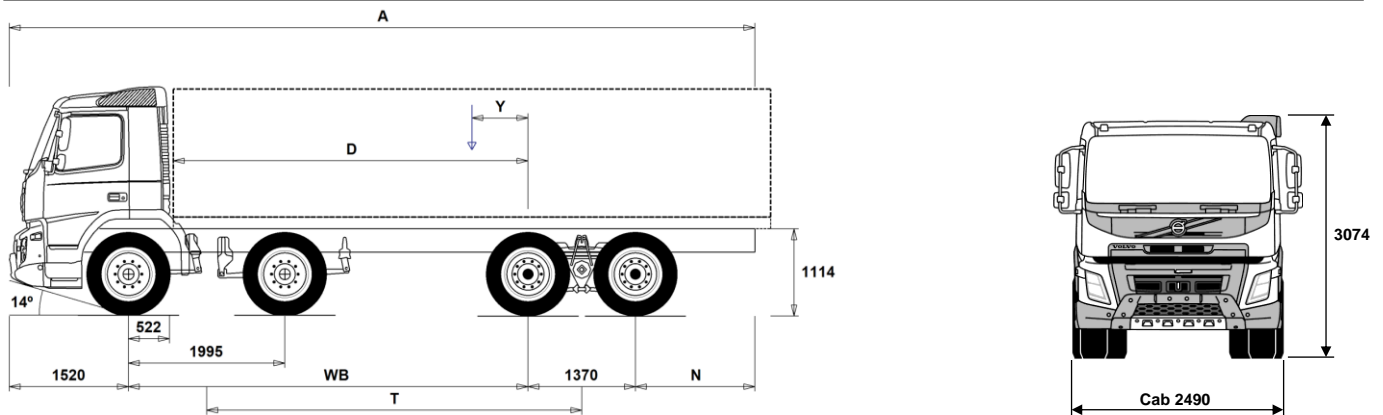

Volvo Trucks. Driving Progress

FMX13 8x4 Rigid - High T Ride - N3 Cranked front axle for on road work FM 84F R3HTX



Chassis Dimensions [mm]

WB Wheelbase	5100	5600
A Overall Chassis Length	10815	11565
D Center of rear axle to front of body	4528	5028
N Rear Overhang (Min.)	1225	1225
N Rear Overhang (Max.)	2825	3075
T Theoretical Wheelbase	4788	5288
Y Center of Gravity for Payload (Min.)	711	871
Y Center of Gravity for Payload (Max.)	1355	1585

Chassis Weights [kg]

Front Axles	6490	6450
Rear Bogie	3195	3305
Kerb Weight	9685	9755
Payload (including body, driver, fuel, etc.)	22315	22245

Turning Diameter [mm]

Turning Circle Diameter Kerb to Kerb	20600	22200
Turning Circle Diameter Wall to Wall	22100	23700

Plated Weights [kg]

	Plated	Design
Gross Vehicle Weight	32000	42000
Gross Combination Weight	44000	44000
Front Axles	16000	16000
Rear Bogie	19000	26000

Important Notes

Chassis Dimensions

Cab Height: +416 mm for CAB-HSLP.
 Front Axle to Back of Cab: +424 mm for CAB-HSLP and CAB-SLP.
 D-measure includes a front clearance of 50 mm and for rigid trucks also a subframe of 100 mm.
 Height can vary ± 20 mm for leaf and ± 10 mm for air suspension.
 All dimensions are for unladen chassis and any tag axles down.
 Rear overhang used for vehicle weight calculation is the maximum rear overhang (N Max.) for selected wheelbase.

Weight and dimensions are based upon the following tyres:

Front Axle Tyres:	315/80R22.5
Drive Axle Tyres:	315/80R22.5

Chassis weight includes oil, water, AdBlue, 0 litres fuel and without driver. Kerb weight can vary $\pm 3\%$.

Turning diameters are theoretically calculated.

Legal weights can differ from country to country.

For more detailed weight information, including optional equipment weights, ask your Volvo sales contact to enter your specification into the Volvo Weight Information system (WIS).

Do NOT use this drawing for bodybuilding. Refer to Volvo Bodybuilder Instructions and chassis assembly drawing FM84FR3HTX.

MODEL RANGE

FMX13 8x4 Rigid - High T Ride - N3 Cranked front axle for on road work FM 84F R3HTX

TRUCK USE

- PTO-HT16** High torque power take-off up to 1600Nm
- PTO-HT20** High torque power take-off up to 2000Nm
- RC-ROUGH** Operating class on/off road
- RC-VROUG** Very rough road conditions
- TIPP-PRE** Tipper vehicle preparation
- UNIFORM** Basic platform vehicle

CORE COMPONENTS

- CHH-HIGH** Chassis height high - N3 "On Road" chassis - For a specific loading height always check the unique BEP chassis drawing
- RADD-TR1** T-ride 1 rear two spring bogie suspension, 75mm wide springs
- RADD-TR2** T-ride 3 rear two spring bogie suspension, reinforced
- FMX-DAY** Day cab - with steel safety cage design
Designed and built to Swedish impact and ECE R29 regulations
- FMX-HSLP** Globetrotter cab - with steel safety cage design
Designed and built to Swedish impact and ECE R29 regulations
- FMX-SLP** Sleeper cab - with steel safety cage design
Designed and built to Swedish impact and ECE R29 regulations
- EU6SCR** Emission level - Euro 6
- D13 420S** D13K420 12.8 litre engine developing 420hp at 14-1800rpm.
Peak torque 2100Nm at 860 -1400rpm.
- D13 460S** D13K460 12.8 litre engine developing 460hp at 14-1800rpm.
Peak torque 2300Nm at 900-1400rpm.
- D13 500S** D13K500 12.8l engine developing 500hp at 14-1800rpm.
Peak torque 2500Nm at 1000-1400rpm.
- D13 540S** D13K540 12.8l engine developing 540hp at 14-1800rpm.
Peak torque 2600Nm at 1000-1450rpm.
- D13K420** D13K420 - 420hp engine
- D13K460** D13K460 - 460hp engine
- D13K500** D13K500 - 500hp engine
- D13K540** D13K540 - 540hp engine
- EBR-EPG** Exhaust brake controlled by steering column switch
- EBR-EPGC** Exhaust pressure governor for I shift gearbox
- EBR-VEB+** Volvo engine brake + and exhaust pressure governor, enhanced performance from additional exhaust rocker control. Retardation 375kW
- AT2612F** AT2612F 12-speed "I-shift" automated mechanical gearbox suitable for gross train weights up to 60tonne only refer to sales engineering when used in conjunction with a PTO
- ATO2612F** ATO2612F 12-speed "I-shift" overdrive automated mechanical gearbox suitable for gross train weights up to 60tonne refer to sales engineering when used in conjunction with a PTO
- PT2606** Powertronic automatic 6-speed gearbox, max. engine torque 2600 Nm, max. permitted GCW 130000 kg
- SPO2812** SPO2812 - 12 speed I-shift Dual Clutch automated mechanical gearbox GCW 60tonne
- RTH2610F** RTH2610F hub reduction tandem 26tonne drive axles, GCW 100 tonnes with differential and cross locks*
* Cross locks replaced by a dog clutch if tandem axle lift is specified
- RTH3210F** RTH3210F hub reduction tandem 32 tonne drive axles, GCW 100 tonnes with differential and cross locks*
* Cross locks replaced by a dog clutch if tandem axle lift is specified
- RTH3312** RTH3312 hub reduction tandem 33tonne drive axles, GCW 120 tonnes with differential and cross locks*
* Cross locks replaced by a dog clutch if tandem axle lift is specified
- RTS2370A** RTS2370A single reduction tandem 23tonne drive axles with differential and cross locks* - design GCW 70tonnes.
* Cross locks replaced by a dog clutch if tandem axle lift is specified.

Standard Equipment

Optional Equipment

For more detailed information about cab and powertrain equipment, please refer to separate specification sheets.

For all possible options and combinations of options please consult your Volvo sales contact who can create a specification to match your requirements using the Volvo Sales Support system (VSS).

The factory reserves the right to modify design and change equipment without previous notification. The specification can vary from country to country.

PACKAGES

- DRIVEFM** Cab Package: Drive
- DRIVEFM+** Cab Package: Drive +
- BEDFM** One bed resting package
- AUDHIG** High Power Audio system: RDS radio with CD player - also playing MP3/WMA files from CD -, with integrated bluetooth phone and USB/Line inputs. FM/AM antenna, speakers in dashboard, doors, and sleeping compartment.
- MEDIA** AM/FM Bluetooth radio without CD player. USB and Aux line inputs. Speakers in dashboard, doors, and sleeping compartment. 7" touch screen with personal apps.
- MEDIADF** AM/FM Bluetooth radio without CD player. USB and Aux line inputs. Speakers in dashboard, doors, and sleeping compartment. 7" touch screen with personal and professional apps. Dynafleet vehicle on-board data display with office internet support.
- MEDIANAV** AM/FM Bluetooth radio without CD player. USB and Aux line inputs. Speakers in dashboard, doors, and sleeping compartment. 7" touch screen with personal and professional apps. Truck based satellite navigation (live updates not included)
- MEDIANDF** AM/FM Bluetooth radio without CD player. USB and Aux line inputs. Speakers in dashboard, doors, and sleeping compartment. 7" touch screen with personal and professional apps. Truck based satellite navigation (live updates not included) Dynafleet vehicle on-board data display with office internet support.
- RCHAPAC1** Chassis Package Rigid

CHASSIS

- FST-PAR** Front suspension type - 2 leaf parabolic springs
- FST-PAR3** Front suspension type - 3 leaf parabolic springs
- FAL16.0** Front axles design capacity 16 tonnes - 2 x 8.0 tonne front axles
- FAL18.0** Front axles design capacity 18 tonnes - 2 x 9 tonne front axles - check tyre load index
- FAL20.0** Front axles design capacity 20 tonnes - 2 x 10.0 tonne front axles only available with front air suspension.
- FSM-LUB** Lubricated rear shackles on front suspension pins and bushings
- FSTAB** Front anti-roll bar
- FSTAB2** Front anti-roll bar medium stiffness
- FSTAB3** Front stiff anti-roll bar
- RAL23** Rear bogie design capacity 23 tonnes
- RAL26** Rear bogie design capacity 26 tonnes
- RAL32** Rear bogie design capacity 32 tonnes
- RSTAB1** Rear anti-roll bar
- RSAP2** Heavy duty rear suspension application (with reinforcements)
- ACTST-TO** Volvo Dynamic Steering (VDS) with with extra electronic pump and torque overlay
- ASFE-BAS** Active steering feature - Basic - Volvo Dynamic Steering only
- ASFE-PS** Active steering feature - Volvo Dynamic Steering with personal settings
- PSS-DUAL** Dual power steering system
- PSP-VAR** Power steering pump with variable displacement
- EBS-MED** EBS medium package including "hill" hold function
- AUXPARK** Additional spring parking brakes
- RST-MUL** Rear Suspension, Multi-leaf springs
- RST-PAR1** Rear Suspension, Parabolic springs
- RST-PAR5** Rear Suspension, Progressive parabolic springs
- FBREG-E** Front regulating brake valve, EBS

MODEL RANGE

FMX13 8x4 Rigid - High T Ride - N3 Cranked front axle for on road work FM 84F R3HTX

- **FRAME300** Frame rail section external height 300 mm
 - **FST8080** Frame thickness - web and flange 8.0mm
 - **FIL-EEEB** Inner liner from end of engine to end of bogie
 - **FIL-EEEF** Inner liner from end of engine to end of frame
 - **FIL-FBEB** Inner liner over rear bogie
 - **FIL-FBEF** Inner liner from front of bogie to end of frame
 - **FIL-TXEB** Inner liner from gearbox member to end of bogie
 - **FIL-TXEF** Inner liner from gearbox member to end of frame
 - **BBOX-L** Battery box located on left hand side
 - **2BAT210B** 2 x 210 Ah capacity Gel batteries
 - **2BATT170** 2 x 170 Ah capacity batteries
 - **2BATT225** 2 x 225 Ah capacity batteries
 - **BATTAMP** Battery voltage and ampere gauge
 - **BATTIND** Battery charge indication
 - **ADR2** ADR package for transportation of dangerous goods on road (Note does NOT include safe loading pass package if required this is quoted separately)
 - **MSWI-A** Main switch - ADR switch circuit shut down
 - **MSWI-C** Main switch - Chassis mounted toggle switch by battery box
 - **MSWI-R** Main switch - Key fob operated remote controlled
 - **UR-FUEL** Without right fuel tank
Min volume 255l
Max volume 810l
 - **UL-FUEL** Without left fuel tank
Min volume 160l
Max volume 450l
 - **ADTP-L** AdBlue tank on left hand side
 - **ADTP-LF** AdBlue tank on left hand side at the front
 - **ADTP-R** AdBlue tank on right hand side
 - **ADB032** AdBlue tank usable volume 32 litres
 - **ADB048** AdBlue tank usable volume 48 litres
 - **ADB064** AdBlue tank usable volume 64 litres
 - **FCAP-L** Locking fuel filler cap
 - **FUFF-AS** Fuel filling anti-spillage device
 - **FUFF-ATS** Fuel filling anti-theft and anti-spillage devices
 - **ESH-LEFT** Horizontal silencer, left exhaust outlet
 - **ESH-REAR** Horizontal silencer, rear exhaust outlet
 - **ESH-RIGH** Horizontal silencer, right exhaust outlet
 - **ESH-VERT** Horizontal silencer, vertical exhaust outlet
 - **ESHVVERT** Horizontal chassis mounted diesel particulate filter and vertical SCR silencer behind cab
 - **EXST-SSP** Stainless steel exhaust stack - NOT polished
 - **EXST-ST** Steel exhaust stack
 - **WHC-FIX2** Two fixed wheel chocks
 - **WHC-FOL2** Two foldable wheel chocks
 - **WHCP-F** Wheel chock(s) stored in the front part of the vehicle
 - **WHCP-R** Wheel chock(s) stored in the rear part of the vehicle
 - **WHCP-T** Transport mounted wheel chock(s) stored in cab outer luggage locker
 - **TB-L80** Toolbox 800 mm, left side
 - **TB-R80** Toolbox 800 mm, right side
 - **SUP-BAS** EC approved chassis side guards
 - **SUP-LOW** EC approved low chassis side guards
 - **CHAIN-S** Snow chains
 - **HOOK-SC** Snow chain hooks
 - **TOWF-HD1** One heavy duty front towing device
 - **TOWMBRH** Towing member, high mounted in centre of frame, D = 190
 - **TOWMBRL1** Towing member, low mounted under the frame
 - **TOWMBRM** Towing member, medium mounted in line with frame lower flange
 - **RFEC-S** Rear frame end, straight cut for regular platform applications
 - **RFEC-U** Rear frame end, upper cut for tipper applications.
 - **C-RI4040** Towing coupling, Ringfeder 4040 G-150
 - **C-RI5055** Towing coupling, Ringfeder 5055 G-150
 - **C-RO400G** Towing coupling, Rockinger 400 G-150 for 40mm eyes
 - **C-RO50** Rockinger RO 50 50mm for centre axle trailer
 - **TOWR-ONE** Towing hitch attached to rear crossmember
 - **TREL-PK** Trailer electrical preparation kit - chassis/cab wiring
 - **TREL14** Single 14 pole electrical trailer connector
 - **TREL15** Single 15 pole electrical trailer connector - ADR certified
 - **TREL7** 7 pole - 24N trailer electrical suzie
 - **TREL7-7** 24N and 24S trailer electrical suzies
 - **TBC-DUO** Duomatic type air line connectors
 - **TBC-EC** Palm coupling type air line connectors
 - **TRBR-HCF** Full pressure hand controlled trailer brake
 - **TRBR-STA** Stationary trailer brake control
 - **TRB-STRE** Stretch Brake - Automatic low speed trailer brake activation to avoid jack-knifing and improve steerability
 - **RUP-FOSL** Folding & sliding EC approved aluminium rear underrun
 - **FFEND-B** Standard mounted mud wings on second front axle
 - **FFEND-T** Transport mounted mud wings on second front axle
 - **RFEND-B** Three piece EC approved rear mud wings and spray flaps
 - **RFEND-T** Rear mud wings, transport mounted
 - **RFH-BAS** Basic rear wing height
 - **RFH-HIG** High rear wing height - higher wing tops
 - **RFH-LOW** Lower rear wing height - shallower wing tops
 - **ATANK-AL** Aluminium air tanks
 - **ATANK-ST** Steel air tanks
 - **TL-LED** Rear lights LED
 - **BLIGHT-E** Emergency brake light
- ### WHEELS & TYRES
- **RT-AL** Alcoa brushed aluminium rims with standard holes for long stud fixing on all axles
 - **RT-ALDP** Alcoa Dura-Bright EVO aluminium rims with standard holes long stud fixing on all axles, requires cleaning with a ph neutral solution - washing up liquid.
 - **RT-ALDPD** Alcoa Dura-Bright EVO aluminium rims with countersunk holes for short stud fixing on all axles, requires cleaning with a ph neutral solution - washing up liquid.
 - **RT-ALDU** Alcoa brushed aluminium rims with countersunk holes for short stud fixing on all axles
 - **RT-SPOKE** Spoke rims on all axles
 - **RT-STEEL** Steel rims on all axles
 - **WCAP** Aerodynamic hub caps
 - **SPWT-D** Spare wheel & tyre with rear tyre pattern
 - **SPWT-F** Spare wheel & tyre with front tyre pattern
 - **SWCP-LF** Spare wheel carrier on left side of chassis ahead of rear axle
 - **SWCP-T** Spare wheel supplied temporarily strapped to chassis
 - **SWCP-TP** Temporary spare wheel carrier on top of chassis frame
 - **JACK-12T** 12 tonne bottle jack
 - **JACK-15T** 15 tonne bottle jack
 - **JACK-20T** 20 tonne bottle jack
 - **TOOL-BAS** Basic Toolkit
 - **TOOLKIT** Complete tool kit
 - **INFLAHOS** Tyre inflation hose
 - **GAUGE-TP** Tyre pressure gauge
- ### DRIVELINE EQUIPMENT
- **ASO-C** Crawler gear -
Ratio direct top gearbox 19:1
Ratio Overdrive gearbox 17:1
 - **ASO-ULC** Ultra low crawler and crawler gear -
Ratios direct top gearbox 32:1 and 19:1
Ratios Overdrive box 32:1 and 17:1

■ Standard Equipment

□ Optional Equipment

For more detailed information about cab and powertrain equipment, please refer to separate specification sheets.

For all possible options and combinations of options please consult your Volvo sales contact who can create a specification to match your requirements using the Volvo Sales Support system (VSS).

The factory reserves the right to modify design and change equipment without previous notification. The specification can vary from country to country.

MODEL RANGE

FMX13 8x4 Rigid - High T Ride - N3 Cranked front axle for on road work FM 84F R3HTX

- TRAP-HD** Reinforced gearbox application
- TP-CON** Construction Package
- TP-DIST** Distribution Package
- TP-HD** I-shift software - Heavy duty for high GCW
Special conditions apply consult Sales Engineering
- TP-LONG** Long Haul Package
- AMSO-AUT** Enhanced I-shift software with manual shift available in auto mode and kickdown facility on accelerator pedal
- AVO-ENH** Enhanced software for off road driveability and starting
- APF-ENH** I-shift enhanced PTO functions
- CD43-O** Dual plate clutch, plate diameter 430 mm
- RET-TH** Gearbox mounted retarder
- RET-TPT** Hydraulic Retarder for Powertronic gearbox
- TC-HWO** Automatic gearbox oil cooler - water to oil
- TC-MAOH2** Extra high performance transmission oil cooler - air to oil with front mounted radiator
- TC-MWO** Basic transmission oil cooler - water to oil
- 1COMP530** Single cylinder, air compressor, 530 litres per minute
- 2COM1100** Two cylinder, air compressor, 1100 litres per minute
- 2COMP900** Two cylinder, air compressor, 900 litres per minute
- CLU-AIRC** Clutchable air compressor
- AIRIN-HI** Roof mounted air intake behind cab on left hand side
- AIRIN-LO** Low level air intake behind cab on left hand side
- ACL1ST-S** Two stage air filter
- 24AL110B** 110 amp alternator
- 24AL120B** 120 amp alternator
- 24AL150B** 150 amp alternator
- CCV-C** Closed crankcase engine ventilation
- CCV-O** Open crankcase engine breather
- CCV-OX** Closed crankcase ventilation for cold markets
- PRIM-EL** Electrical priming pump
- PRIM-MAN** Manual priming pump
- FUEQ-EH** Fuel line electric heater
- AF-R** Hot fuel recirculation heated fuel filter
- FUEFE2LW** Large engine mounted dual fuel filter with water separator
- FUEFE2SW** Small engine mounted dual fuel filter with water separator
- EST-AID** Air inlet manifold starting heater element
- 220EBH15** 220V/1.5Kw electric engine block heater
- PTER-100** Rear engine mounted power-take-off with DIN 100 / ISO 7646 flange
- PTER-DIN** Rear engine mounted PTO with DIN5462 (female) splined shaft for a close coupled pump.
Models with 3 steering axles will use this to drive the steering pump (AUXPSP)
- PTER1400** Rear engine mounted power-take-off with SAE 1410 flange
- HPE-F101** Parker F1-101, engine mounted, fixed displacement, single flow, engine mounted hydraulic pump
- HPE-F41** Parker F1-41, engine mounted, fixed displacement, single flow, engine mounted hydraulic pump
- HPE-F51** Parker F1-51, engine mounted, fixed displacement, single flow, engine mounted hydraulic pump
- HPE-F61** Parker F1-61, engine mounted, fixed displacement, single flow, engine mounted hydraulic pump
- HPE-F81** Parker F1-81, engine mounted, fixed displacement, single flow, engine mounted hydraulic pump
- HPE-T53** Parker F2-53/53, engine mounted, Fixed displacement, Twin flow engine mounted hydraulic pump
- HPE-T70** Parker F2-70/35, engine mounted, Fixed displacement, Twin flow engine mounted hydraulic pump
- HPE-V45** Parker VP1-45, variable displacement, single flow, engine mounted hydraulic pump
- HPE-V75** Parker VP1-75, variable displacement, single flow, engine mounted hydraulic pump
- PTPT-D** Powertronic PTO, 1 front/upper DIN connection for plug-in pump (max. 850 Nm)
- PTPT-F** Powertronic PTO, 1 front/upper rear facing SAE flange conn. for prop shaft (max.850 Nm)
- PTR-D** Gearbox PTO for plug-in pump, 0.71xeng speed
- PTR-DH** Gearbox driven high speed PTO for one plug-in hydraulic pump
- PTR-DM** Gearbox driven medium speed PTO for one plug-in hydraulic pump
- PTR-F** Gearbox driven PTO with rear flange connection
- PTRD-D** Gearbox driven HIGH SPEED PTO for two plug-in hydraulic pumps
- PTRD-F** PTO with 1 DIN + 1 flange connection rear, manual gearbox
- HPG-F101** Parker F1-101 gearbox mounted, fixed displacement, single flow, hydraulic pump
- HPG-F41** Parker F1-41 gearbox mounted, fixed displacement, single flow, hydraulic pump
- HPG-F51** Parker F1-51 gearbox mounted, fixed displacement, single flow, hydraulic pump
- HPG-F61** Parker F1-61 gearbox mounted, fixed displacement, single flow, hydraulic pump
- HPG-F81** Parker F1-81 gearbox mounted, fixed displacement, single flow, hydraulic pump
- EIDLESD** Engine idle shut down
- STWPOS-R** RIGHT HAND DRIVE
- STWM-LE** Leather steering wheel
- STGW-AD2** Adjustable steering wheel with neck tilt
- STGW-ADJ** Adjustable steering wheel
- AIRBAG** SRS Driver's air bag
- DRC-AMII** DPF Regeneration control switch - for manual and switching off regeneration
- 1DAYDIG2** Continental VDO DTCO 4.0 smart tachograph
This tachograph can ONLY offer remote download if the option of Dynafleet or an FMS gateway has been specified with this order.
- 1DAYDIGP** Continental VDO DTCO 3.0 digital tachograph
For vehicles with long lead time - this includes prep kit for the retrofit of DTCO 4.0 tachograph.
For updating to new legal demand for trick registration from 15th June 2019.
This tachograph can ONLY offer remote download if the option of Dynafleet or an FMS gateway has been specified with this order.
- ARSL** Additional road speed limit - switch in dashboard
- CRUIS-E** Eco cruise control (with eco-roll and I-cruise, controls in steering wheel)
- CRUISEC** Cruise control, standard
- ESP-BAS1** Electronic Stability Control
- ESPC-RO** ESP (Electronic Stability Program) functionality control - Reduced / Off
- HWSS-ACB** Adaptive cruise control ACC with forward collision warning and AEBS advanced emergency brake system
- HWSS-FCB** Forward collision warning with AEBS advanced emergency brake system
- LSS-DW** Lane departure-warning system
- LCS** Lane change support
- DAS-W** Driver Alert Support system
- RSENS-W** Rain sensing windscreen wipers
- CU-ECC** Electrically controlled air conditioning with sun sensor
- CU-ECC2** Electrically controlled air conditioning with sun sensor, mist sensor, air quality sensor and carbon filter
- CU-MCC** Climate unit with manual controlled air conditioning

Standard Equipment

Optional Equipment

For more detailed information about cab and powertrain equipment, please refer to separate specification sheets.

For all possible options and combinations of options please consult your Volvo sales contact who can create a specification to match your requirements using the Volvo Sales Support system (VSS).

The factory reserves the right to modify design and change equipment without previous notification. The specification can vary from country to country.

MODEL RANGE

FMX13 8x4 Rigid - High T Ride - N3 Cranked front axle for on road work FM 84F R3HTX

■ IMMOBIL	Thatcham H2 approved immobiliser	■ PST-BAS1	Passenger seat - Fixed non suspended fold up with seatbelt mounted in cab
□ ALARM-B	Thatcham H1 approved vehicle alarm - Cab only	□ PST-BENC	Bench passenger seat
□ ALARM-E	Enhanced vehicle alarm - Thatcham H1 approved - Cab plus external sensor for body/trailer	□ PST-CF4	Passenger seat - Comfort suspended with seatbelt mounted in seat
□ ALCOLOCK	Alcolock	□ PST-CF5	Passenger seat - Comfort suspended & heated with seatbelt mounted in seat
□ BUPMON	Back up monitor with built in 7" screen on dash and one colour camera supplied loose for fitment by bodybuilder. Can accomodate up to 4 cameras for TfL Safe Scheme, CLOCS and FORS.	□ PST-STD2	Passenger seat - Fixed non suspended with seatbelt mounted in cab
□ PHONE-PK	Telephone preparation kit (antenna, antenna attachm. cable incl.)	□ PST-STD4	Passenger seat - Standard suspended with seatbelt mounted in cab
□ WLIFT-AD	Electrical window lift, automatic up/down driver side	□ SBPRE-PS	Passenger seat belt pretensioner
■ WLIFT-EB	Electrical window lift	□ ARM-DBPS	Two armrests on driver seat and one (outer) on passenger seat
□ WLIFT-ME	Mechanical window lift	□ ARMRE-BB	Two armrests on both driver and passenger seat.
□ ISUNS-BS	Side interior sun visor on both sides	□ ARMRE-DB	Two armrests, on driver seat only
■ ISUNS-DS	Driver's side interior sun visor	□ ARMRE-PB	Two armrests, on passenger seat only
■ ISUNF-B	Interior front sun visor without mirror	□ ARMRE-PS	Single armrest (next to driver) on passenger seat
□ ISUNF-MD	Interior front sun visor with mirror on driver side	□ ARU-BAS	Vinyl upholstered armrest
□ ISUNF-RE	Electrically operated textile interior sun blind	□ ARU-LEA	Leather upholstered armrest
□ ISUNF-RM	Manually operated textile interior sun blind	■ FMAT-RU2	Rubber floor mats, extended
■ CSPU-S	One open storage (behind push open lid) in upper part of dash panel center section	□ FMAT-RUB	Rubber floor mats
□ ADFS	Two extra DIN slots in front shelf - can be fitted with card or drawer available as an accessory	□ FMAT-T2E	
■ BUPALARM	Reverse alarm	□ FMAT-TX2	Textile and rubber floor mats
□ RTOLL-PK	Road toll PREPARATION kit for trucks operating with "Toll Collect" in Germany	□ LBK-RES	Foldable rest bunk
□ LOADIND	Load indicator with central dashboard display	□ LBK70	Lower bunk 700 x2000 mm, fixed
□ REMC-MF	Multi-functio wireless remote control	■ ULBK	Without lower bunk
□ FIREXT3S	3kg fire extinguisher mounted on seat base	□ MATL-FI	Firm lower bunk pocket sprung mattress
□ WARNVEST	High visibility warning vest - no sleeves	□ MATL-SF	Lower flexizone mattress - semi-firm, pocket springs up to 100kg - 16 stone
□ AIDKIT	First aid kit	□ MATL-SO	Lower flexizone mattress - soft, pocket springs up to 85kg - 13.5 stone
□ AIDKIT1B	First aid kit	□ OLMAT-BA	35mm mattress overlay protector
□ WARNLAMP	Portable warning lamp	□ OLMAT-PR	50mm premium mattress overlay protector
□ LAMP-IN	Inspection lamp	□ TBK60F	Fixed foldable top bunk 600 x 1900mm
□ BULBKIT	Bulb and fuse kit	□ TBK70F	Fixed foldable top bunk 700 x 1900mm
□ WRITEPAD	Writing pad	□ PH-CAB2	1.8kW Air to air night heater
□ UPHTRI10	Seats: Black embossed textile insert with light grey sides, black vinyl side bolster with blue vinyl side insert. Interior trim: Raven black bunk and curtains & blue textile side walls	□ PH-ENGCA	Engine and cab night heater
■ UPHTRI11	Seats: Light grey embossed textile insert, black raven metallic vinyl bolster with red vinyl side insert. Interior trim: Raven black bunk and curtains & grey vinyl side walls	□ PH-SS	Short stop heater
□ UPHTRI12	Seats: Blue soft textile insert, black vinyl bolster. Interior trim: Raven black bunk and curtains & blue textile side walls	□ SLCP-BAS	Basic sleeper control panel - includes interior light, parking heater, roof hatch and door lock
□ UPHTRI13	Seats: Dark grey leather insert and black leather bolster. Interior trim: Raven black bunk and curtains & grey vinyl side walls	□ SAFE	Safe box for driver's personal items
□ UPHTRI14	Seat: Dark grey leather insert and black leather bolster. Interior trim: Raven black bunk and curtains & blue textile side walls	□ ETSB-F	Storage on engine tunnel - on front top
■ DST-CF4	Driver seat, comfort, suspended, belt in seat	□ ETSB-FR	Storage on engine tunnel - on front top and at rear cab wall
□ DST-CF5	Driver seat, comfort, suspended, belt in seat, electrically heated	□ ETSB-FRS	Storage on engine tunnel - on front top & at rear cab wall & storage recessed into tunnel on right hand side
□ DST-CF6	Driver seat, comfort, suspended, belt in seat, electrically heated, ventilated	□ ETSB-FS	Storage on engine tunnel - on front top and storage recessed into tunnel on right hand side
□ SBD-RED	Red seat belts	□ ETSB-R	Storage on engine tunnel - box at rear cab wall
□ SBPRE-DS	Driver seat belt pretensioner	□ ETSB-RS	Storage on engine tunnel - at rear cab wall and storage recessed into tunnel on right hand side
		□ ETSB-S	Storage on engine tunnel - recessed into tunnel on right hand side
		□ RUS-BAS	Rear cab upper storage 154 litres - 300 mm high
		□ RUS-HIG	Rear cab upper storage 245 litres - 440 mm high
		□ TABLE	Folding and height adjustable table - on lower bunk
		□ REF-ICPK	Fridge: engine tunnel mounted preparation kit
		□ REFR-RUS	Fridge: 28 litre rear upper wall mounted with dividers
		□ MICRO-PK	Preparation kit for microwave oven (wiring)
		□ BOTH-D	One bottle holder under dashboard centre section
		□ COFMA-PK	Coffee maker, preparation kit.
		■ INLI-BAS	Interior white LED lights - basic
		□ INLI-NL	Interior white and red night LED light with no dimmer
		□ INLI-NLD	Interior white and red night LED light with dimmer

■ Standard Equipment

□ Optional Equipment

For more detailed information about cab and powertrain equipment, please refer to separate specification sheets.

For all possible options and combinations of options please consult your Volvo sales contact who can create a specification to match your requirements using the Volvo Sales Support system (VSS).

The factory reserves the right to modify design and change equipment without previous notification. The specification can vary from country to country.

MODEL RANGE

FMX13 8x4 Rigid - High T Ride - N3 Cranked front axle for on road work FM 84F R3HTX

- ARL-FLEX** Two flexible reading lamps (snake lamps)
 - RH-EE** Without roof hatch -Tinted glass emergency exit ONLY
 - RH-ETR** Glass roof & escape hatch - Electrically operated, tinted glass with rear opening
 - RH-MSR** Steel roof & escape hatch - Manually operated with rear opening
 - RH-MTR** Glass roof & escape hatch - Manually operated, tinted glass with rear opening
 - URH** Without roof hatch
 - SWIND-BS** Extra side window on both sides behind "B" pillar
 - SWIND-PS** Rear side window, passenger side
 - VANMIR** Vanity mirror in front shelf
 - AS-FUS** Extra shelf in front upper storage compartments
 - INFOT-PK** Preparation kit for the mounting of a flat screen TV in cab above the driver's door, includes bracket, electrical and speaker connections
- CAB EXTERIOR**
- PAICS-B** Basic cab paint - mirrors, sunvisor, instep and bumper supplied in natural finish - grey
 - GLAS-TIN** Tinted windows.
 - AWIND-RF** Rear window
 - DGLAS-L** Laminated door glass
 - LOCK-MAN** Manual door locking
 - LOCK-MRP** Manual door locking with internal remote control (from driver side) of passenger door
 - LOCK-REM** Central locking with remote control
 - BUMP-HD** Heavy duty front bumper
 - GUARD-EH** Engine guard to protect sump and engine hoses
 - BUGNET** Insect screen in front of radiator
 - CTILT-P-E** Electrically operated hydraulic cab tilt
 - CTILT-P-M** Manually operated hydraulic cab tilt
 - FCABS-A** Front cab suspension - Air
 - FCABS-M** Front cab suspension - Mechanical spring
 - RCABS-A** Rear cab suspension - Air
 - RCABS-M** Rear cab suspension - Mechanical spring
 - MIRCOMFX** Electrically heated and operated -FMX- main and wide-angle mirrors with manually adjusted passenger kerb mirror, to increase direct vision to the side the main mirrors have no cowlings
 - MIRSTDX** Electrically heated -FMX- main and wide-angle mirrors with manually adjusted passenger kerb mirror, to increase direct vision to the side the main mirrors have no cowlings
 - AMIR-F20** Auxiliary front view mirror with a 200mm radius
 - SUNV-H** External smoke grey sunvisor
 - AD-ROOF** Roof air deflector
 - AD-SIDEL** Side air deflector extension panels
 - AD-SIDES** Short cab side air deflector for rigid bodywork
 - HL-BAS2** Halogen H1 head lamps
 - HL-BASIC** Halogen H7 head lamps
 - HL-CLEAN** Head lamp cleaner - washer jets
 - HLP-ST** Headlamp protection
 - HL-ADJ** Headlight adjustment - Switch in cab
 - ASL-RF2** Two Hella H11 70W spotlamps in sign box - only available with the basic headlight and no lower driving lights.
 - ASL-RFPK** Preparation kit for two spotlamps in sign box
 - BEACOA2F** Two front roof mounted amber beacon rotating warning lamps
 - BEACOA2R** Two rear roof mounted (on accessory bracket) amber beacon flashing warning LED lamps
 - BEACON-P** Roof beacon wire preparation
- Standard Equipment Optional Equipment
- BEACONA4** Four roof mounted (2 front/2 rear) amber beacon rotating warning lamps
 - CABPT-R1** Single outlet for roof mounted accessories
 - CABPT-R2** Twin outlets for roof mounted accessories.
 - SPOTP-F** Spotlamp preparation in front, max 280W
 - SPOTP-R** Spotlamp preparation on roof, max 280W
 - SPOTP-RF** Spotlamp preparation on cab roof and in cab front, max 2x280W
 - ROS-IL2** Preparation kit for illuminated roof sign with switch loose in cab, fit after registration
 - CSGN-FMX** "Volvo FMX" headboard logo
 - HORN-F1S** Single tone Jericho air horn chassis mounted
 - HORN-R2S** Two roof mounted air horns
 - ANT-CBR** Roof mounted antenna for CB radio, single aerial
 - ACCB-R-AP** Front, middle & rear roof mounted accessory brackets
 - ACCB-R-F** Front roof mounted accessory bracket
 - ACCB-R-FM** Front & middle roof mounted accessory brackets
 - ACCB-R-FR** Front & rear roof mounted accessory brackets
 - ACCB-R-M** Middle roof mounted accessory bracket
 - ACCB-R-R** Rear roof mounted accessory bracket
 - ACCB-R-RM** Rear & middle roof mounted accessory brackets
 - REFS-TW** White cab conspicuity markings by packed in cab
 - REFS-TY** Yellow cab conspicuity markings by packed in cab
- SUPERSTRUCTURE PREPARATIONS**
- BP-MI02**
 - BP-TI03**
 - SRWL-PK** Wiring preparation for side & rear work/reverse lamps on side of chassis and a three-position switch, maximum 280W
 - SWL-2FW** Two H3 70W white front chassis mounted (LH/RH side) working lamps and a 2-position switch (On/Off)
 - SWL-2RW** Two H3 70W white rear chassis mounted (LH/RH side) working lamps and a 2-position switch (On/Off)
 - SWL-4W** 4 H3 70W white front (2) & rear (2) chassis mtd (LH/RH side) working lamps & 2-pos switch (On/Off)
 - SWL-PK** Wiring preparation for side work/reverse lamps on side of chassis and a three-position switch, maximum 280W
 - WLC-H2A** Two H3/70W working lamps with amber coloured lens high mounted back of cab
 - WLC-H2W** Two H3/70W white working lamps high mounted on the back of cab
 - WLC-PKCH** Preparation kit (cables and switch) for cab mounted chassis working lamp
 - WLC-PKH** Preparation kit, cables and switch for high mounted working lamps back of cab
 - WLC-PKL** Preparation kit, cables and switch for low mounted working lamps back of cab
 - WLC-PKLH** Preparation kit - cables and switch for low and high mounted working lamps back of cab.
 - ECBB-BAS** Body builder electrical centre without body builder module
 - ECBB-HIG** Body builder electrical centre with body builder module
 - BBCHAS1** One 7-pole connector for Body builder interface
 - BBCHAS3** Three 7-pole connectors for Body builder interface
 - BEPR-T2** Body builder electrical software preparation for tipper with remote control
 - EXSTER** External steering control, with VDS and bodybuilder module
 - TD-BAS** Trailer detection WITHOUT LED sensing
 - TD-LED** Trailer detection with LED sensing
 - FRFS-BS** Frame rail free space on both sides to give space for crane legs or other equipment.
 - FBA-BTF** Lower front body attachments for torsionally flexible - platform body
 - FBA-BTSF** Lower front body attachments for torsionally semi-flexible body - box or curtainsider

For more detailed information about cab and powertrain equipment, please refer to separate specification sheets.

For all possible options and combinations of options please consult your Volvo sales contact who can create a specification to match your requirements using the Volvo Sales Support system (VSS).

The factory reserves the right to modify design and change equipment without previous notification. The specification can vary from country to country.

MODEL RANGE

FMX13 8x4 Rigid - High T Ride - N3 Cranked front axle for on road work FM 84F R3HTX

- **HBA-FSFB** Holes for body attachments - flexible/semi-flexible body
- **HBA-SB** Holes for body attachments - stiff body
- **RBA-T2** Lower rear body attachments for helper frame
- **CRANEPK1** Crane plates mounted to frame, for cranes up to 10 tonne metre capacity
- **CRANEPK2** Crane plates mounted to frame, for cranes up to 20 tonne metre capacity
- **CRANEPK4** Crane plates mounted to frame, for cranes up to 40 tonne metre capacity
- **AUXL-SPK** Electrical preparation kit - wiring and switch for snow plough lights
- **TAILPRE2** Tail lift preparation kit, wireless remote operation
- **TAILPREP** Taillift preparation kit - cab switch and warning in driver display
- **AESW2** Two Body builder bistable electrical switches (marked AUX1 / AUX2)
- **AESW2PK** 2 Body builder bistable el.switches (marked AUX1/AUX2) and prep. for 4 more switches
- **AUXSW-4** Wiring for 4 extra switches (from Body builder electrical centre to switch positions)

DELIVERY SERVICES

- **TGW-4GWL** GSM/GPRS/4G modem, LTE & WLAN for telematics gateway
- **FMS-PK** Fleet Management System gateway

VOLVO

Volvo Truck Corporation
volvotrucks.com