

MODEL RANGE

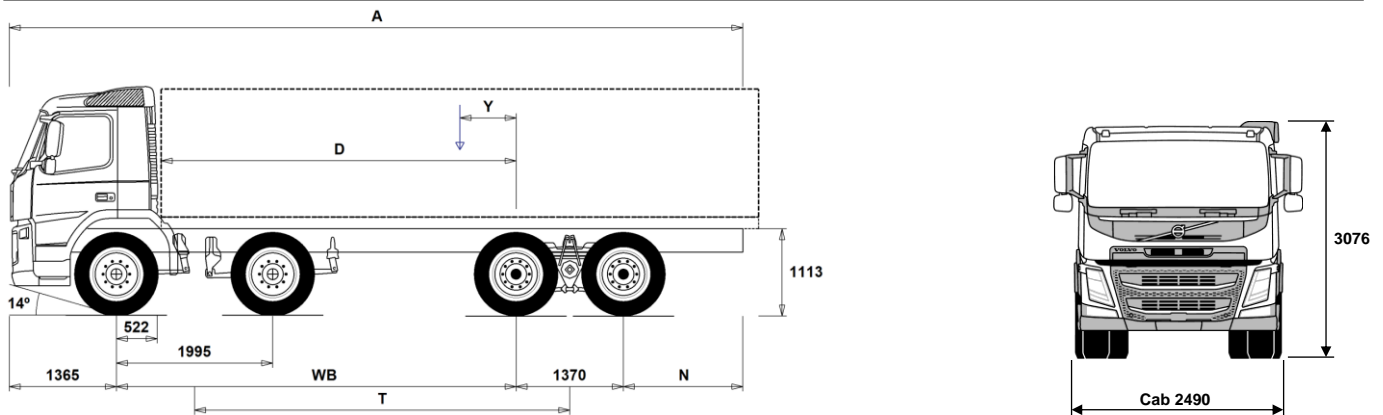

Volvo Trucks. Driving Progress

FM 13 8x4 Rigid - High T Ride - N3 Cranked front axle for on road work FM 84F R3HT



Chassis Dimensions [mm]

WB Wheelbase	5100	5600
A Overall Chassis Length	10660	11410
D Center of rear axle to front of body	4528	5028
N Rear Overhang (Min.)	1225	1225
N Rear Overhang (Max.)	2825	3075
T Theoretical Wheelbase	4788	5288
Y Center of Gravity for Payload (Min.)	739	901
Y Center of Gravity for Payload (Max.)	1379	1610

Chassis Weights [kg]

Front Axles	6330	6295
Rear Bogie	3245	3355
Kerb Weight	9575	9650
Payload (including body, driver, fuel, etc.)	22425	22350

Turning Diameter [mm]

Turning Circle Diameter Kerb to Kerb	20600	22200
Turning Circle Diameter Wall to Wall	22000	23700

Plated Weights [kg]

	Plated	Design
Gross Vehicle Weight	32000	42000
Gross Combination Weight	44000	44000
Front Axles	16000	16000
Rear Bogie	19000	26000

Important Notes

Chassis Dimensions

Cab Height: +416 mm for CAB-HSLP, -169 mm for CAB-LSLP.
Front Axle to Back of Cab: +424 mm for CAB-HSLP and CAB-SLP, +418 mm for CAB-LSLP.

D-measure includes a front clearance of 50 mm and for rigid trucks also a subframe of 100 mm.

Height can vary ± 20 mm for leaf and ± 10 mm for air suspension.

All dimensions are for unladen chassis and any tag axles down.

Rear overhang used for vehicle weight calculation is the maximum rear overhang (N Max.) for selected wheelbase.

Weight and dimensions are based upon the following tyres:

Front Axle Tyres:	315/80R22.5
Drive Axle Tyres:	315/80R22.5

Chassis weight includes oil, water, AdBlue, 0 litres fuel and without driver. Kerb weight can vary $\pm 3\%$.

Turning diameters are theoretically calculated.

Legal weights can differ from country to country.

For more detailed weight information, including optional equipment weights, ask your Volvo sales contact to enter your specification into the Volvo Weight Information system (WIS).

Do NOT use this drawing for bodybuilding. Refer to Volvo Bodybuilder Instructions and chassis assembly drawing FM84FR3HT.

MODEL RANGE

FM 13 8x4 Rigid - High T Ride - N3 Cranked front axle for on road work FM 84F R3HT

TRUCK USE

- PTO-HT16** High torque power take-off up to 1600Nm
- PTO-HT20** High torque power take-off up to 2000Nm
- RC-ROUGH** Operating class on/off road
- RC-VROUG** Very rough road conditions
- TIPP-PRE** Tipper vehicle preparation
- UNIFORM** Basic platform vehicle

CORE COMPONENTS

- CHH-HIGH** Chassis height high - N3 "On Road" chassis - For a specific loading height always check the unique BEP chassis drawing
- RADD-TR1** T-ride 1 rear two spring bogie suspension, 75mm wide springs
- RADD-TR2** T-ride 3 rear two spring bogie suspension, reinforced
- FM-DAY** Day cab - with steel safety cage design
Designed and built to Swedish impact and ECE R29 regulations
- FM-HSLP** Globetrotter cab - with steel safety cage design
Designed and built to Swedish impact and ECE R29 regulations
- FM-LSLP** Low sleeper cab - with steel safety cage design
Designed and built to Swedish impact and ECE R29 regulations
- FM-SLP** Sleeper cab - with steel safety cage design
Designed and built to Swedish impact and ECE R29 regulations
- EU6SCR** Emission level - Euro 6
- D13 420S** D13K420 12.8 litre engine developing 420hp at 14-1800rpm.
Peak torque 2100Nm at 860 -1400rpm.
- D13 460S** D13K460 12.8 litre engine developing 460hp at 14-1800rpm.
Peak torque 2300Nm at 900-1400rpm.
- D13 500S** D13K500 12.8l engine developing 500hp at 14-1800rpm.
Peak torque 2500Nm at 1000-1400rpm.
- D13K420** D13K420 - 420hp engine
- D13K460** D13K460 - 460hp engine
- D13K500** D13K500 - 500hp engine
- EBR-EPG** Exhaust brake controlled by steering column switch
- EBR-EPGC** Exhaust pressure governor for I shift gearbox
- EBR-VEB+** Volvo engine brake + and exhaust pressure governor, enhanced performance from additional exhaust rocker control. Retardation 375kW
- AT2612F** AT2612F 12-speed "I-shift" automated mechanical gearbox suitable for gross train weights up to 60tonne only refer to sales engineering when used in conjunction with a PTO
- ATO2612F** ATO2612F 12-speed "I-shift" overdrive automated mechanical gearbox suitable for gross train weights up to 60tonne refer to sales engineering when used in conjunction with a PTO
- PT2606** Powertronic automatic 6-speed gearbox, max. engine torque 2600 Nm, max. permitted GCW 130000 kg
- SPO2812** SPO2812 - 12 speed I-shift Dual Clutch automated mechanical gearbox GCW 60tonne
- RTH2610F** RTH2610F hub reduction tandem 26tonne drive axles, GCW 100 tonnes with differential and cross locks*
* Cross locks replaced by a dog clutch if tandem axle lift is specified
- RTH3210F** RTH3210F hub reduction tandem 32 tonne drive axles, GCW 100 tonnes with differential and cross locks*
* Cross locks replaced by a dog clutch if tandem axle lift is specified
- RTH3312** RTH3312 hub reduction tandem 33tonne drive axles, GCW 120 tonnes with differential and cross locks*
* Cross locks replaced by a dog clutch if tandem axle lift is specified
- RTS2370A** RTS2370A single reduction tandem 23tonne drive axles with differential and cross locks* - design GCW 70tonnes.
* Cross locks replaced by a dog clutch if tandem axle lift is specified.

Standard Equipment

Optional Equipment

For more detailed information about cab and powertrain equipment, please refer to separate specification sheets.

For all possible options and combinations of options please consult your Volvo sales contact who can create a specification to match your requirements using the Volvo Sales Support system (VSS).

The factory reserves the right to modify design and change equipment without previous notification. The specification can vary from country to country.

PACKAGES

- DRIVEFM** Cab Package: Drive
- DRIVEFM+** Cab Package: Drive +
- BEDFM** One bed resting package
- AUDHIG** High Power Audio system: RDS radio with CD player - also playing MP3/WMA files from CD -, with integrated bluetooth phone and USB/Line inputs. FM/AM antenna, speakers in dashboard, doors, and sleeping compartment.
- MEDIA** AM/FM Bluetooth radio without CD player. USB and Aux line inputs. Speakers in dashboard, doors, and sleeping compartment. 7" touch screen with personal apps.
- MEDIADF** AM/FM Bluetooth radio without CD player. USB and Aux line inputs. Speakers in dashboard, doors, and sleeping compartment. 7" touch screen with personal and professional apps. Dynafleet vehicle on-board data display with office internet support.
- MEDIANAV** AM/FM Bluetooth radio without CD player. USB and Aux line inputs. Speakers in dashboard, doors, and sleeping compartment. 7" touch screen with personal and professional apps. Truck based satellite navigation (live updates not included)
- MEDIANDF** AM/FM Bluetooth radio without CD player. USB and Aux line inputs. Speakers in dashboard, doors, and sleeping compartment. 7" touch screen with personal and professional apps. Truck based satellite navigation (live updates not included) Dynafleet vehicle on-board data display with office internet support.
- VISI15** Visibility Package
- RCHAPAC1** Chassis Package Rigid

CHASSIS

- FST-PAR** Front suspension type - 2 leaf parabolic springs
- FST-PAR3** Front suspension type - 3 leaf parabolic springs
- FAL16.0** Front axles design capacity 16 tonnes - 2 x 8.0 tonne front axles
- FAL18.0** Front axles design capacity 18 tonnes - 2 x 9 tonne front axles - check tyre load index
- FAL20.0** Front axles design capacity 20 tonnes - 2 x 10.0 tonne front axles only available with front air suspension.
- FSM-LUB** Lubricated rear shackles on front suspension pins and bushings
- FSTAB** Front anti-roll bar
- FSTAB2** Front anti-roll bar medium stiffness
- FSTAB3** Front stiff anti-roll bar
- RAL23** Rear bogie design capacity 23 tonnes
- RAL26** Rear bogie design capacity 26 tonnes
- RAL32** Rear bogie design capacity 32 tonnes
- RSTAB1** Rear anti-roll bar
- RSAP2** Heavy duty rear suspension application (with reinforcements)
- ACTST-TO** Volvo Dynamic Steering (VDS) with with extra electronic pump and torque overlay
- ASFE-BAS** Active steering feature - Basic - Volvo Dynamic Steering only
- ASFE-PS** Active steering feature - Volvo Dynamic Steering with personal settings
- PSS-DUAL** Dual power steering system
- PSP-VAR** Power steering pump with variable displacement
- EBS-MED** EBS medium package including "hill" hold function
- AUXPARK** Additional spring parking brakes
- RST-MUL** Rear Suspension, Multi-leaf springs
- RST-PAR1** Rear Suspension, Parabolic springs
- RST-PAR5** Rear Suspension, Progressive parabolic springs

MODEL RANGE

FM 13 8x4 Rigid - High T Ride - N3 Cranked front axle for on road work FM 84F R3HT

- **FBREG-E** Front regulating brake valve, EBS
- **FRAME300** Frame rail section external height 300 mm
- **FST8080** Frame thickness - web and flange 8.0mm
- **FIL-EEEB** Inner liner from end of engine to end of bogie
- **FIL-EEEF** Inner liner from end of engine to end of frame
- **FIL-FBEB** Inner liner over rear bogie
- **FIL-FBEF** Inner liner from front of bogie to end of frame
- **FIL-TXEB** Inner liner from gearbox member to end of bogie
- **FIL-TXEF** Inner liner from gearbox member to end of frame
- **BBOX-L** Battery box located on left hand side
- **2BAT210B** 2 x 210 Ah capacity Gel batteries
- **2BATT170** 2 x 170 Ah capacity batteries
- **2BATT225** 2 x 225 Ah capacity batteries
- **BATTAMP** Battery voltage and ampere gauge
- **BATTIND** Battery charge indication
- **ADR2** ADR package for transportation of dangerous goods on road (Note does NOT include safe loading pass package if required this is quoted seperately)
- **MSWI-A** Main switch - ADR switch circuit shut down
- **MSWI-C** Main switch - Chassis mounted toggle switch by battery box
- **MSWI-R** Main switch - Key fob operated remote controlled
- **UR-FUEL** Without right fuel tank
Min volume 255l
Max volume 810l
- **UL-FUEL** Without left fuel tank
Min volume 160l
Max volume 450l
- **ADTP-L** AdBlue tank on left hand side
- **ADTP-LF** AdBlue tank on left hand side at the front
- **ADTP-R** AdBlue tank on right hand side
- **ADB032** AdBlue tank usable volume 32 litres
- **ADB048** AdBlue tank usable volume 48 litres
- **ADB064** AdBlue tank usable volume 64 litres
- **FCAP-L** Locking fuel filler cap
- **FUFF-AS** Fuel filling anti-spillage device
- **FUFF-ATS** Fuel filling anti-theft and anti-spillage devices
- **ESH-LEFT** Horizontal silencer, left exhaust outlet
- **ESH-REAR** Horizontal silencer, rear exhaust outlet
- **ESH-RIGH** Horizontal silencer, right exhaust outlet
- **ESH-VERT** Horizontal silencer, vertical exhaust outlet
- **ESHVERT** Horizontal chassis mounted diesel particulate filter and vertical SCR silencer behind cab
- **EXST-SSP** Stainless steel exhaust stack - NOT polished
- **EXST-ST** Steel exhaust stack
- **WHC-FIX2** Two fixed wheel chocks
- **WHC-FOL2** Two foldable wheel chocks
- **WHCP-F** Wheel chock(s) stored in the front part of the vehicle
- **WHCP-R** Wheel chock(s) stored in the rear part of the vehicle
- **WHCP-T** Transport mounted wheel chock(s) stored in cab outer luggage locker
- **TB-L80** Toolbox 800 mm, left side
- **TB-R80** Toolbox 800 mm, right side
- **SUP-BAS** EC approved chassis side guards
- **SUP-LOW** EC approved low chassis side guards
- **CHAIN-S** Snow chains
- **HOOK-SC** Snow chain hooks
- **TOWF-NO1** One front towing device
- **TOWF-NO2** Two front towing devices
- **TOWMBRH** Towing member, high mounted in centre of frame, D = 190
- **TOWMBRL1** Towing member, low mounted under the frame
- **TOWMBRM** Towing member, medium mounted in line with frame lower
- **RFEC-S** Rear frame end, straight cut for regular platform applications
- **RFEC-U** Rear frame end, upper cut for tipper applications.
- **C-RI4040** Towing coupling, Ringfeder 4040 G-150
- **C-RI5055** Towing coupling, Ringfeder 5055 G-150
- **C-RO400G** Towing coupling, Rockinger 400 G-150 for 40mm eyes
- **C-RO50** Rockinger RO 50 50mm for centre axle trailer
- **TOWR-ONE** Towing hitch attached to rear crossmember
- **TREL-PK** Trailer electrical preparation kit - chassis/cab wiring
- **TREL14** Single 14 pole electrical trailer connector
- **TREL15** Single 15 pole electrical trailer connector - ADR certified
- **TREL7** 7 pole - 24N trailer electrical suzie
- **TREL7-7** 24N and 24S trailer electrical suzies
- **TBC-DUO** Duomatic type air line connectors
- **TBC-EC** Palm coupling type air line connectors
- **TRBR-HCF** Full pressure hand controlled trailer brake
- **TRBR-STA** Stationary trailer brake control
- **TRB-STRE** Stretch Brake - Automatic low speed trailer brake activation to avoid jack-knifing and improve steerability
- **RUP-FOSL** Folding & sliding EC approved aluminium rear underrun
- **FFEND-B** Standard mounted mud wings on second front axle
- **FFEND-T** Transport mounted mud wings on second front axle
- **RFEND-B** Three piece EC approved rear mud wings and spray flaps
- **RFEND-T** Rear mud wings, transport mounted
- **RFH-BAS** Basic rear wing height
- **RFH-HIG** High rear wing height - higher wing tops
- **RFH-LOW** Lower rear wing height - shallower wing tops
- **ATANK-AL** Aluminium air tanks
- **ATANK-ST** Steel air tanks
- **TL-LED** Rear lights LED
- **BLIGHT-E** Emergency brake light

WHEELS & TYRES

- **RT-AL** Alcoa brushed aluminium rims with standard holes for long stud fixing on all axles
- **RT-ALDP** Alcoa Dura-Bright EVO aluminium rims with standard holes long stud fixing on all axles, requires cleaning with a ph neutral solution - washing up liquid.
- **RT-ALDPD** Alcoa Dura-Bright EVO aluminium rims with countersunk holes for short stud fixing on all axles, requires cleaning with a ph neutral solution - washing up liquid.
- **RT-ALDU** Alcoa brushed aluminium rims with countersunk holes for short stud fixing on all axles
- **RT-SPOKE** Spoke rims on all axles
- **RT-STEEL** Steel rims on all axles
- **WCAP** Aerodynamic hub caps
- **SPWT-D** Spare wheel & tyre with rear tyre pattern
- **SPWT-F** Spare wheel & tyre with front tyre pattern
- **SWCP-LF** Spare wheel carrier on left side of chassis ahead of rear axle
- **SWCP-T** Spare wheel supplied temporarily strapped to chassis
- **SWCP-TP** Temporary spare wheel carrier on top of chassis frame
- **JACK-12T** 12 tonne bottle jack
- **JACK-15T** 15 tonne bottle jack
- **JACK-20T** 20 tonne bottle jack
- **TOOL-BAS** Basic Toolkit
- **TOOLKIT** Complete tool kit
- **INFLAHOS** Tyre inflation hose
- **GAUGE-TP** Tyre pressure gauge

DRIVELINE EQUIPMENT

- **ASO-C** Crawler gear -
Ratio direct top gearbox 19:1
Ratio Overdrive gearbox 17:1

■ Standard Equipment □ Optional Equipment

For more detailed information about cab and powertrain equipment, please refer to separate specification sheets.

For all possible options and combinations of options please consult your Volvo sales contact who can create a specification to match your requirements using the Volvo Sales Support system (VSS).

The factory reserves the right to modify design and change equipment without previous notification. The specification can vary from country to country.

MODEL RANGE

FM 13 8x4 Rigid - High T Ride - N3 Cranked front axle for on road work FM 84F R3HT

- | | |
|---|---|
| <ul style="list-style-type: none"> <input type="checkbox"/> ASO-ULC Ultra low crawler and crawler gear - Ratios direct top gearbox 32:1 and 19:1 Ratios Overdrive box 32:1 and 17:1 <input type="checkbox"/> TRAP-HD Reinforced gearbox application <input type="checkbox"/> TP-CON Construction Package <input type="checkbox"/> TP-DIST Distribution Package <input type="checkbox"/> TP-HD I-shift software - Heavy duty for high GCW Special conditions apply consult Sales Engineering <input type="checkbox"/> TP-LONG Long Haul Package <input type="checkbox"/> AMSO-AUT Enhanced I-shift software with manual shift available in auto mode and kickdown facility on accelerator pedal <input type="checkbox"/> AVO-ENH Enhanced software for off road driveability and starting <input type="checkbox"/> APF-ENH I-shift enhanced PTO functions <input type="checkbox"/> RET-TH Gearbox mounted retarder <input type="checkbox"/> RET-TPT Hydraulic Retarder for Powertronic gearbox <input type="checkbox"/> TC-HWO Automatic gearbox oil cooler - water to oil <input type="checkbox"/> TC-MAOH2 Extra high performance transmission oil cooler - air to oil with front mounted radiator <input type="checkbox"/> TC-MWO Basic transmission oil cooler - water to oil <input type="checkbox"/> 1COMP530 Single cylinder, air compressor, 530 litres per minute <input type="checkbox"/> 2COM1100 Two cylinder, air compressor, 1100 litres per minute <input checked="" type="checkbox"/> 2COMP900 Two cylinder, air compressor, 900 litres per minute <input type="checkbox"/> CLU-AIRC Clutchable air compressor <input checked="" type="checkbox"/> AIRIN-HI Roof mounted air intake behind cab on left hand side <input type="checkbox"/> AIRIN-LO Low level air intake behind cab on left hand side <input type="checkbox"/> ACL1ST-S Two stage air filter <input checked="" type="checkbox"/> 24AL110B 110 amp alternator <input type="checkbox"/> 24AL120B 120 amp alternator <input type="checkbox"/> 24AL150B 150 amp alternator <input checked="" type="checkbox"/> CCV-C Closed crankcase engine ventilation <input type="checkbox"/> CCV-O Open crankcase engine breather <input type="checkbox"/> CCV-OX Closed crankcase ventilation for cold markets <input checked="" type="checkbox"/> PRIM-EL Electrical priming pump <input type="checkbox"/> PRIM-MAN Manual priming pump <input type="checkbox"/> FUEQ-EH Fuel line electric heater <input type="checkbox"/> AF-R Hot fuel recirculation heated fuel filter <input type="checkbox"/> FUEFE2LW Large engine mounted dual fuel filter with water separator <input checked="" type="checkbox"/> FUEFE2SW Small engine mounted dual fuel filter with water separator <input type="checkbox"/> EST-AID Air inlet manifold starting heater element <input type="checkbox"/> 220EBH15 220V/1.5Kw electric engine block heater <input type="checkbox"/> PTER-100 Rear engine mounted power-take-off with DIN 100 / ISO 7646 flange <input type="checkbox"/> PTER-DIN Rear engine mounted PTO with DIN5462 (female) splined shaft for a close coupled pump. Models with 3 steering axles will use this to drive the steering pump (AUXPSP) <input type="checkbox"/> PTER1400 Rear engine mounted power-take-off with SAE 1410 flange <input type="checkbox"/> HPE-F101 Parker F1-101, engine mounted, fixed displacement, single flow, engine mounted hydraulic pump <input type="checkbox"/> HPE-F41 Parker F1-41, engine mounted, fixed displacement, single flow, engine mounted hydraulic pump <input type="checkbox"/> HPE-F51 Parker F1-51, engine mounted, fixed displacement, single flow, engine mounted hydraulic pump <input type="checkbox"/> HPE-F61 Parker F1-61, engine mounted, fixed displacement, single flow, engine mounted hydraulic pump <input type="checkbox"/> HPE-F81 Parker F1-81, engine mounted, fixed displacement, single flow, engine mounted hydraulic pump <input type="checkbox"/> HPE-T53 Parker F2-53/53, engine mounted, Fixed displacement, Twin flow engine mounted hydraulic pump <input type="checkbox"/> HPE-T70 Parker F2-70/35, engine mounted, Fixed displacement, Twin flow engine mounted hydraulic pump <input type="checkbox"/> HPE-V45 Parker VP1-45, variable displacement, single flow, engine mounted hydraulic pump | <ul style="list-style-type: none"> <input type="checkbox"/> HPE-V75 Parker VP1-75, variable displacement, single flow, engine mounted hydraulic pump <input type="checkbox"/> PTPT-D Powertronic PTO, 1 front/upper DIN connection for plug-in pump (max. 850 Nm) <input type="checkbox"/> PTPT-F Powertronic PTO, 1 front/upper rear facing SAE flange conn. for prop shaft (max.850 Nm) <input type="checkbox"/> PTR-D Gearbox PTO for plug-in pump, 0.71xeng speed <input type="checkbox"/> PTR-DH Gearbox driven high speed PTO for one plug-in hydraulic pump <input type="checkbox"/> PTR-DM Gearbox driven medium speed PTO for one plug-in hydraulic pump <input type="checkbox"/> PTR-F Gearbox driven PTO with rear flange connection <input type="checkbox"/> PTRD-D Gearbox driven HIGH SPEED PTO for two plug-in hydraulic pumps <input type="checkbox"/> PTRD-F PTO with 1 DIN + 1 flange connection rear, manual gearbox <input type="checkbox"/> HPG-F101 Parker F1-101 gearbox mounted, fixed displacement, single flow, hydraulic pump <input type="checkbox"/> HPG-F41 Parker F1-41 gearbox mounted, fixed displacement, single flow, hydraulic pump <input type="checkbox"/> HPG-F51 Parker F1-51 gearbox mounted, fixed displacement, single flow, hydraulic pump <input type="checkbox"/> HPG-F61 Parker F1-61 gearbox mounted, fixed displacement, single flow, hydraulic pump <input type="checkbox"/> HPG-F81 Parker F1-81 gearbox mounted, fixed displacement, single flow, hydraulic pump <input type="checkbox"/> EIDLESD Engine idle shut down <input type="checkbox"/> DTRI-PER Dashboard in darker peregrine greyish brown. Steering wheel grey and door panels in light beige for FH and black for FH16. <input checked="" type="checkbox"/> STWPOS-R RIGHT HAND DRIVE <input type="checkbox"/> STWM-LE Leather steering wheel <input type="checkbox"/> STGW-AD2 Adjustable steering wheel with neck tilt <input checked="" type="checkbox"/> STGW-ADJ Adjustable steering wheel <input checked="" type="checkbox"/> AIRBAG SRS Driver's air bag <input checked="" type="checkbox"/> DRC-AMII DPF Regeneration control switch - for manual and switching off regeneration <input checked="" type="checkbox"/> 1DAYDIG2 Continental VDO DTCO 4.0 smart tachograph
This tachograph can ONLY offer remote download if the option of Dynafleet or an FMS gateway has been specified with this order. <input type="checkbox"/> 1DAYDIGP Continental VDO DTCO 3.0 digital tachograph
For vehicles with long lead time - this includes prep kit for the retrofit of DTCO 4.0 tachograph.
For updating to new legal demand for trick registration from 15th June 2019.
This tachograph can ONLY offer remote download if the option of Dynafleet or an FMS gateway has been specified with this order. <input type="checkbox"/> ARSL Additional road speed limit - switch in dashboard <input type="checkbox"/> CRUIS-E Eco cruise control (with eco-roll and I-cruise, controls in steering wheel) <input checked="" type="checkbox"/> CRUISEC Cruise control, standard <input type="checkbox"/> ESP-BAS1 Electronic Stability Control <input type="checkbox"/> ESPC-RO ESP (Electronic Stability Program) functionality control - Reduced / Off <input type="checkbox"/> HWSS-ACB Adaptive cruise control ACC with forward collision warning and AEBS advanced emergency brake system <input type="checkbox"/> HWSS-FCB Forward collision warning with AEBS advanced emergency brake system <input type="checkbox"/> LSS-DW Lane departure-warning system <input type="checkbox"/> LCS Lane change support <input type="checkbox"/> DAS-W Driver Alert Support system <input type="checkbox"/> RSENS-W Rain sensing windscreen wipers |
|---|---|
- Standard Equipment Optional Equipment

For more detailed information about cab and powertrain equipment, please refer to separate specification sheets.

For all possible options and combinations of options please consult your Volvo sales contact who can create a specification to match your requirements using the Volvo Sales Support system (VSS).

The factory reserves the right to modify design and change equipment without previous notification. The specification can vary from country to country.

MODEL RANGE

FM 13 8x4 Rigid - High T Ride - N3 Cranked front axle for on road work FM 84F R3HT

<input type="checkbox"/> CU-ECC	Electrically controlled air conditioning with sun sensor	<input type="checkbox"/> SBD-RED	heated, ventilated
<input type="checkbox"/> CU-ECC2	Electrically controlled air conditioning with sun sensor, mist sensor, air quality sensor and carbon filter	<input type="checkbox"/> SBPRE-DS	Red seat belts
<input checked="" type="checkbox"/> CU-MCC	Climate unit with manual controlled air conditioning	<input type="checkbox"/> SBPRE-DS	Driver seat belt pretensioner
<input checked="" type="checkbox"/> IMMOBIL	Thatcham H2 approved immobiliser	<input checked="" type="checkbox"/> PST-BAS1	Passenger seat - Fixed non suspended fold up with seatbelt mounted in cab
<input type="checkbox"/> ALARM-B	Thatcham H1 approved vehicle alarm - Cab only	<input type="checkbox"/> PST-BENC	Bench passenger seat
<input type="checkbox"/> ALARM-E	Enhanced vehicle alarm - Thatcham H1 approved - Cab plus external sensor for body/trailer	<input type="checkbox"/> PST-CF4	Passenger seat - Comfort suspended with seatbelt mounted in seat
<input type="checkbox"/> ALCOLOCK	Alcolock	<input type="checkbox"/> PST-CF5	Passenger seat - Comfort suspended & heated with seatbelt mounted in seat
<input type="checkbox"/> BUPMON	Back up monitor with built in 7" screen on dash and one colour camera supplied loose for fitment by bodybuilder. Can accommodate up to 4 cameras for TfL Safe Scheme, CLOCS and FORS.	<input type="checkbox"/> PST-STD2	Passenger seat - Fixed non suspended with seatbelt mounted in cab
<input type="checkbox"/> PHONE-PK	Telephone preparation kit (antenna, antenna attachm. cable incl.)	<input type="checkbox"/> PST-STD4	Passenger seat - Standard suspended with seatbelt mounted in cab
<input type="checkbox"/> WLIFT-AD	Electrical window lift, automatic up/down driver side	<input type="checkbox"/> SBPRE-PS	Passenger seat belt pretensioner
<input checked="" type="checkbox"/> WLIFT-EB	Electrical window lift	<input type="checkbox"/> ARM-DBPS	Two armrests on driver seat and one (outer) on passenger seat
<input type="checkbox"/> WLIFT-ME	Mechanical window lift	<input type="checkbox"/> ARMRE-BB	Two armrests on both driver and passenger seat.
<input type="checkbox"/> ISUNS-BS	Side interior sun visor on both sides	<input type="checkbox"/> ARMRE-DB	Two armrests, on driver seat only
<input checked="" type="checkbox"/> ISUNS-DS	Driver's side interior sun visor	<input type="checkbox"/> ARMRE-PB	Two armrests, on passenger seat only
<input checked="" type="checkbox"/> ISUNF-B	Interior front sun visor without mirror	<input type="checkbox"/> ARMRE-PS	Single armrest (next to driver) on passenger seat
<input type="checkbox"/> ISUNF-MD	Interior front sun visor with mirror on driver side	<input type="checkbox"/> ARU-BAS	Vinyl upholstered armrest
<input type="checkbox"/> ISUNF-RE	Electrically operated textile interior sun blind	<input type="checkbox"/> ARU-LEA	Leather upholstered armrest
<input type="checkbox"/> ISUNF-RM	Manually operated textile interior sun blind	<input checked="" type="checkbox"/> FMAT-RUB	Rubber floor mats
<input checked="" type="checkbox"/> CSPU-S	One open storage (behind push open lid) in upper part of dash panel center section	<input type="checkbox"/> FMAT-TX2	Textile and rubber floor mats
<input type="checkbox"/> ADFS	Two extra DIN slots in front shelf - can be fitted with card or drawer available as an accessory	<input type="checkbox"/> LBK-RES	Foldable rest bunk
<input checked="" type="checkbox"/> BUPALARM	Reverse alarm	<input type="checkbox"/> LBK70	Lower bunk 700 x 2000 mm, fixed
<input type="checkbox"/> RTOLL-PK	Road toll PREPARATION kit for trucks operating with "Toll Collect" in Germany	<input checked="" type="checkbox"/> ULBK	Without lower bunk
<input type="checkbox"/> LOADIND	Load indicator with central dashboard display	<input type="checkbox"/> MATL-FI	Firm lower bunk pocket sprung mattress
<input type="checkbox"/> REMC-MF	Multi-functio wireless remote control	<input type="checkbox"/> MATL-SF	Lower flexizone mattress - semi-firm, pocket springs up to 100kg - 16 stone
<input type="checkbox"/> FIREXT3S	3kg fire extinguisher mounted on seat base	<input type="checkbox"/> MATL-SO	Lower flexizone mattress - soft, pocket springs up to 85kg - 13.5 stone
<input type="checkbox"/> WARVEST	High visibility warning vest - no sleeves	<input type="checkbox"/> OLMAT-BA	35mm mattress overlay protector
<input type="checkbox"/> AIDKIT	First aid kit	<input type="checkbox"/> OLMAT-PR	50mm premium mattress overlay protector
<input type="checkbox"/> AIDKIT1B	First aid kit	<input type="checkbox"/> TBK60F	Fixed foldable top bunk 600 x 1900mm
<input type="checkbox"/> WARNLAMP	Portable warning lamp	<input type="checkbox"/> TBK70F	Fixed foldable top bunk 700 x 1900mm
<input type="checkbox"/> LAMP-IN	Inspection lamp	<input type="checkbox"/> PH-CAB2	1.8kW Air to air night heater
<input type="checkbox"/> BULBKIT	Bulb and fuse kit	<input type="checkbox"/> PH-ENGCA	Engine and cab night heater
<input type="checkbox"/> WRITEPAD	Writing pad	<input type="checkbox"/> PH-SS	Short stop heater
<input type="checkbox"/> UPHTRI10	Seats: Black embossed textile insert with light grey sides, black vinyl side bolster with blue vinyl side insert. Interior trim: Raven black bunk and curtains & blue textile side walls	<input type="checkbox"/> SLCP-BAS	Basic sleeper control panel - includes interior light, parking heater, roof hatch and door lock
<input type="checkbox"/> UPHTRI11	Seats: Light grey embossed textile insert, black raven metallic vinyl bolster with red vinyl side insert. Interior trim: Raven black bunk and curtains & grey vinyl side walls	<input type="checkbox"/> SAFE	Safe box for driver's personal items
<input type="checkbox"/> UPHTRI12	Seats: Blue soft textile insert, black vinyl bolster. Interior trim: Raven black bunk and curtains & blue textile side walls	<input type="checkbox"/> ETSB-F	Storage on engine tunnel - on front top
<input type="checkbox"/> UPHTRI13	Seats: Dark grey leather insert and black leather bolster. Interior trim: Raven black bunk and curtains & grey vinyl side walls	<input type="checkbox"/> ETSB-FR	Storage on engine tunnel - on front top and at rear cab wall
<input type="checkbox"/> UPHTRI14	Seat: Dark grey leather insert and black leather bolster. Interior trim: Raven black bunk and curtains & blue textile side walls	<input type="checkbox"/> ETSB-FRS	Storage on engine tunnel - on front top & at rear cab wall & storage recessed into tunnel on right hand side
<input checked="" type="checkbox"/> DST-CF4	Driver seat, comfort, suspended, belt in seat	<input type="checkbox"/> ETSB-FS	Storage on engine tunnel - on front top and storage recessed into tunnel on right hand side
<input type="checkbox"/> DST-CF5	Driver seat, comfort, suspended, belt in seat, electrically heated	<input type="checkbox"/> ETSB-R	Storage on engine tunnel - box at rear cab wall
<input type="checkbox"/> DST-CF6	Driver seat, comfort, suspended, belt in seat, electrically heated, ventilated	<input type="checkbox"/> ETSB-RS	Storage on engine tunnel - at rear cab wall and storage recessed into tunnel on right hand side
		<input type="checkbox"/> ETSB-S	Storage on engine tunnel - recessed into tunnel on right hand side
		<input type="checkbox"/> RUS-BAS	Rear cab upper storage 154 litres - 300 mm high
		<input type="checkbox"/> RUS-HIG	Rear cab upper storage 245 litres - 440 mm high
		<input type="checkbox"/> TABLE	Folding and height adjustable table - on lower bunk
		<input type="checkbox"/> REF-ICPK	Fridge: engine tunnel mounted preparation kit
		<input type="checkbox"/> REFR-RUS	Fridge: 28 litre rear upper wall mounted with dividers
		<input type="checkbox"/> MICRO-PK	Preparation kit for microwave oven (wiring)
		<input type="checkbox"/> BOTH-D	One bottle holder under dashboard centre section
		<input type="checkbox"/> COFMA-PK	Coffee maker, preparation kit.
		<input checked="" type="checkbox"/> INLI-BAS	Interior white LED lights - basic

Standard Equipment

Optional Equipment

For more detailed information about cab and powertrain equipment, please refer to separate specification sheets.

For all possible options and combinations of options please consult your Volvo sales contact who can create a specification to match your requirements using the Volvo Sales Support system (VSS).

The factory reserves the right to modify design and change equipment without previous notification. The specification can vary from country to country.

MODEL RANGE

FM 13 8x4 Rigid - High T Ride - N3 Cranked front axle for on road work FM 84F R3HT

- | | |
|--|---|
| <ul style="list-style-type: none"> <input type="checkbox"/> INLI-NL Interior white and red night LED light with no dimmer <input type="checkbox"/> INLI-NLD Interior white and red night LED light with dimmer <input type="checkbox"/> ARL-FLEX Two flexible reading lamps (snake lamps) <input type="checkbox"/> RH-ECS Glass roof & escape hatch - Electrically operated <input type="checkbox"/> RH-EE Without roof hatch -Tinted glass emergency exit ONLY <input type="checkbox"/> RH-ETR Glass roof & escape hatch - Electrically operated, tinted glass with rear opening <input type="checkbox"/> RH-MSR Steel roof & escape hatch - Manually operated with rear opening <input type="checkbox"/> RH-MTR Glass roof & escape hatch - Manually operated, tinted glass with rear opening <input checked="" type="checkbox"/> URH Without roof hatch <input type="checkbox"/> SWIND-BS Extra side window on both sides behind "B" pillar <input type="checkbox"/> SWIND-PS Rear side window, passenger side <input type="checkbox"/> VANMIR Vanity mirror in front shelf <input type="checkbox"/> AS-FUS Extra shelf in front upper storage compartments <input type="checkbox"/> INFOT-PK Preparation kit for the mounting of a flat screen TV in cab above the driver's door, includes bracket, electrical and speaker connections | <ul style="list-style-type: none"> <input type="checkbox"/> HLP-ST Headlamp protection <input checked="" type="checkbox"/> HL-ADJ Headlight adjustment - Switch in cab <input type="checkbox"/> DRIVL2 Two spot lamps <input checked="" type="checkbox"/> UDRIVL Without auxiliary driving lights <input checked="" type="checkbox"/> FOGL-WC Front fog lights <input type="checkbox"/> CL-STAT Static corner lights <input type="checkbox"/> ASL-RF2 Two Hella H11 70W spotlamps in sign box - only available with the basic headlight and no lower driving lights. <input type="checkbox"/> ASL-RFPK Preparation kit for two spotlamps in sign box <input type="checkbox"/> BEACO2F Two front roof mounted amber beacon rotating warning lamps <input type="checkbox"/> BEACO2R Two rear roof mounted (on accessory bracket) amber beacon flashing warning LED lamps <input type="checkbox"/> BEACON-P Roof beacon wire preparation <input type="checkbox"/> BEACONA4 Four roof mounted (2 front/2 rear) amber beacon rotating warning lamps <input type="checkbox"/> CABPT-R1 Single outlet for roof mounted accessories <input checked="" type="checkbox"/> CABPT-R2 Twin outlets for roof mounted accessories. <input type="checkbox"/> SPOTP-F Spotlamp preparation in front, max 280W <input type="checkbox"/> SPOTP-R Spotlamp preparation on roof, max 280W <input type="checkbox"/> SPOTP-RF Spotlamp preparation on cab roof and in cab front, max 2x280W <input type="checkbox"/> ROS-IL2 Preparation kit for illuminated roof sign with switch loose in cab, fit after registration <input type="checkbox"/> CSGN-GTR "Globetrotter" headboard logo <input checked="" type="checkbox"/> HORN-F1S Single tone Jericho air horn chassis mounted <input type="checkbox"/> HORN-R2S Two roof mounted air horns <input type="checkbox"/> ANT-CBR Roof mounted antenna for CB radio, single aerial <input type="checkbox"/> ACCBR-AP Front, middle & rear roof mounted accessory brackets <input type="checkbox"/> ACCBR-F Front roof mounted accessory bracket <input type="checkbox"/> ACCBR-FM Front & middle roof mounted accessory brackets <input type="checkbox"/> ACCBR-FR Front & rear roof mounted accessory brackets <input type="checkbox"/> ACCBR-M Middle roof mounted accessory bracket <input type="checkbox"/> ACCBR-R Rear roof mounted accessory bracket <input type="checkbox"/> ACCBR-RM Rear & middle roof mounted accessory brackets <input type="checkbox"/> REFS-TW White cab conspicuity markings by packed in cab <input type="checkbox"/> REFS-TY Yellow cab conspicuity markings by packed in cab |
|--|---|
- CAB EXTERIOR**
- | | |
|---|--|
| <ul style="list-style-type: none"> <input type="checkbox"/> PAICS-B Basic cab paint - mirrors, sunvisor, instep and bumper supplied in natural finish - grey <input type="checkbox"/> PAICS-C Complete cab - mirrors, insteps, sunvisor, and bumper finished in cab colour <input checked="" type="checkbox"/> GLAS-TIN Tinted windows. <input type="checkbox"/> AWIND-RF Rear window <input type="checkbox"/> DGLAS-L Laminated door glass <input checked="" type="checkbox"/> LOCK-MAN Manual door locking <input type="checkbox"/> LOCK-MRP Manual door locking with internal remote control (from driver side) of passenger door <input type="checkbox"/> LOCK-REM Central locking with remote control <input type="checkbox"/> BUMP-B Plastic front bumper <input checked="" type="checkbox"/> BUMP-B2 Steel front bumper <input type="checkbox"/> BUMP-SP Front bumper spoiler <input type="checkbox"/> GUARD-EH Engine guard to protect sump and engine hoses <input checked="" type="checkbox"/> BUGNET Insect screen in front of radiator <input type="checkbox"/> CTILT-P-E Electrically operated hydraulic cab tilt <input checked="" type="checkbox"/> CTILT-P-M Manually operated hydraulic cab tilt <input type="checkbox"/> FCABS-A Front cab suspension - Air <input checked="" type="checkbox"/> FCABS-M Front cab suspension - Mechanical spring <input type="checkbox"/> RCABS-A Rear cab suspension - Air <input checked="" type="checkbox"/> RCABS-M Rear cab suspension - Mechanical spring <input type="checkbox"/> MIRCOMF2 Electrically heated and operated FMX style main and wide-angle mirror on both sides, with manual passenger kerb mirror. To increase direct vision to the side the main mirrors have no cowlings <input type="checkbox"/> MIRCOMFM Electrically heated and operated main with manual wide-angle mirror - both sides - and passenger kerb mirror <input type="checkbox"/> MIRSTD2 Electrically heated - FMX - main with wide angle mirror on both sides and kerb view mirror on passenger side, to increase direct vision to the side the main mirrors have no cowlings <input checked="" type="checkbox"/> MIRSTDFM Electrically heated main mirror with wide angle mirror on both sides and kerb view mirror on passenger side <input checked="" type="checkbox"/> AMIR-F20 Auxiliary front view mirror with a 200mm radius <input type="checkbox"/> SUNV-H External smoke grey sunvisor <input type="checkbox"/> AD-ROOF Roof air deflector <input type="checkbox"/> AD-SIDEL Side air deflector extension panels <input type="checkbox"/> AD-SIDES Short cab side air deflector for rigid bodywork <input checked="" type="checkbox"/> HL-BASIC Halogen H7 head lamps <input type="checkbox"/> HL-CLEAN Head lamp cleaner - washer jets | <ul style="list-style-type: none"> <input type="checkbox"/> BP-MI02 <input type="checkbox"/> BP-TI03 <input type="checkbox"/> SRWL-PK Wiring preparation for side & rear work/reverse lamps on side of chassis and a three-position switch, maximum 280W <input type="checkbox"/> SWL-2FW Two H3 70W white front chassis mounted (LH/RH side) working lamps and a 2-position switch (On/Off) <input type="checkbox"/> SWL-2RW Two H3 70W white rear chassis mounted (LH/RH side) working lamps and a 2-position switch (On/Off) <input type="checkbox"/> SWL-4W 4 H3 70W white front (2) & rear (2) chassis mtd (LH/RH side) working lamps & 2-pos switch (On/Off) <input type="checkbox"/> SWL-PK Wiring preparation for side work/reverse lamps on side of chassis and a three-position switch, maximum 280W <input type="checkbox"/> WLC-H2A Two H3/70W working lamps with amber coloured lens high mounted back of cab <input type="checkbox"/> WLC-H2W Two H3/70W white working lamps high mounted on the back of cab <input type="checkbox"/> WLC-PKCH Preparation kit (cables and switch) for cab mounted chassis working lamp <input type="checkbox"/> WLC-PKH Preparation kit, cables and switch for high mounted working lamps back of cab <input type="checkbox"/> WLC-PKL Preparation kit, cables and switch for low mounted working lamps back of cab <input type="checkbox"/> WLC-PKLH Preparation kit - cables and switch for low and high mounted working lamps back of cab. <input type="checkbox"/> ECBB-BAS Body builder electrical centre without body builder module <input checked="" type="checkbox"/> ECBB-HIG Body builder electrical centre with body builder module |
|---|--|

Standard Equipment Optional Equipment

For more detailed information about cab and powertrain equipment, please refer to separate specification sheets.

For all possible options and combinations of options please consult your Volvo sales contact who can create a specification to match your requirements using the Volvo Sales Support system (VSS).

The factory reserves the right to modify design and change equipment without previous notification. The specification can vary from country to country.

MODEL RANGE

FM 13 8x4 Rigid - High T Ride - N3 Cranked front axle for on road work FM 84F R3HT

- BBCHAS1** One 7-pole connector for Body builder interface
- BBCHAS3** Three 7-pole connectors for Body builder interface
- BEPR-T2** Body builder electrical software preparation for tipper with remote control
- EXSTER** External steering control, with VDS and bodybuilder module
- TD-BAS** Trailer detection WITHOUT LED sensing
- TD-LED** Trailer detection with LED sensing
- FRFS-BS** Frame rail free space on both sides to give space for crane legs or other equipment.
- FBA-BTF** Lower front body attachments for torsionally flexible - platform body
- FBA-BTSF** Lower front body attachments for torsionally semi-flexible body - box or curtainsider
- HBA-FSFB** Holes for body attachments - flexible/semi-flexible body
- HBA-SB** Holes for body attachments - stiff body
- RBA-T2** Lower rear body attachments for helper frame
- CRANEPK1** Crane plates mounted to frame, for cranes up to 10 tonne metre capacity
- CRANEPK2** Crane plates mounted to frame, for cranes up to 20 tonne metre capacity
- CRANEPK4** Crane plates mounted to frame, for cranes up to 40 tonne metre capacity
- AUXL-SPK** Electrical preparation kit - wiring and switch for snow plough lights
- TAILPRE2** Tail lift preparation kit, wireless remote operation
- TAILPREP** Taillift preparation kit - cab switch and warning in driver display
- AESW2** Two Body builder bistable electrical switches (marked AUX1 / AUX2)
- AESW2PK** 2 Body builder bistable el.switches (marked AUX1/AUX2) and prep. for 4 more switches
- AUXSW-4** Wiring for 4 extra switches (from Body builder electrical centre to switch positions)

DELIVERY SERVICES

- TGW-4GWL** GSM/GPRS/4G modem, LTE & WLAN for telematics gateway
- FMS-PK** Fleet Management System gateway

VOLVO

Volvo Truck Corporation
volvotrucks.com