

# MODEL RANGE

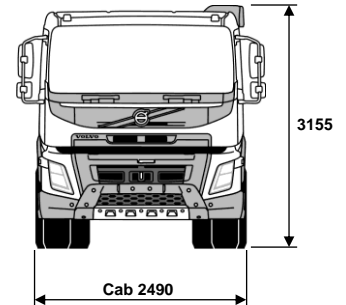

Volvo Trucks. Driving Progress

FMX D13 84 Rigid X-high T-ride FM 84F R3CTX

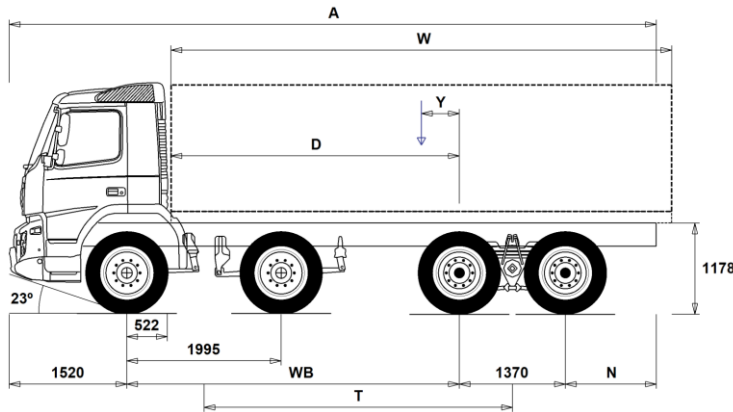

## Chassis Dimensions [mm]

WB Wheelbase	4300	4350	4600	4900	5100	5600
A Overall Chassis Length	8365	8415	8665	8965	9165	9665
D Center of rear axle to front of body	3728	3778	4028	4328	4528	5028
N Rear Overhang (Min.)	825	825	825	825	825	825
N Rear Overhang (Max.)	1175	1175	1175	1175	1175	1175
T Theoretical Wheelbase	3988	4038	4288	4588	4788	5288
Y Center of Gravity for Payload (Min.)	453	468	544	636	697	849
Y Center of Gravity for Payload (Max.)	453	468	544	636	697	849
W Body Length (Min.)	6549	6619	6966	7383	7661	8357
W Body Length (Max.)	6549	6619	6966	7383	7661	8357

## Chassis Weights [kg]

Front Axles	6740	6735	6715	6685	6675	6645
Rear Bogie	2825	2840	2915	2975	3030	3120
Kerb Weight	9565	9575	9630	9660	9705	9765
Payload (including body, driver, fuel, etc.)	32435	32425	32370	32340	32295	32235

## Turning Diameter [mm]

Turning Circle Diameter Kerb to Kerb	18100	18200	19000	20000	20600	22200
Turning Circle Diameter Wall to Wall	19500	19700	20500	21400	22100	23700

## Plated Weights [kg]

Gross Vehicle Weight	42000
Gross Combination Weight	50000
Front Axles	16000
Rear Bogie	26000

## Design

## Important Notes

### Chassis Dimensions

Cab Height: +416 mm for CAB-HSLP.  
 Front Axle to Back of Cab: +424 mm for CAB-HSLP and CAB-SLP.  
 D-measure includes a front clearance of 50 mm and for rigid trucks also a subframe of 100 mm.  
 Height can vary  $\pm 20$  mm for leaf and  $\pm 10$  mm for air suspension.  
 All dimensions are for unladen chassis and any tag axles down.  
 Rear overhang used for vehicle weight calculation is the maximum rear overhang (N Max.) for selected wheelbase.

Weight and dimensions are based upon the following tyres:

Front Axle Tyres:	315/80R22.5
Drive Axle Tyres:	315/80R22.5

**Chassis weight includes oil, water, AdBlue, 0 litres fuel and without driver. Kerb weight can vary  $\pm 3\%$ .**

Turning diameters are theoretically calculated.

Legal weights can differ from country to country.

For more detailed weight information, including optional equipment weights, ask your Volvo sales contact to enter your specification into the Volvo Weight Information system (WIS).

Do NOT use this drawing for bodybuilding. Refer to Volvo Bodybuilder Instructions and chassis assembly drawing FM84FR3CTX.

# MODEL RANGE

FMX D13 84 Rigid X-high T-ride FM 84F R3CTX

## Transport operation

- PTO-HT16** High torque Power take-off 1600Nm
- PTO-HT20** High torque Power take-off 2000Nm
- RC-ROUGH** Rough road conditions.
  - Less than 95% of the driven distance on well maintained or less maintained surfaced roads.
  - and / or
  - In total not more than 5% of the driven distance on:
    - Very badly maintained surfaced roads.
    - Hard packed sand or gravel surface of very bad quality.
    - Washboards.
    - Soft unpaved surface.
    - Off-road.
- RC-VROUG** Trucks built for very rough road conditions are optimised for:
  - More than 5% of the driven distance on:
    - Very badly maintained surfaced roads.
    - Hard packed sand or gravel surface of very bad quality.
    - Soft unpaved surface.
    - Off road.
  - Occasional driving in severe off-road conditions.
- TIPP-PRE** Tipper vehicle preparation

## Core components

- CHH-XHIG** Chassis height extra high - approx. 1030 mm above ground level
- RADD-TR1** Rear leaf suspension, 2 axles - 2 driven (Max. technical bogie load 26 tonnes)
- RADD-TR2** Rear leaf suspension, 2 axles - 2 driven (Max. technical boogie load 32 tonnes)
- FMX-DAY** FMX Day cab
- FMX-HSLP** FMX Globetrotter sleeper cab
- FMX-SLP** FMX Sleeper cab
- EU6SCR** Euro 6 emission level with Selective Catalytic Reduction (SCR), particulate filter and Exhaust Gas Recirculation (EGR)
- D13 420S** Diesel engine with Turbo-S, 12.8 litre Euro 6 SCR + EGR (Diesel Particulate Filter), 420 hp, 2100 Nm
- D13 460S** Diesel engine with Turbo-S, 12.8 litre Euro 6 SCR + EGR (Diesel Particulate Filter), 460 hp, 2300 Nm
- D13 500S** Diesel engine with Turbo-S, 12.8 litre Euro 6 SCR + EGR (Diesel Particulate Filter), 500 hp, 2500 Nm
- D13 540S** Diesel engine Turbo-S, 12.8 litre Euro 6 SCR + EGR (Diesel Particulate Filter), 540 hp, 2600 Nm
- D13K420** Diesel engine, 12.8 litre Euro 6 SCR + EGR (Diesel Particulate Filter), 420 hp
- D13K460** Diesel engine, 12.8 litre Euro 6 SCR + EGR (Diesel Particulate Filter), 460 hp
- D13K500** Diesel engine, 12.8 litre Euro 6 SCR + EGR (Diesel Particulate Filter), 500 hp.
- D13K540** Diesel engine, 12.8 litre Euro 6 SCR + EGR (Diesel Particulate Filter), 540 hp
- DIESEL** Diesel fuel
- DIESEL-B** Biodiesel
- EBR-EPG** Engine brake with exhaust pressure governor, EPG
- EBR-EPGC** Volvo engine compression brake with exhaust pressure governor, EPG (for I-shift)
- EBR-VEB** Volvo Engine Brake, VEB (compression brake with exhaust pressure governor, EPG)
- EBR-VEB+** Volvo Engine Brake, VEB+ (high efficiency compression brake with exhaust pressure governor, EPG)
- AT2412F** I-Shift automated mechanical 12-speed gearbox without clutch pedal, max. engine torque 2400 Nm, max. permitted GCW 44000 kg.
- AT2612F** I-Shift automated mechanical 12-speed gearbox without clutch pedal, max. engine torque 2600 Nm, max. permitted GCW 100000 kg.
- ATO2612F** I-Shift automated mechanical 12-speed overdrive gearbox without clutch, max. engine torque 2600 Nm, max. permitted

Standard Equipment

Optional Equipment

For more detailed information about cab and powertrain equipment, please refer to separate specification sheets.

For all possible options and combinations of options please consult your Volvo sales contact who can create a specification to match your requirements using the Volvo Sales Support system (VSS).

The factory reserves the right to modify design and change equipment without previous notification. The specification can vary from country to country.

- PT2606** GCW 100000 kg. Suitable for hub reduction rear axles.
- SPO2812** Powertronic automatic 6-speed gearbox, max. engine torque 2600 Nm, max. permitted GCW 130000 kg
- RTH2610F** Semi power shift dual clutch 12-speed overdrive gearbox, max. engine torque 2800 Nm, max permitted GCW 80 000 kg.
- RTH2610F** Rear hub reduction tandem axles - bogie load 26 tonnes, GCW 100 tonnes, version F
- RTH3210F** Rear hub reduction tandem axles - bogie load 32 tonnes, GCW 100 tonnes, version F
- RTH3312** Rear hub reduction tandem axles - bogie load 33 tonnes, GCW 120 tonnes

## Packages

- EDITION** Exterior Striping/Emblem. Model specific design on FH,FM,FH16 and FMX
- DRIVEFM** Driving package FM
- DRIVEFM+** Driving plus package FM
- BEDFM** Bed resting package FM
- AUDBAS** Audio basic. RDS radio with CD player, FM/AM antenna and speakers in dashboard & doors. Prepared for Dynafleet office internet portal support.
- AUDHIG** High power audio system. RDS radio with CD player (also playing mp3/wma/wav files from CD), FM/AM antenna, speakers in dashboard & doors & sleeping compartment, integrated bluetooth phone and USB/Line inputs. Prepared for Dynafleet office internet portal support.
- MEDIADF** Media package with infotainment. Prepared for both Dynafleet vehicle onboard support and for Dynafleet office internet portal support.
- MEDIANDF** Media package with infotainment and Navigation support and prepared for Dynafleet vehicle onboard support and for Dynafleet office internet portal support.
- ENOPT** Energy optimization package
- ENOPT+** Energy optimization+ package
- OFFRFMXD** Construction package for FMX day cab
- OFFRFMXS** Construction package for FMX sleeper cabs
- RCHAPAC1** Rigid chassis package

## Chassis

- FST-PAR3** 3 leaf front parabolic suspension (stiffer than normal)
- FAL16.0** Front axle load 16.0 tonnes, double front axles
- FAL18.0** Front axle load 18.0 tonnes, double front axles
- FAL20.0** Front axle load 20.0 tonnes, double front axles
- FSTAB** Front stabilizer with normal stiffness
- FSTAB2** Front stabilizer with medium high stiffness
- FSTAB3** Front stiff stabilizer
- RAL23** Rear axles load 23 tonnes
- RAL26** Rear axles load 26 tonnes
- RAL32** Rear axles load 32 tonnes
- RSTAB1** Rear stabilizer with normal stiffness
- RSAP2** Heavy duty rear suspension application (with reinforcements)
- ACTST-TO** Volvo Dynamic Steering (VDS) with extra pump and torque overlay
- ASFE-BAS** Volvo Dynamic Steering feature basic
- ASFE-PS** Volvo Dynamic Steering personal settings
- PSS-DUAL** Dual power steering system
- PSS-SING** Single power steering system
- PSP-VAR** Power steering pump with variable displacement
- EBS-MED** EBS (Electronic Brake System) medium package:
  - ABS (Anti-lock Braking System)
  - Lining Wear Sensing (20 % left)
  - Lining Wear Control (incl. wear on the axle)
  - Brake Blending
  - Drag Torque Control

# MODEL RANGE

FMX D13 84 Rigid X-high T-ride FM 84F R3CTX

<ul style="list-style-type: none"> <li>- Diff Lock Synchronization</li> <li>- Diff lock Control</li> <li>- Brake Temperature Warning</li> <li>- External Brake Demand</li> <li>- Diagnosis Via Truck Electronic System</li> <li>- Traction Control System</li> <li>- Emergency Brake Assistance</li> <li>- Constant Wheel Brake Monitoring</li> <li>- Coupling Force Control</li> <li>- Automatic Parking Brake Activation</li> <li>- Lining Wear Analyses (calc of remaining mileage)</li> <li>- Hill Starting Assistance</li> <li>- EBS status monitoring via Truck Electronic System</li> </ul>	<ul style="list-style-type: none"> <li>■ <b>ADTP-R</b> AdBlue tank on right hand side</li> <li>□ <b>ADB032</b> AdBlue tank usable volume 32 litres</li> <li>□ <b>ADB048</b> AdBlue tank usable volume 48 litres</li> <li>□ <b>ADB064</b> AdBlue tank usable volume 64 litres</li> <li>■ <b>FCAP-L</b> Lockable diesel and AdBlue tank caps</li> <li>■ <b>FUFF-AS</b> Fuel filling anti-spillage device</li> <li>□ <b>FUFF-ATS</b> Fuel filling anti-theft and anti-spillage devices</li> <li>□ <b>ESH-LEFT</b> Horizontal muffler, left exhaust outlet</li> <li>■ <b>ESH-REAR</b> Horizontal muffler, rear exhaust outlet</li> <li>□ <b>ESH-VERT</b> Horizontal muffler, vertical exhaust outlet on right hand side</li> <li>□ <b>ESHVVERT</b> Horizontal and vertical muffler, vertical exhaust</li> <li>□ <b>ESV-VERT</b> Vertical muffler, vertical exhaust outlet on right hand side</li> <li>□ <b>EXST-SSP</b> Bright polished vertical stainless steel exhaust top pipe</li> <li>□ <b>EXST-ST</b> Aluminized steel vertical exhaust top pipe</li> <li>□ <b>WHC-FIX2</b> Two fixed wheel chocks</li> <li>■ <b>WHC-FOL2</b> 2 foldable wheel chocks</li> <li>□ <b>WHCP-F</b> Wheel chock(s) in the front part of the vehicle. <ul style="list-style-type: none"> <li>- TRACTOR, BBOX-L, Fold, 1/2 w chocks = Top of left side battery box</li> <li>- TRACTOR, BBOX-EF, Fold, 1/2 w chocks = Top of lefts side fuel tank</li> <li>- TRACTOR, BBOX-EF, Fix, 2 w chocks = Left frame front of fuel tank</li> <li>- RIGID, 1 front axle, Fold, 1/2 w chocks = Top of left side battery box</li> <li>- RIGID, 2 front axles, Fold, Frame free space, 2 wc = Top of left side battery box</li> <li>- RIGID, 2 front axles, Fix, W/o frame free space, 2 wc = Left frame behind 1st front wheel</li> </ul> </li> <li>□ <b>WHCP-R</b> Wheel chock(s) in the rear part of the vehicle <ul style="list-style-type: none"> <li>- RIGID, 1 front axle, Fix, 1/2 w chocks = Left frame rear (or front) of rear wheels</li> </ul> </li> <li>□ <b>WHCP-T</b> Transport mounted wheel chock(s) in cab outer luggage compartment</li> <li>□ <b>TB-L80</b> Left toolbox 800 mm length (mounting length 800 mm, real length 730 mm)</li> <li>□ <b>TB-R80</b> Right toolbox 800 mm length (mounting length 800 mm, real length 730 mm)</li> <li>□ <b>CHAIN-S</b> Snow chains</li> <li>■ <b>TOWF-HD1</b> One heavy duty front towing device</li> <li>□ <b>TOWMBRH</b> High mounted towing member, in centre of frame</li> <li>□ <b>TOWMBRL1</b> Towing member, low mounted under the frame (position 1)</li> <li>□ <b>TOWMBRM</b> Towing member, medium mounted in line with frame lower flange</li> <li>■ <b>RFEC-S</b> Rear frame end, straight cut (for regular platform applications)</li> <li>□ <b>RFEC-U</b> Rear frame end, upper cut (for e.g. tipper, refuse and hooklift applications)</li> <li>□ <b>C-RI4040</b> Towing coupling Ringfeder RF4040A G-150</li> <li>□ <b>C-RI4045</b> Towing coupling Ringfeder RF4045A G-150</li> <li>□ <b>C-RI5055</b> Towing coupling Ringfeder RF5055A G-150</li> <li>□ <b>C-RO400G</b> Towing coupling Rockinger 400 G-150</li> <li>□ <b>C-RO50</b> Towing coupling Rockinger 50 mm</li> <li>□ <b>C-VBG750</b> Towing coupling VBG 750V</li> <li>□ <b>C-VBG850</b> Towing coupling VBG 8500</li> <li>□ <b>TOWR-ONE</b> One rear towing device in frame end cross member</li> <li>■ <b>TREL-PK</b> Trailer electrical preparation kit (chassis/cab wiring)</li> <li>□ <b>TREL15</b> 15 pol electrical trailer connector (ADR certified)</li> <li>□ <b>TREL7-7</b> 2x7 pol (24N+24S) electrical trailer connectors (UADR)</li> <li>□ <b>TBC-DUO</b> Trailer brake connection, Duomatic</li> <li>□ <b>TBC-EC</b> Trailer brake connection, European Community</li> <li>□ <b>TRBR-STA</b> Stationary trailer brake control</li> <li>□ <b>TRB-STRE</b> Automatic low speed trailer brake activation (stretch brake) to avoid jack-knifing and to improve steerability</li> <li>□ <b>RUP-FOSL</b> Foldable and slidable aluminium rear underrun protection, EC</li> </ul>
<ul style="list-style-type: none"> <li>□ <b>EBS-STD</b> EBS (Electronic Brake System) standard package: <ul style="list-style-type: none"> <li>- ABS (Anti-lock Braking System)</li> <li>- Lining Wear Sensing (20 % left)</li> <li>- Lining Wear Control (incl. wear on the axle)</li> <li>- Brake Blending</li> <li>- Drag Torque Control</li> <li>- Diff Lock Synchronization</li> <li>- Diff lock Control</li> <li>- Brake Temperature Warning</li> <li>- External Brake Demand</li> <li>- Diagnosis Via Truck Electronic System</li> <li>- Traction Control System</li> <li>- Emergency Brake Assistance</li> <li>- Constant Wheel Brake Monitoring</li> <li>- Coupling Force Control</li> <li>- Automatic Parking Brake Activation</li> </ul> </li> <li>□ <b>AUXPARK</b> Two extra parking brake chambers</li> <li>□ <b>RST-MUL</b> Rear conventional multi-leaf suspension</li> <li>■ <b>RST-PAR1</b> Rear parabolic leaf suspension with normal stiffness</li> <li>□ <b>RST-PAR5</b> Rear progressive parabolic leaf suspension</li> <li>■ <b>FBREG-E</b> Front axle regulating brake valve for EBS</li> <li>■ <b>FRAME300</b> Frame rail section external height 300 mm</li> <li>■ <b>FST8080</b> Frame section thickness - web 8.0 mm / flange 8.0 mm</li> <li>□ <b>FIL-EEEB</b> Frame inner liner from end of engine end to end of bogie</li> <li>□ <b>FIL-EEEF</b> Frame inner liner from end of engine end to end of frame</li> <li>□ <b>FIL-FBEB</b> Frame inner liner from front of bogie to end of bogie</li> <li>□ <b>FIL-FBEF</b> Frame inner liner from front of bogie to end of frame</li> <li>■ <b>FIL-TXEB</b> Frame inner liner from transmission cross member to end of bogie</li> <li>□ <b>FIL-TXEF</b> Frame inner liner from transmission cross member to end of frame</li> <li>■ <b>BBOX-L</b> Battery box on left hand side</li> <li>□ <b>2BAT210B</b> Gel batteries 2x210 Ah</li> <li>■ <b>2BATT170</b> Batteries 2x170 Ah</li> <li>□ <b>2BATT225</b> Batteries 2x225 Ah</li> <li>■ <b>BATTAMP</b> Battery voltage and ampere gauge</li> <li>□ <b>BATTIND</b> Battery voltage, ampere and battery status gauge with visual alerts</li> <li>□ <b>ADR2</b> ADR adaptation - transportation of dangerous goods, 2 switches (1 inside cab in dashboard, 1 outside on cab back passenger side).</li> <li>□ <b>MSWI-A</b> ADR main switch - ADR switch circuit shut down</li> <li>■ <b>MSWI-C</b> Chassis main switch - battery box placed toggle switch circuit shut down</li> <li>□ <b>MSWI-R</b> Remote controlled main switch - key fob operated circuit shut down</li> <li>■ <b>UR-FUEL</b> Without right diesel tank Min volume 255l Max volume 810l</li> <li>■ <b>UL-FUEL</b> Without left diesel tank Min volume 160l Max volume 450l</li> <li>□ <b>ADTP-L</b> AdBlue tank on left hand side (for dual front axles between the axles)</li> <li>□ <b>ADTP-LF</b> AdBlue tank on left hand side at the front</li> </ul>	<ul style="list-style-type: none"> <li>■ <b>Standard Equipment</b></li> <li>□ <b>Optional Equipment</b></li> </ul>

For more detailed information about cab and powertrain equipment, please refer to separate specification sheets.

For all possible options and combinations of options please consult your Volvo sales contact who can create a specification to match your requirements using the Volvo Sales Support system (VSS).

The factory reserves the right to modify design and change equipment without previous notification. The specification can vary from country to country.

# MODEL RANGE

FMX D13 84 Rigid X-high T-ride FM 84F R3CTX

- approved
- FFEND-B** Standard mounted fenders on second front axle
- FFEND-T** Transport mounted fenders on second front axle
- RFEND-B** Rear 3 piece fenders with anti-spray function (all rear axles)
- RFEND-T** Transport mounted one-piece rear fenders
- RFH-BAS** Optimal fender installation (rear and 2nd front axle) with regard to legal demands, wheel/tyre sizes, chassis height and fifth wheel height.
- RFH-HIG** Highest fender installation (rear and 2nd front axle). Suitable for rough and very rough road conditions.
- RFH-LOW** Lower fender installation (rear and 2nd front axle). Suitable only for smooth road conditions. Increased risk of fender top wear.
- ATANK-AL** Aluminium air tanks
- ATANK-ST** Steel air tanks
- TL-LED** LED tail lamps (tail light, exterior marker light, brake light, hazard warning light, reverse light, rear fog light, licence plate light and reflector).
- BLIGHT-E** Emergency brake light
- FRACLOS** Frame end closing
- Rims and Tyres**
- RT-AL** Brushed aluminium rims with std holes (long stud fixing) on all axles
- RT-ALDP** Dura-Bright polished aluminium rims with std holes (long stud fixing) on all axles
- RT-ALDPD** Dura-Bright polished aluminium rims with countersunk holes (short stud fixing) on all axles
- RT-ALDU** Brushed aluminium rims with countersunk holes (short stud fixing) on all axles
- RT-STEEL** Steel rims on all axles
- WCAP** Wheel caps
- SPWT-D** Spare wheel with tyre equal to drive
- SPWT-F** Spare wheel with tyre equal to front wheel
- SWCP-LF** Spare wheel carrier on left side in front of rear axle
- SWCP-T** Temporary spare wheel carrier. Spare wheel is transport mounted (strapped on top of the frame rails) with plastic stripes.
- SWCP-TP** Spare wheel carrier transport mounted with the spare wheel on top of the frame rails
- JACK-12T** Jack 12 tonnes
- JACK-15T** Jack 15 tonnes
- JACK-20T** Jack 20 tonnes
- TOOL-BAS** Basic tools (combination screw driver, socket wrench)
- TOOLKIT** Extended tool kit
- INFLAHOS** Tyre inflation hose (18 metres) with nozzles in both ends
- GAUGE-TP** Tyre pressure gauge
- OBDEP-C** EU6 mandatory on board diagnostics, phase C regulations
- OBDEP-D** EU6 mandatory on board diagnostics, phase D regulations
- Powertrain equipment**
- ASO-C** One crawler gear
- ASO-ULC** Two crawler gears, one ultra low crawler and one crawler
- TRAP-HD** Reinforced gearbox application. For manual gearboxes a heavy-duty nodular iron range housing. For I-shift gearboxes (2412 excl.) a reinforced gear shifting system.
- TP-BAS** I-shift City gear changing software
- TP-CON** I-shift construction gear changing software
- TP-DIST** I-shift distribution gear changing software
- TP-HD** I-shift Heavy Duty gear changing software
- TP-LONG** I-shift long haul gear changing software
- AMSO-AUT** I-shift manual gear shift available in automatic mode incl kickdown function
- AVO-ENH** Enhanced I-shift software for construction and off road applications
- APF-ENH** Enhanced I-shift PTO functions (Auto Neutral / Reverse Inhibit / Split Box Connection)
- CD43-O** Dual plate clutch, plate diameter 430 mm
- RET-TH** Retarder (incl cooler) for manual and I-shift gearboxes with oil as brake fluid
- RET-TPT** Retarder for hydraulic gearbox
- TC-HWO** Cooler for hydraulic gearboxes - water/oil
- TC-MAOH2** Extra high performance cooler for manual/I-shift gearboxes - air/oil
- TC-MWO** Basic performance cooler for manual/I-Shift gearboxes - water/oil
- TC-MWOH2** High performance cooler for manual/I-Shift gearboxes - water/oil
- 2COM1100** Dual cylinder air compressor 760 cc / 1100 l/min
- 2COMP900** Dual cylinder air compressor 636 cc
- CLU-AIRC** Air compressor clutch automatically declutched when not needed in order to save fuel
- AIRIN-HI** High air intake
- AIRIN-LO** Low air intake
- ACL1ST-S** Air cleaner with additional filter element (primary + secondary)
- 24AL110B** Alternator 110 Ampere
- 24AL120B** Alternator 120 Ampere
- 24AL150B** Alternator 150 Ampere
- CCV-C** Closed crankcase ventilation
- PRIM-EL** Electrical priming pump for fast and easy bleeding of the fuel system
- PRIM-MAN** Manual priming pump for fast and easy bleeding of the fuel system
- AF-R** Hot fuel recirculation heated fuel filter
- EST-AID** Engine start pre-heating element
- 220EBH15** Engine block heater, 220 volt, 1.5 kW
- PTER-100** Rear engine mounted clutch independent power-take-off with flange connection (DIN 100 / ISO 7646)
- PTER-DIN** Rear engine mounted clutch independent PTO with splined shaft groove (female) for a close coupled pump (DIN 5462 / ISO 7653)
- PTER1400** Rear engine mounted clutch independent power-take-off with flange connection (SAE 1410 / ISO 7647)
- HPE-F101** Rear engine mounted hydraulic pump F1-101, fixed displacement, single flow
- HPE-F41** Rear engine mounted hydraulic pump F1-41, fixed displacement, single flow
- HPE-F51** Rear engine mounted hydraulic pump F1-51, fixed displacement, single flow
- HPE-F61** Rear engine mounted hydraulic pump F1-61, fixed displacement, single flow
- HPE-F81** Rear engine mounted hydraulic pump F1-81, fixed displacement, single flow
- HPE-T53** Rear engine mounted hydraulic pump F2-53/53, fixed displacement, twin flow
- HPE-T70** Rear engine mounted hydraulic pump F2-70/35, fixed displacement, twin flow
- HPE-V45** Rear engine mounted hydraulic pump VP1-45, variable displacement, single flow
- HPE-V75** Rear engine mounted hydraulic pump VP1-75, variable displacement, single flow
- PTPT-D** Automatic gearbox driven power take-off, 1 front/upper connection (DIN 5462 / ISO 7653) for plug-in pump (max. 850 Nm).
- PTPT-F** Automatic gearbox driven Power take-off, 1 front/upper rear facing flange connection (SAE 1410 / ISO 7647) for propeller shaft (max. 850 Nm).
- PTR-D** Mechanical gearbox driven low speed power take-off, 1 rear

■ Standard Equipment

□ Optional Equipment

For more detailed information about cab and powertrain equipment, please refer to separate specification sheets.

For all possible options and combinations of options please consult your Volvo sales contact who can create a specification to match your requirements using the Volvo Sales Support system (VSS).

The factory reserves the right to modify design and change equipment without previous notification. The specification can vary from country to country.

# MODEL RANGE

## FMX D13 84 Rigid X-high T-ride FM 84F R3CTX

- connection (DIN 5462 / ISO 7653) for plug-in pump (max. 1000 Nm).
- PTR-DH** Mechanical gearbox driven high speed power take-off, 1 rear connection (DIN 5462 / ISO 7653) for plug-in pump (max. 600 Nm).
- PTR-DM** Mechanical gearbox driven medium speed power take-off, 1 rear connection (DIN 5462 / ISO 7653) for plug-in pump (max. 600 Nm).
- PTR-F** Mechanical gearbox driven low speed power take-off, 1 rear flange connection (SAE 1410 / ISO 7647) for propeller shaft (max. 1000 Nm).
- PTRD-D** Mechanical gearbox driven high speed power take-off, 1 rear and 1 front connections (DIN 5462 / ISO 7653) for plug-in pumps (max. 870 Nm).
- PTRD-F** Mechanical gearbox driven high speed power take-off, 1 rear flange connection (SAE 1410 / ISO 7647) for propeller shaft (max. 870 Nm).
- HPG-F101** Gearbox mounted hydraulic pump F1-101, fixed displacement, single flow
- HPG-F41** Gearbox mounted hydraulic pump F1-41, fixed displacement, single flow
- HPG-F51** Gearbox mounted hydraulic pump F1-51, fixed displacement, single flow
- HPG-F61** Gearbox mounted hydraulic pump F1-61, fixed displacement, single flow
- HPG-F81** Gearbox mounted hydraulic pump F1-81, fixed displacement, single flow
- EIDLESD** Engine idle shut down
- Cab Interior, Driving**
  - STWPOS-L** Left hand drive
  - STWM-LE** Leather steering wheel
  - STGW-AD2** Mechanically adjustable steering wheel with neck tilt
  - STGW-ADJ** Mechanically adjustable steering wheel
  - AIRBAG** Airbag on driver side
  - INST-BAS** Basic level instrument cluster - 4 inch monochrome display 240x320 pix
  - DRC-AMII** Regeneration control of diesel filter particulates - auto initiation / manual on demand / manual inhibition
  - 1DAYDIG** One day digital tachograph, EC approved
  - 1DAYDIG2** Gen 2 one day digital tachograph, EC approved
  - 1DAYDIGP** One day digital tachograph, EC approved + Prep Kit for TAS-DIG2
  - ARSL** Additional road speed limiter (switch in dashboard)
  - CRUIS-E** Cruise control I-Cruise with controls in the steering wheel, I-Roll incl. Adding PVT-EXT/-MAP give I-See.
  - CRUISEC** Basic cruise control with controls in steering wheel
  - ESP-BAS1** Electronic Stability Program package intended for RIGID single vehicles or vehicle combinations with standard centre of gravity height when laden and for TRACTOR vehicle combinations with a single trailer or multiple trailers with ABS/EBS.
  - ESPC-RO** ESP (Electronic Stability Program) functionality control - Reduced / Off
  - HWSS-AC** Adaptive cruise control with forward collision warning
  - HWSS-ACB** Adaptive cruise control with forward collision warning (stationary and moving objects) and emergency braking. Using both radar and camera to collect info.
  - HWSS-FCB** Forward collision warning (stationary and moving objects) with emergency braking
  - LSS-DW** Lane keeping support - lane departure warning system
  - LCS** Lane Change Support
  - DAS-W** Driver Alert Support (drowsy driver warning)
  - RSENS-W** Wiper rain sensor
  - CU-ECC** Fully electrically controlled air conditioning with sun sensor
- CU-ECC2** Fully electrically controlled air conditioning with sun sensor, mist sensor, air quality sensor and carbon filter
- CU-MCC** Electrical manually controlled air conditioning
- IMMOBIL** Immobiliser
- ALARM-B** Burglar alarm - cab
- ALARM-E** Burglar alarm - cab/body/trailer
- ALCOLOCK** Alcolock
- BUPMON** Back-up monitor including a 7 inch colour display integrated in dashboard, Waeco CCD-camera (delivered loose in cab) with a heated lens, motorised lens protection, 1 m pigtail cable (front) and 10 metres chassis cable for tractor /20 metres for rigid. Camera wirings not installed. Use PCA30081 for installation.
- PHONE-PK** Telephone preparation kit (antenna, antenna attachment, cable from antenna to radio shelf).
- WLIFT-AD** Electrical window lift, auto up/down driver side; el operated on passenger side
- WLIFT-EB** Electrical window lift. From the driver side both windows can be operated and from the passenger side the passenger side window can be operated.
- ISUNS-BS** Manually manoeuvred side interior sun visor (roller blind type) on both sides
- ISUNS-DS** Manually manoeuvred side interior sun visor (roller blind type) on driver side
- ISUNF-B** Interior front plastic sun visors (driver and passenger side) without mirror on driver side
- ISUNF-MD** Interior front plastic sun visors (driver and passenger side) with mirror on driver side
- ISUNF-RE** Electrical textile interior sun visor (roller blind) integrated in front shelf
- ISUNF-RM** Manual interior textile sun visor (roller-blind) integrated in front shelf
- CSPU-S** One open storage (behind push open lid) in upper part of dash panel center section
- ADFS** Two extra DIN slots in front shelf (push/pull storage), 165x40x180 mm (WxHxD)
- BUPALARM** Back-up alarm
- RTOLL-PK** Preparation kit for road toll collect (GPS/GSM antenna and cables)
- LOADIND** Load indicator with dashboard display. Measures axle pressures, load weight and total weight of truck and one trailer.
- REMC-MF** Wireless remote control - multi functional
- FIREXT2G** Fire extinguisher 2 kg, German decal
- FIREXT3S** Fire extinguisher 3 kg, Swedish/English decal
- WARNVEST** Warning vest. Fulfils European standard according to EN 471 class 2.
- WARNTRI2** Two warning triangles
- AIDKIT** First aid kit containing sticking plaster, washing and drying pads, compresses, elastic bandages, respiratory mask, gloves and scissors
- AIDKIT1B** First aid kit containing sticking plaster, compresses, elastic bandages, gloves, scissors, triangular bandage, bandaging cloths, adhesive tape and rescue sheet (German requirements)
- WARNLAMP** Portable warning lamp with batteries
- LAMP-IN** Inspection lamp with 10 m cable
- BULBKIT** Bulb and fuse kit
- WRITEPAD** Writing pad with spring-loaded paper clip

### Cab Interior, Living

- Standard Equipment
- Optional Equipment

For more detailed information about cab and powertrain equipment, please refer to separate specification sheets.

For all possible options and combinations of options please consult your Volvo sales contact who can create a specification to match your requirements using the Volvo Sales Support system (VSS).

The factory reserves the right to modify design and change equipment without previous notification. The specification can vary from country to country.

# MODEL RANGE

## FMX D13 84 Rigid X-high T-ride FM 84F R3CTX

- UPHTRI10** Seat upholstery with black embossed textile insert, black vinyl bolster and blue vinyl side insert & textile interior trim in matching grey/blue nuances
- UPHTRI11** Seat upholstery with light grey embossed textile insert, raven metallic vinyl bolster and red vinyl side insert & vinyl/textile interior trim in matching skylark/grey/black nuances
- UPHTRI12** Seat upholstery with blue soft textile insert, black vinyl bolster & textile interior trim in matching grey/black/blue colours
- UPHTRI13** Seat upholstery with dark grey leather insert and black leather bolster & vinyl/textile interior trim in matching grey/black nuances
- UPHTRI14** Seat with dark grey leather insert and black leather bolster & textile interior trim in matching grey and black colours
- DST-CF1** Driver seat, comfort, suspended
- DST-CF4** Driver seat, comfort, suspended, belt in seat
- DST-CF5** Driver seat, comfort, suspended, belt in seat, electrically heated
- DST-CF6** Driver seat, comfort, suspended, belt in seat, electrically heated, ventilated
- SBD-RED** Red safety belts, passenger and driver seats
- SBPRE-DS** Driver seat belt pretensioner
- PST-BAS1** Passenger seat, basic, non suspended
- PST-BENC** Bench passenger seat
- PST-CF4** Passenger seat, comfort, suspended, belt in seat
- PST-CF5** Passenger seat, comfort, suspended, belt in seat, electrically heated
- PST-STD2** Passenger seat, regular, non suspended
- PST-STD4** Passenger seat, regular, suspended
- SBPRE-PS** Passenger seat belt pretensioner
- ARM-DBPS** Two armrests on driver seat and one (outer) on passenger seat
- ARMRE-BB** Two armrests on both driver and passenger seats
- ARMRE-DB** Two armrests on driver seat
- ARMRE-PB** Two armrests on passenger seat
- ARMRE-PS** Single armrest (next to driver) on passenger seat
- ARU-BAS** Vinyl armrest upholstery
- ARU-LEA** Leather armrest upholstery
- FMAT-RU2** Two black rubber floor mats with raised edges and an extended side (FMX)
- FMAT-RUB** Two black rubber floor mats
- FMAT-T2E** Two dark grey textile floor mats and two black rubber floor mats with an extended side (FMX)
- FMAT-TX2** Two textile (dark grey on FH/FM, black on FH16) and two black rubber floor mats
- LBK-RES** Lower fixed rest kit, foldable to rear wall
- LBK70** Lower fixed bunk, not foldable - 2000x700 mm. Safety net included.
- ULBK** Without lower bunk
- MATL-FI** Mattress lower bunk - firm for over approx. 100 kg, pocket springs.
- MATL-SF** Mattress lower bunk - semi-firm up to approx 100 kg, pocket springs.
- OLMAT-BA** Overlay mattress protector, 28 mm thick black textile
- OLMAT-PR** Overlay mattress protector, 35 mm thick black textile
- TBK60F** Fixed top bunk 600x1900 mm, foldable up to 52 degrees to rear wall (depending on cab version and upper storage). Safety net included.
- TBK70F** Fixed top bunk 700x1900 mm, foldable up to 52 degrees to rear wall (depending on cab version and upper storage). Safety net included.
- PH-CAB2** Cab parking heater, 2 kW
- PH-ENGCA** Engine and cab parking heater
- PH-SS** Short stop heater
- SLCP-BAS** Basic sleeper control panel (controlling interior light, parking heater, roof hatch and door lock)
- SAFE** Key operated safe box under bed (FH) or at bed end (FM)
- ETSB-F** Storage on engine tunnel - on front top
- ETSB-FR** Storage on engine tunnel - on front top and at rear cab wall
- ETSB-FRS** Storage on engine tunnel - on front top & at rear cab wall & storage immersed into tunnel on RH side
- ETSB-FS** Storage on engine tunnel - on front top and storage immersed into tunnel on right hand side
- ETSB-R** Fixed engine tunnel storage box at rear cab wall
- ETSB-RS** Storage on engine tunnel - at rear cab wall and storage immersed into tunnel on right hand side
- ETSB-S** Storage on engine tunnel - immersed into tunnel on right hand side
- RUS-BAS** Rear cab upper storage 154 litres (300 mm high)
- RUS-HIG** Rear cab upper storage 245 litres (440 mm high)
- TABLE** Foldable and height adjustable table to be mounted to the lower bunk
- REF-ICPK** Refrigerator preparation kit, engine tunnel mounted
- REFR-RUS** 28 litre rear upper wall mounted refrigerator with dividers
- MICRO-PK** Preparation kit for microwave oven (el. cables to front shelf)
- BOTH-D** One 1.5 litre plastic soft-drink bottle holder under dashboard centre section
- COFMA-PK** Preparation kit (24V) for coffee maker
- INLI-BAS** Interior white light with smooth light transition at on/off, no dimming
- INLI-NL** Interior white and red (night) light with smooth light transition at on/off
- INLI-NLD** Interior white and red (night) light with smooth light transition at on/off and dimmer
- ARL-FLEX** Two (driver and passenger side) reading lamps with flexible arms (snake lamps) and led lamps fitted on side walls
- RH-EE** Without roof hatch, sky window / emergency exit (tinted glass)
- RH-ETR** Roof hatch - Electrically operated / Tinted glass / Rear opening
- RH-MSR** Roof hatch - Manually operated / Steel / Rear opening
- RH-MTR** Roof hatch - Manually operated / Tinted glass / Rear opening
- URH** Without roof hatch
- SWIND-BS** Extra side window on both sides
- SWIND-PS** Rear side window on passenger side
- VANMIR** Vanity mirror in front shelf lid.  
In sleeper cab on passenger side and in high/extra high cabs in middle section of the front shelf.
- AS-FUS** One extra shelf in each of the two front upper storage compartments.  
Only 1 shelf if microwave oven mounted in one of the two compartments.
- INFOT-PK** Preparation kit (bracket, security straps, power cable, antenna cable and aux cable) for mounting of a television above driver door.

### Cab Exterior

- PAICS-B** Basic painting in a lightning grey colour of cab surrounding parts (mirror housings, insteps, bumper and if fitted bumper spoiler and sun visor).  
If fitted roof air deflector, side air deflector and chassis fairings are always painted in cab colour.
- GLAS-TIN** Tinted windows (front/side/rear)
- AWIND-RF** Rear fixed window (without curtains)
- DGLAS-L** Laminated door glass
- LOCK-MAN** Manual door locking
- LOCK-MRP** Manual door locking with internal remote control (from driver side) of passenger door
- LOCK-REM** Central door locking with remote control
- BUMP-HD** Heavy duty front bumper
- AUXFS** Extra cab side foot-step
- GUARD-EH** Guard plate for cooling pipes and oil sump

Standard Equipment

Optional Equipment

For more detailed information about cab and powertrain equipment, please refer to separate specification sheets.

For all possible options and combinations of options please consult your Volvo sales contact who can create a specification to match your requirements using the Volvo Sales Support system (VSS).

The factory reserves the right to modify design and change equipment without previous notification. The specification can vary from country to country.

# MODEL RANGE

## FMX D13 84 Rigid X-high T-ride FM 84F R3CTX

<input type="checkbox"/> <b>SIDEH-B</b>	Guide rail on day cab driver side	<input type="checkbox"/> <b>ROS-ILP</b>	the cab sign variants Wiring preparation kit (wires and switch) for cab sign or roof air deflector illumination
<input type="checkbox"/> <b>SIDSTP-R</b>	Side ladder and guide rail on on day cab driver side	<input type="checkbox"/> <b>CSGN-FMX</b>	FMX decal in the cab roof sign area
<input checked="" type="checkbox"/> <b>BUGNET</b>	Radiator screen / Mosquito net (PVC coated fibreglass) in front of radiator	<input checked="" type="checkbox"/> <b>HORN-F1S</b>	One front mounted (behind grille) single tone air horn, Jericho. Operated by steering wheel buttons.
<input type="checkbox"/> <b>CTILT-P-E</b>	Electrical cab tilt pump	<input type="checkbox"/> <b>HORN-R2S</b>	Two roof mounted single tone chromed air horns. Operated by steering wheel buttons.
<input checked="" type="checkbox"/> <b>CTILT-P-M</b>	Manual cab tilt pump	<input type="checkbox"/> <b>ANT-CBR</b>	Right hand side roof mounted foldable antenna and cables for CB radio, single aerial.
<input type="checkbox"/> <b>FCABS-A</b>	Air front cab suspension	<input type="checkbox"/> <b>ACCBR-AP</b>	Front, middle & rear roof mounted accessory brackets
<input checked="" type="checkbox"/> <b>FCABS-M</b>	Mechanical cab suspension	<input type="checkbox"/> <b>ACCBR-F</b>	Front roof mounted accessory bracket
<input type="checkbox"/> <b>RCABS-A</b>	Air rear cab suspension	<input type="checkbox"/> <b>ACCBR-FM</b>	Front & middle roof mounted accessory brackets
<input checked="" type="checkbox"/> <b>RCABS-M</b>	Mechanical rear cab suspension	<input type="checkbox"/> <b>ACCBR-FR</b>	Front & rear roof mounted accessory brackets
<input type="checkbox"/> <b>MIRCOMFX</b>	El heated & operated robust main rear view mirrors, electrically heated wide angle mirrors (both sides). Close view mirror on passenger side.	<input type="checkbox"/> <b>ACCBR-M</b>	Middle roof mounted accessory bracket
<input checked="" type="checkbox"/> <b>MIRSTDX</b>	Electrically heated robust main rear view mirrors and wide angle mirrors (both sides). Close view mirror on passenger side.	<input type="checkbox"/> <b>ACCBR-R</b>	Rear roof mounted accessory bracket
<input checked="" type="checkbox"/> <b>AMIR-F20</b>	Front close view mirror above windscreen, passenger side (radius 200 mm)	<input type="checkbox"/> <b>ACCBR-RM</b>	Rear & middle roof mounted accessory brackets
<input type="checkbox"/> <b>SUNV-H</b>	Exterior transparent dark grey front sun visor	<input type="checkbox"/> <b>REFS-TW</b>	Reflecting white cab side stripes by-packed in cab
<input type="checkbox"/> <b>AD-ROOF</b>	Roof air deflector. Design (length, height etc.) automatically calculated and varies depending on vehicle total height (chassis height, cab type, tyres etc).	<input type="checkbox"/> <b>REFS-TY</b>	Reflecting yellow cab side stripes by-packed in cab
<input type="checkbox"/> <b>AD-SIDEL</b>	Long cab side air deflector	<b>Superstructure preparations</b>	
<input type="checkbox"/> <b>AD-SIDES</b>	Short cab side air deflectors	<input type="checkbox"/> <b>BP-MI02</b>	Body Builder preparation package Mixer (02)
<input checked="" type="checkbox"/> <b>HL-BAS2</b>	Halogen H1 head lamps (heavy duty)	<input type="checkbox"/> <b>BP-TI03</b>	Body Builder preparation package Tipper (03)
<input type="checkbox"/> <b>HL-BASIC</b>	Halogen H7 head lamps	<input type="checkbox"/> <b>SRWL-PK</b>	Wiring preparation for chassis mounted working lamps and a 3-position switch (On/Off/Reverse auto on). Max load 280W.
<input type="checkbox"/> <b>HL-CLEAN</b>	High pressure headlamp cleaner	<input type="checkbox"/> <b>SWL-2FW</b>	Two H3 70W white front chassis mounted (LH/RH side) working lamps and a 2-position switch (On/Off)
<input type="checkbox"/> <b>HLP-ST</b>	Steel headlamp protection	<input type="checkbox"/> <b>SWL-2RW</b>	Two H3 70W white rear chassis mounted (LH/RH side) working lamps and a 2-position switch (On/Off)
<input checked="" type="checkbox"/> <b>HL-ADJ</b>	Adjustable headlamps to adjust the height of the light beam	<input type="checkbox"/> <b>SWL-4W</b>	Four H3 70W white front (2) and rear (2) chassis mounted (LH/RH side) working lamps and a 2-position switch (On/Off)
<input checked="" type="checkbox"/> <b>DRL-LED</b>	V-shaped ("V-light") day running light (LED). Turned on low beam gives a dimmed "V-light".	<input type="checkbox"/> <b>SWL-PK</b>	Wiring preparation for chassis mounted working lamps and a 2-position switch (On/Off). Max load 280W.
<input type="checkbox"/> <b>ASL-RF2</b>	Two Hella H11 70W spot lamps in sign box (one on each side of the Globetrotter sign)	<input type="checkbox"/> <b>WL-CHPK</b>	Preparation kit (switch and cable) for working lamp, max 2x70 W. Connector on chassis at gearbox.
<input type="checkbox"/> <b>ASL-RFPK</b>	Preparation kit for two spot lamps in sign box	<input type="checkbox"/> <b>WLC-H2A</b>	Two H3/70W working lamps with amber coloured lens high mounted back of cab (switch incl).
<input type="checkbox"/> <b>BEACOA2F</b>	Two front roof mounted amber rotating beacon warning lamps. Mounted on accessory bracket if ordered, otherwise on cab roof on both sides of the hatch.	<input type="checkbox"/> <b>WLC-H2W</b>	Two H3/70W working lamps, white lens high mounted back of cab (switch incl).
<input type="checkbox"/> <b>BEACOA2R</b>	Two rear roof mounted (on accessory bracket) amber warning lamps. Rotating beacon lamps mounted on sleeper cab. Flashing LED lamps mounted on high/extra high sleeper cabs.	<input type="checkbox"/> <b>WLC-PKCH</b>	Preparation kit (cables and switch) for cab mounted chassis working lamp. Max load 280W.
<input type="checkbox"/> <b>BEACON-P</b>	Prepared wiring (switch and connected relay included) for warning lamps on cab roof. Max load 300 W.	<input type="checkbox"/> <b>WLC-PKH</b>	Preparation kit (cables and switch) for high mounted working lamps back of cab (pass through in cab rear roof included). Max load 280W.
<input type="checkbox"/> <b>BEACONA4</b>	Four roof mounted amber warning lamps. 2 front mounted (on accessory bracket if ordered) rotating beacon lamps. 2 rear mounted (on mandatory accessory bracket) rotating beacon lamps on sleeper cab. 2 rear mounted (on mandatory accessory bracket) flashing LED lamps on high/xhigh sleeper cabs.	<input type="checkbox"/> <b>WLC-PKL</b>	Preparation kit (cables and switch) for low mounted working lamps back of cab (pass through in cab rear wall included). Max load 280W.
<input type="checkbox"/> <b>CABPT-R1</b>	One front cab roof pass through on passenger side	<input type="checkbox"/> <b>WLC-PKLH</b>	Preparation kit (cables and switch) for low and high mounted working lamps back of cab (pass throughs in rear wall and rear roof included). Max load 280W.
<input checked="" type="checkbox"/> <b>CABPT-R2</b>	Two front cab roof pass throughs, one on each side	<input type="checkbox"/> <b>ECBB-BAS</b>	Body builder electrical centre without any body builder module
<input type="checkbox"/> <b>SPOTP-F</b>	Spotlamp preparation in cab front, max 280W	<input checked="" type="checkbox"/> <b>ECBB-HIG</b>	Body builder electrical centre with cab body builder module
<input type="checkbox"/> <b>SPOTP-R</b>	Spotlamp preparation on cab roof, max 280W	<input type="checkbox"/> <b>BBCHAS1</b>	One 7-pole connector for Body builder interface. Wiring harness routed from the bodybuilder electrical distribution box inside the cab to a connection point inside the right frame rail beside the gearbox.
<input type="checkbox"/> <b>SPOTP-RF</b>	Spotlamp preparation on cab roof and in cab front, max 2x280W	<input type="checkbox"/> <b>BBCHAS3</b>	Three 7-pole connectors for Body builder interface. Wiring harness routed from the bodybuilder electrical distribution box inside the cab to a connection point inside the right frame rail beside the gearbox.
<input type="checkbox"/> <b>ROS-IL</b>	Illuminated roof sign with switch in radio shelf. Switch for turning on/off.	<input type="checkbox"/> <b>BEPR-T2</b>	Body builder electrical software preparation for tipper with remote control
<input type="checkbox"/> <b>ROS-IL2</b>	Preparation kit for installing an illuminated roof sign*. It includes a prerouted cable harness, a switch and LED-lamps. The switch is connected in the radio shelf middle section. Switch cap with icon, are enclosed in cab. Lamps in sign are mounted. The stripe in the Globetrotter window is selected via	<input type="checkbox"/> <b>EXSTER</b>	Support for external steering control via body builder module
<input checked="" type="checkbox"/> <b>Standard Equipment</b>		<input type="checkbox"/> <b>TD-BAS</b>	Trailer detection without LED sensor
<input type="checkbox"/> <b>Optional Equipment</b>		<input checked="" type="checkbox"/> <b>TD-LED</b>	Trailer detection with LED sensor
		<input type="checkbox"/> <b>FRFS-B5</b>	Frame rail free space on both sides to give space for crane

For more detailed information about cab and powertrain equipment, please refer to separate specification sheets.

For all possible options and combinations of options please consult your Volvo sales contact who can create a specification to match your requirements using the Volvo Sales Support system (VSS).

The factory reserves the right to modify design and change equipment without previous notification. The specification can vary from country to country.

# MODEL RANGE

FMX D13 84 Rigid X-high T-ride FM 84F R3CTX

---

legs or other equipment.  
One front axle with day cab: 515/507 mm (L/R side).  
One front axle with long cab: 288/360 mm (L/R side).  
Two front axles with short cab: 632/572 mm (L/R side).  
Two front axles with long cab: 405/485 mm (L/R side).

- **FBA-BTF** Lower front body attachments for torsionally flexible platform body
- **FBA-BTSF** Lower front body attachments for torsionally semi-flexible body (van or curtainsider)
- **HBA-FSFB** Holes for body attachments, flexible/semi-flexible body
- **HBA-SB** Holes for body attachments, stiff body
- **RBA-T2** Lower rear body attachments for helper frame
- **CRANEPK1** Crane plates mounted to frame, interface for crane capacity up to 10 ton meter
- **CRANEPK2** Crane plates mounted to frame, interface for crane capacity up to 20 ton meter
- **CRANEPK4** Crane plates mounted to frame, interface for crane capacity up to 40 ton meter
- **AUXL-SPK** Electrical preparation kit (wiring and a switch in dashboard) for snow plough lights.  
Preparation for installation of additional headlights and additional turning indicators.
- **TAILPRE2** Tail lift preparation kit, wireless remote operation
- **TAILPREP** Tail lift preparation kit, wire remote operation
- **AESW2** Two Body builder bistable electrical switches (marked AUX1 / AUX2)
- **AESW2PK** Two Body builder bistable electrical switches (marked AUX1/AUX2) and in an empty 4-group preparation another four bistable switches with dummy switch caps
- **AUXSW-4** Wiring for 4 extra hardwired switches (from Body builder electrical centre to switch positions)

## Services

- **TGW-4GWL** Telematics gateway with 4G modem
- **FMS-PK** Fleet Management System gateway, preparation kit
- **DRUT** My truck app gives the driver instant status information and control of the vehicle remotely from a smartphone or tablet. The variant enables the My truck app to connect to the vehicle.

**VOLVO**

Volvo Truck Corporation

volvotrucks.com