

MODEL RANGE

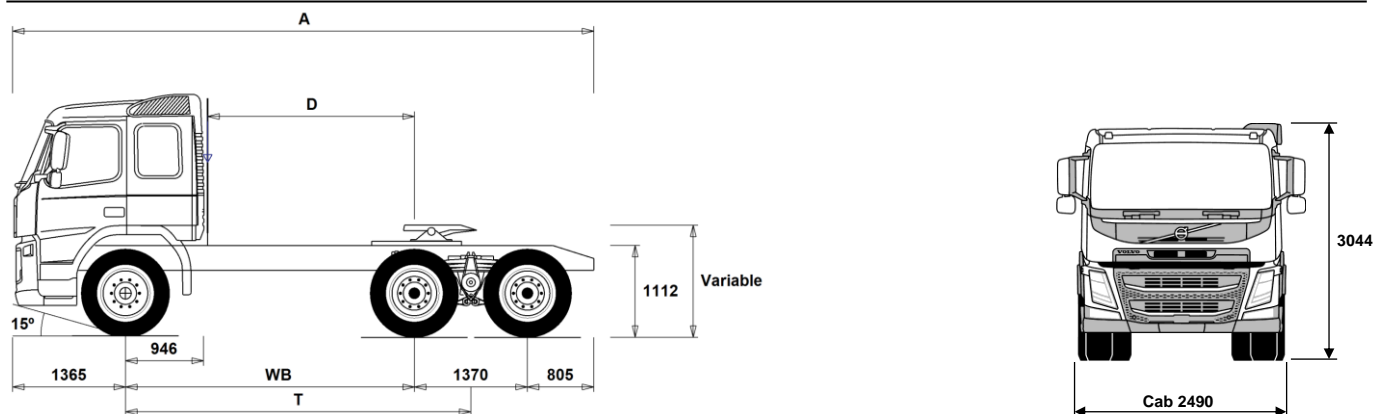

Volvo Trucks. Driving Progress

FM 13 6x4 Tractor - High B Ride - N3 Cranked front axles for on road work FM 64 T3HB



Chassis Dimensions [mm]

WB Wheelbase	3000	3200	3600	3900
A Overall Chassis Length	6540	6740	7140	7440
D Center of rear axle to back of cab	2004	2204	2604	2904
T Theoretical Wheelbase	3685	3885	4285	4585

Chassis Weights [kg]

Front Axle	4560	4580	4620	4650
Rear Bogie	3510	3505	3505	3500
Kerb Weight	8070	8085	8125	8150

Turning Diameter [mm]

Turning Circle Diameter Kerb to Kerb	13300	13900	15100	16100
Turning Circle Diameter Wall to Wall	14800	15400	16600	17500

Plated Weights [kg]

	Plated	Design
Gross Vehicle Weight	26000	29000
Gross Combination Weight	44000	44000
Front Axle	8000	8000
Rear Bogie	19000	21000

Important Notes

Chassis Dimensions

Cab Height: +416 mm for CAB-HSLP, -169 mm for CAB-LSLP.
 Front Axle to Back of Cab: -424 mm for CAB-DAY, -6 mm for CAB-LSLP.
 D-measure includes a front clearance of 50 mm and for rigid trucks also a subframe of 100 mm.
 Height can vary ± 20 mm for leaf and ± 10 mm for air suspension.
 All dimensions are for unladen chassis and any tag axles down.

Weight and dimensions are based upon the following tyres:

Front Axle Tyres: 315/80R22.5
 Drive Axle Tyres: 315/80R22.5

Chassis weight includes oil, water, AdBlue, 0 litres fuel and without driver. Kerb weight can vary $\pm 3\%$.

Turning diameters are theoretically calculated.

Legal weights can differ from country to country.

For more detailed weight information, including optional equipment weights, ask your Volvo sales contact to enter your specification into the Volvo Weight Information system (WIS).

Do NOT use this drawing for bodybuilding. Refer to Volvo Bodybuilder Instructions and chassis assembly drawing FM64T3HB.

MODEL RANGE

FM 13 6x4 Tractor - High B Ride - N3 Cranked front axles for on road work FM 64 T3HB

TRUCK USE

- **RC-ROUGH** Operating class on/off road

CORE COMPONENTS

- **CHH-HIGH** Chassis height high - N3 "On Road" chassis - For a specific loading height always check the unique BEP chassis drawing
- **RADD-BR** B-ride rear three spring bogie suspension
- **FM-DAY** Day cab - with steel safety cage design
Designed and built to Swedish impact and ECE R29 regulations
- **FM-HSLP** Globetrotter cab - with steel safety cage design
Designed and built to Swedish impact and ECE R29 regulations
- **FM-LSLP** Low sleeper cab - with steel safety cage design
Designed and built to Swedish impact and ECE R29 regulations
- **FM-SLP** Sleeper cab - with steel safety cage design
Designed and built to Swedish impact and ECE R29 regulations
- **EU6SCR** Emission level - Euro 6
- **D13 420S** D13K420 12.8 litre engine developing 420hp at 14-1800rpm.
Peak torque 2100Nm at 860 -1400rpm.
- **D13 460S** D13K460 12.8 litre engine developing 460hp at 14-1800rpm.
Peak torque 2300Nm at 900-1400rpm.
- **D13 500S** D13K500 12.8l engine developing 500hp at 14-1800rpm.
Peak torque 2500Nm at 1000-1400rpm.
- **D13K420** D13K420 - 420hp engine
- **D13K460** D13K460 - 460hp engine
- **D13K500** D13K500 - 500hp engine
- **EBR-EPG** Exhaust brake controlled by steering column switch
- **EBR-EPGC** Exhaust pressure governor for I shift gearbox
- **EBR-VEB+** Volvo engine brake + and exhaust pressure governor, enhanced performance from additional exhaust rocker control. Retardation 375kW
- **AT2612F** AT2612F 12-speed "I-shift" automated mechanical gearbox suitable for gross train weights up to 60tonne only refer to sales engineering when used in conjunction with a PTO
- **ATO2612F** ATO2612F 12-speed "I-shift" overdrive automated mechanical gearbox suitable for gross train weights up to 60tonne refer to sales engineering when used in conjunction with a PTO
- **PT2606** Powertronic automatic 6-speed gearbox, max. engine torque 2600 Nm, max. permitted GCW 130000 kg
- **SPO2812** SPO2812 - 12 speed I-shift Dual Clutch automated mechanical gearbox GCW 60tonne
- **RTH2610F** RTH2610F hub reduction tandem 26tonne drive axles, GCW 100 tonnes with differential and cross locks*
* Cross locks replaced by a dog clutch if tandem axle lift is specified
- **RTS2310A** RTS2310A single reduction tandem 23tonne drive axles with differential and cross locks* - design GCW 100tonnes.
* Cross locks replaced by a dog clutch if tandem axle lift is specified.
- **RTS2370A** RTS2370A single reduction tandem 23tonne drive axles with differential and cross locks* - design GCW 70tonnes.
* Cross locks replaced by a dog clutch if tandem axle lift is specified.

PACKAGES

- **DRIVEFM** Cab Package: Drive
- **DRIVEFM+** Cab Package: Drive +
- **BEDFM** One bed resting package
- **AUDHIG** High Power Audio system: RDS radio with CD player - also playing MP3/WMA files from CD -, with integrated bluetooth phone and USB/Line inputs. FM/AM antenna, speakers in dashboard, doors, and sleeping compartment.
- **MEDIA** AM/FM Bluetooth radio without CD player.

- Standard Equipment
- Optional Equipment

For more detailed information about cab and powertrain equipment, please refer to separate specification sheets.

For all possible options and combinations of options please consult your Volvo sales contact who can create a specification to match your requirements using the Volvo Sales Support system (VSS).

The factory reserves the right to modify design and change equipment without previous notification. The specification can vary from country to country.

□ MEDIADF

- USB and Aux line inputs.
 - Speakers in dashboard, doors, and sleeping compartment.
 - 7" touch screen with personal apps.
 - AM/FM Bluetooth radio without CD player.
 - USB and Aux line inputs.
 - Speakers in dashboard, doors, and sleeping compartment.
 - 7" touch screen with personal and professional apps.
 - Dynafleet vehicle on-board data display with office internet support.
- **MEDIANAV** AM/FM Bluetooth radio without CD player.
USB and Aux line inputs.
Speakers in dashboard, doors, and sleeping compartment.
7" touch screen with personal and professional apps.
Truck based satellite navigation (live updates not included)
 - **MEDIANDF** AM/FM Bluetooth radio without CD player.
USB and Aux line inputs.
Speakers in dashboard, doors, and sleeping compartment.
7" touch screen with personal and professional apps.
Truck based satellite navigation (live updates not included)
Dynafleet vehicle on-board data display with office internet support.
 - **VISI15** Visibility Package

CCHASSIS

- **FST-PAR** Front suspension type - 2 leaf parabolic springs
- **FST-PAR3** Front suspension type - 3 leaf parabolic springs
- **FAL10.0** Front axle design capacity 10 tonnes - Ensure that you have checked the tyre load index
Front axle design capacity 7.1 tonnes
- **FAL7.1** Front axle design capacity 7.1 tonnes
- **FAL7.5** Front axle design capacity 7.5 tonnes
- **FAL8.0** Front axle design capacity 8.0 tonnes - Ensure that you have checked the tyre load index
- **FAL8.5** Front axle design capacity 8.5 tonnes
- **FAL9.0** Front axle design capacity 9.0 tonnes - Ensure that you have checked the tyre load index
- **FSM-LUB** Lubricated rear shackles on front suspension pins and bushings
- **FSTAB** Front anti-roll bar
- **FSTAB2** Front anti-roll bar medium stiffness
- **FSTAB3** Front stiff anti-roll bar
- **RAL21** Rear bogie design capacity 21 tonnes
- **ACTST-TO** Volvo Dynamic Steering (VDS) with with extra electronic pump and torque overlay
- **ASFE-BAS** Active steering feature - Basic - Volvo Dynamic Steering only
- **ASFE-OG** Active steering feature - Volvo Dynamic Steering with stability assist - oversteer
- **ASFE-PO** Active steering feature - Volvo Dynamic Steering with personal settings and stability assist
- **ASFE-PS** Active steering feature - Volvo Dynamic Steering with personal settings
- **PSS-SING** Single power steering system
- **PSP-FIX** Power steering pump with fixed displacement
- **PSP-VAR** Power steering pump with variable displacement
- **EBS-MED** EBS medium package including "hill" hold function
- **RST-PAR1** Rear Suspension, Parabolic springs
- **FBREG-E** Front regulating brake valve, EBS
- **FBREG-RP** Front regulating brake valve, reduced pressure/low pressure range
- **FRAME300** Frame rail section external height 300 mm
- **FST7070** Frame thickness - web and flange 7.0mm
- **FST8080** Frame thickness - web and flange 8.0mm
- **FIL-EEEB** Inner liner from end of engine to end of bogie
- **FIL-TXEB** Inner liner from gearbox member to end of bogie
- **BBOX-L** Battery box located on left hand side
- **BATS-D** Dual energy battery system - 2 living batteries and 2 starter batteries.

MODEL RANGE

FM 13 6x4 Tractor - High B Ride - N3 Cranked front axles for on road work FM 64 T3HB

- 2BAT210B** 2 x 210 Ah capacity Gel batteries
 - 2BATT170** 2 x 170 Ah capacity batteries
 - 2BATT225** 2 x 225 Ah capacity batteries
 - BATTAMP** Battery voltage and ampere gauge
 - BATTIND** Battery charge indication
 - ADR2** ADR package for transportation of dangerous goods on road (Note does NOT include safe loading pass package if required this is quoted separately)
 - MSWI-A** Main switch - ADR switch circuit shut down
 - MSWI-C** Main switch - Chassis mounted toggle switch by battery box
 - MSWI-R** Main switch - Key fob operated remote controlled
 - R330A71** Right aluminium 710 mm D-shaped fuel tank, 330 litres volume
Min volume 150l
Max volume 810l
 - UL-FUEL** Without left fuel tank
Min volume 160l
Max volume 550l
 - ADTP-BC** AdBlue tank behind/under cab on right hand side
 - ADTP-L** AdBlue tank on left hand side
 - ADTP-R** AdBlue tank on right hand side
 - ADB048** AdBlue tank usable volume 48 litres
 - ADB050** AdBlue tank usable volume 50 litres - under cab
 - ADB064** AdBlue tank usable volume 64 litres
 - ADB068** AdBlue tank usable volume 68 litres
 - ADB090** AdBlue tank usable volume 90 litres
 - FCAP-L** Locking fuel filler cap
 - FUFF-AS** Fuel filling anti-spillage device
 - FUFF-ATS** Fuel filling anti-theft and anti-spillage devices
 - ESH-LEFT** Horizontal silencer, left exhaust outlet
 - ESH-REAR** Horizontal silencer, rear exhaust outlet
 - ESH-RIGH** Horizontal silencer, right exhaust outlet
 - ESH-VERT** Horizontal silencer, vertical exhaust outlet
 - EXST-SSP** Stainless steel exhaust stack - NOT polished
 - EXST-ST** Steel exhaust stack
 - WHC-FIX2** Two fixed wheel chocks
 - WHC-FOL2** Two foldable wheel chocks
 - WHCP-F** Wheel chock(s) stored in the front part of the vehicle
 - WHCP-M** Wheel chock(s) stored in the middle part of the vehicle
 - WHCP-T** Transport mounted wheel chock(s) stored in cab outer luggage locker
 - TB-L80** Toolbox 800 mm, left side
 - TB-R80** Toolbox 800 mm, right side
 - SUP-BAS** EC approved chassis side guards
 - SUP-LOW** EC approved low chassis side guards
 - CHAIN-S** Snow chains
 - HOOK-SC** Snow chain hooks
 - TOWF-NO1** One front towing device
 - TOWF-NO2** Two front towing devices
 - RFEC-B** Rear frame end, bent down - standard for tractor vehicles
 - TOWR-ONE** Towing hitch attached to rear crossmember
 - TREL15** Single 15 pole electrical trailer connector - ADR certified
 - TREL7** 7 pole - 24N trailer electrical suzie
 - TREL7-7** 24N and 24S trailer electrical suzies
 - TBC-DUO** Duomatic type air line connectors
 - TBC-EC** Palm coupling type air line connectors
 - TBC-GBR** 'C' and 'CA' type air line connectors
 - TRBR-HCF** Full pressure hand controlled trailer brake
 - TRBR-STA** Stationary trailer brake control
 - TRB-STRE** Stretch Brake - Automatic low speed trailer brake activation to avoid jack-knifing and improve steerability
 - RFEND-B** Three piece EC approved rear mud wings and spray flaps
 - RFH-BAS** Basic rear wing height
 - RFH-HIG** High rear wing height - higher wing tops
 - RFH-LOW** Lower rear wing height - shallower wing tops
 - ATANK-AL** Aluminium air tanks
 - ATANK-ST** Steel air tanks
 - TL-LED** Rear lights LED
 - BLIGHT-E** Emergency brake light
- ## WHEELS & TYRES
- RT-AL** Alcoa brushed aluminium rims with standard holes for long stud fixing on all axles
 - RT-ALDP** Alcoa Dura-Bright EVO aluminium rims with standard holes long stud fixing on all axles, requires cleaning with a ph neutral solution - washing up liquid.
 - RT-ALDPD** Alcoa Dura-Bright EVO aluminium rims with countersunk holes for short stud fixing on all axles, requires cleaning with a ph neutral solution - washing up liquid.
 - RT-ALDU** Alcoa brushed aluminium rims with countersunk holes for short stud fixing on all axles
 - RT-SPOKE** Spoke rims on all axles
 - RT-STEEL** Steel rims on all axles
 - WCAP** Aerodynamic hub caps
 - BRREC001** Bridgestone ECOPIA H - Energy rating C
 - BRREC002** Bridgestone Ecopia H 002 Evo - Tyre recommendation 2
 - COREC001** Continental ECOPLUS HS3 XL/HD3 - Energy rating B or C depending on size
 - COREC002** Continental ECOPLUS HS3/HD3 - Energy rating B or C depending on size
 - COREC003** Continental Efficient Pro S/D - Fuel Tyre Recommendation 3 Reduced mileage compared to Conti EcoPlus long haul pattern please consider when selecting these tyres.
 - GYREC003** Goodyear FUELMAX S/(O)/D - Fuel tyre Recommendation 3
 - GYREC004** Goodyear FUELMAX S - Energy rating B depending on size
 - HAREC001** Hankook AL10+ E-Cube Max Long Haul Tyre - Energy rating B
 - HAREC002** Hankook AL10+ E-Cube Long Haul Tyre - Energy rating B with wide single
 - MIREC001** Michelin XFA2/X-LINE Energy - Fuel tyre Recommendation 1
 - MIREC002** Michelin XZA2/X-LINE Energy - Fuel tyre Recommendation 2
 - MIREC003** Michelin X-LINE Energy - Fuel tyre Recommendation 3
 - MIREC004** Michelin X Line Energy F/D2 - Energy rating A
 - PIREC001** Pirelli FH:01 Proway - Long Haul Tyre - Energy rating B
 - PIREC002** Pirelli FH:01 II Long Haul Tyre - Energy rating B with wide single
 - SPWT-D** Spare wheel & tyre with rear tyre pattern
 - SPWT-F** Spare wheel & tyre with front tyre pattern
 - SWCP-LF** Spare wheel carrier on left side of chassis ahead of rear axle
 - SWCP-T** Spare wheel supplied temporarily strapped to chassis
 - SWCP-TP** Temporary spare wheel carrier on top of chassis frame
 - JACK-12T** 12 tonne bottle jack
 - JACK-15T** 15 tonne bottle jack
 - JACK-20T** 20 tonne bottle jack
 - TOOL-BAS** Basic Toolkit
 - TOOLKIT** Complete tool kit
 - INFLAHOS** Tyre inflation hose
 - GAUGE-TP** Tyre pressure gauge
- ## DRIVELINE EQUIPMENT
- ASO-C** Crawler gear -
Ratio direct top gearbox 19:1
Ratio Overdrive gearbox 17:1
 - ASO-ULC** Ultra low crawler and crawler gear -
Ratios direct top gearbox 32:1 and 19:1
Ratios Overdrive box 32:1 and 17:1
 - TRAP-HD** Reinforced gearbox application
 - TP-CON** Construction Package
 - TP-DIST** Distribution Package
- Standard Equipment Optional Equipment

For more detailed information about cab and powertrain equipment, please refer to separate specification sheets.

For all possible options and combinations of options please consult your Volvo sales contact who can create a specification to match your requirements using the Volvo Sales Support system (VSS).

The factory reserves the right to modify design and change equipment without previous notification. The specification can vary from country to country.

MODEL RANGE

FM 13 6x4 Tractor - High B Ride - N3 Cranked front axles for on road work FM 64 T3HB

- | | |
|--|--|
| <ul style="list-style-type: none"> <input type="checkbox"/> TP-HD I-shift software - Heavy duty for high GCW
Special conditions apply consult Sales Engineering <input type="checkbox"/> TP-LONG Long Haul Package <input type="checkbox"/> AMSO-AUT Enhanced I-shift software with manual shift available in auto mode and kickdown facility on accelerator pedal <input type="checkbox"/> AVO-ENH Enhanced software for off road driveability and starting <input type="checkbox"/> APF-ENH I-shift enhanced PTO functions <input type="checkbox"/> RET-TH Gearbox mounted retarder <input type="checkbox"/> RET-TPT Hydraulic Retarder for Powertronic gearbox <input type="checkbox"/> TC-HWO Automatic gearbox oil cooler - water to oil <input type="checkbox"/> TC-MAOH2 Extra high performance transmission oil cooler - air to oil with front mounted radiator <input type="checkbox"/> TC-MWO Basic transmission oil cooler - water to oil <input type="checkbox"/> 1COMP530 Single cylinder, air compressor, 530 litres per minute <input type="checkbox"/> 2COM1100 Two cylinder, air compressor, 1100 litres per minute <input checked="" type="checkbox"/> 2COMP900 Two cylinder, air compressor, 900 litres per minute <input type="checkbox"/> CLU-AIRC Clutchable air compressor <input checked="" type="checkbox"/> AIRIN-HI Roof mounted air intake behind cab on left hand side <input type="checkbox"/> AIRIN-LO Low level air intake behind cab on left hand side <input type="checkbox"/> ACL1ST-S Two stage air filter <input checked="" type="checkbox"/> 24AL110B 110 amp alternator <input type="checkbox"/> 24AL120B 120 amp alternator <input type="checkbox"/> 24AL150B 150 amp alternator <input checked="" type="checkbox"/> CCV-C Closed crankcase engine ventilation <input type="checkbox"/> CCV-O Open crankcase engine breather <input type="checkbox"/> CCV-OX Closed crankcase ventilation for cold markets <input checked="" type="checkbox"/> PRIM-EL Electrical priming pump <input type="checkbox"/> PRIM-MAN Manual priming pump <input type="checkbox"/> FUEQ-EH Fuel line electric heater <input type="checkbox"/> AF-R Hot fuel recirculation heated fuel filter <input type="checkbox"/> FUEFE2LW Large engine mounted dual fuel filter with water separator <input checked="" type="checkbox"/> FUEFE2SW Small engine mounted dual fuel filter with water separator <input type="checkbox"/> EST-AID Air inlet manifold starting heater element <input type="checkbox"/> 220EBH15 220V/1.5Kw electric engine block heater <input type="checkbox"/> PTER-100 Rear engine mounted power-take-off with DIN 100 / ISO 7646 flange <input type="checkbox"/> PTER-DIN Rear engine mounted PTO with DIN5462 (female) splined shaft for a close coupled pump.
Models with 3 steering axles will use this to drive the steering pump (AUXPSP) <input type="checkbox"/> PTER1400 Rear engine mounted power-take-off with SAE 1410 flange <input type="checkbox"/> HPE-F101 Parker F1-101, engine mounted, fixed displacement, single flow, engine mounted hydraulic pump <input type="checkbox"/> HPE-F41 Parker F1-41, engine mounted, fixed displacement, single flow, engine mounted hydraulic pump <input type="checkbox"/> HPE-F51 Parker F1-51, engine mounted, fixed displacement, single flow, engine mounted hydraulic pump <input type="checkbox"/> HPE-F61 Parker F1-61, engine mounted, fixed displacement, single flow, engine mounted hydraulic pump <input type="checkbox"/> HPE-F81 Parker F1-81, engine mounted, fixed displacement, single flow, engine mounted hydraulic pump <input type="checkbox"/> HPE-T53 Parker F2-53/53, engine mounted, Fixed displacement, Twin flow engine mounted hydraulic pump <input type="checkbox"/> HPE-T70 Parker F2-70/35, engine mounted, Fixed displacement, Twin flow engine mounted hydraulic pump <input type="checkbox"/> HPE-V45 Parker VP1-45, variable displacement, single flow, engine mounted hydraulic pump <input type="checkbox"/> HPE-V75 Parker VP1-75, variable displacement, single flow, engine mounted hydraulic pump <input type="checkbox"/> PTPT-D Powertronic PTO, 1 front/upper DIN connection for plug-in pump (max. 850 Nm) <input type="checkbox"/> PTPT-F Powertronic PTO, 1 front/upper rear facing SAE flange conn. for prop shaft (max.850 Nm) <input type="checkbox"/> PTR-D Gearbox PTO for plug-in pump, 0.71xeng speed | <ul style="list-style-type: none"> <input type="checkbox"/> PTR-DH Gearbox driven high speed PTO for one plug-in hydraulic pump <input type="checkbox"/> PTR-DM Gearbox driven medium speed PTO for one plug-in hydraulic pump <input type="checkbox"/> PTR-F Gearbox driven PTO with rear flange connection <input type="checkbox"/> PTR-FH Gearbox driven high speed PTO with SAE drive flange <input type="checkbox"/> PTR-FL Gearbox driven low speed PTO with SAE drive flange <input type="checkbox"/> PTRD-D Gearbox driven HIGH SPEED PTO for two plug-in hydraulic pumps <input type="checkbox"/> PTRD-D1 PTRD-D1 Gearbox driven HIGH SPEED PTO (1 SAE flange & 1 plug-in hydraulic pump) <input type="checkbox"/> PTRD-D2 Gearbox driven HIGH SPEED PTO (2 SAE flanges & 1 plug-in hyd pump) <input type="checkbox"/> PTRD-F PTO with 1 DIN + 1 flange connection rear, manual gearbox <input type="checkbox"/> HPG-F101 Parker F1-101 gearbox mounted, fixed displacement, single flow, hydraulic pump <input type="checkbox"/> HPG-F41 Parker F1-41 gearbox mounted, fixed displacement, single flow, hydraulic pump <input type="checkbox"/> HPG-F51 Parker F1-51 gearbox mounted, fixed displacement, single flow, hydraulic pump <input type="checkbox"/> HPG-F61 Parker F1-61 gearbox mounted, fixed displacement, single flow, hydraulic pump <input type="checkbox"/> HPG-F81 Parker F1-81 gearbox mounted, fixed displacement, single flow, hydraulic pump <input type="checkbox"/> EIDLESD Engine idle shut down <input type="checkbox"/> DTRI-PER Dashboard in darker peregrine greyish brown. Steering wheel grey and door panels in light beige for FH and black for FH16. <input checked="" type="checkbox"/> STWPOS-R RIGHT HAND DRIVE <input type="checkbox"/> STWM-LE Leather steering wheel <input type="checkbox"/> STGW-AD2 Adjustable steering wheel with neck tilt <input checked="" type="checkbox"/> STGW-ADJ Adjustable steering wheel <input checked="" type="checkbox"/> AIRBAG SRS Driver's air bag <input checked="" type="checkbox"/> DRC-AMII DPF Regeneration control switch - for manual and switching off regeneration <input checked="" type="checkbox"/> 1DAYDIG2 Continental VDO DTCO 4.0 smart tachograph
This tachograph can ONLY offer remote download if the option of Dynafleet or an FMS gateway has been specified with this order. <input type="checkbox"/> 1DAYDIGP Continental VDO DTCO 3.0 digital tachograph
For vehicles with long lead time - this includes prep kit for the retrofit of DTCO 4.0 tachograph.
For updating to new legal demand for trick registration from 15th June 2019.
This tachograph can ONLY offer remote download if the option of Dynafleet or an FMS gateway has been specified with this order. <input type="checkbox"/> ARSL Additional road speed limit - switch in dashboard <input type="checkbox"/> CRUIS-E Eco cruise control (with eco-roll and I-cruise, controls in steering wheel)
Cruise control, standard <input checked="" type="checkbox"/> CRUISEC <input checked="" type="checkbox"/> ESP-BAS1 Electronic Stability Control <input type="checkbox"/> ESPC-RO ESP (Electronic Stability Program) functionality control - Reduced / Off <input type="checkbox"/> HWSS-ACB Adaptive cruise control ACC with forward collision warning and AEBS advanced emergency brake system <input checked="" type="checkbox"/> HWSS-FCB Forward collision warning with AEBS advanced emergency brake system <input checked="" type="checkbox"/> LSS-DW Lane departure-warning system <input type="checkbox"/> LCS Lane change support <input type="checkbox"/> DAS-W Driver Alert Support system <input type="checkbox"/> RSENS-W Rain sensing windscreen wipers <input type="checkbox"/> CU-ECC Electrically controlled air conditioning with sun sensor |
|--|--|
- Standard Equipment Optional Equipment

For more detailed information about cab and powertrain equipment, please refer to separate specification sheets.

For all possible options and combinations of options please consult your Volvo sales contact who can create a specification to match your requirements using the Volvo Sales Support system (VSS).

The factory reserves the right to modify design and change equipment without previous notification. The specification can vary from country to country.

MODEL RANGE

FM 13 6x4 Tractor - High B Ride - N3 Cranked front axles for on road work FM 64 T3HB

- CU-ECC2** Electrically controlled air conditioning with sun sensor, mist sensor, air quality sensor and carbon filter
- CU-MCC** Climate unit with manual controlled air conditioning
- IMMOBIL** Thatcham H2 approved immobiliser
- ALARM-B** Thatcham H1 approved vehicle alarm - Cab only
- ALARM-E** Enhanced vehicle alarm - Thatcham H1 approved - Cab plus external sensor for body/trailer
- ALCOLOCK** Alcolock
- BUPMON** Back up monitor with built in 7" screen on dash and one colour camera supplied loose for fitment by bodybuilder. Can accommodate up to 4 cameras for TfL Safe Scheme, CLOCS and FORS.
- PHONE-PK** Telephone preparation kit (antenna, antenna attachm. cable incl.)
- WLIFT-AD** Electrical window lift, automatic up/down driver side
- WLIFT-EB** Electrical window lift
- WLIFT-ME** Mechanical window lift
- ISUNS-BS** Side interior sun visor on both sides
- ISUNS-DS** Driver's side interior sun visor
- ISUNF-B** Interior front sun visor without mirror
- ISUNF-MD** Interior front sun visor with mirror on driver side
- ISUNF-RE** Electrically operated textile interior sun blind
- ISUNF-RM** Manually operated textile interior sun blind
- CSPU-S** One open storage (behind push open lid) in upper part of dash panel center section
- ADFS** Two extra DIN slots in front shelf - can be fitted with card or drawer available as an accessory
- BUPALARM** Reverse alarm
- RTOLL-PK** Road toll PREPARATION kit for trucks operating with "Toll Collect" in Germany
- REMC-MF** Multi-functio wireless remote control
- FIREXT3S** 3kg fire extinguisher mounted on seat base
- WARNEVEST** High visibility warning vest - no sleeves
- AIDKIT** First aid kit
- AIDKIT1B** First aid kit
- WARNLAMP** Portable warning lamp
- LAMP-IN** Inspection lamp
- BULBKIT** Bulb and fuse kit
- WRITEPAD** Writing pad
- UPHTRI10** Seats: Black embossed textile insert with light grey sides, black vinyl side bolster with blue vinyl side insert. Interior trim: Raven black bunk and curtains & blue textile side walls
- UPHTRI11** Seats: Light grey embossed textile insert, black raven metallic vinyl bolster with red vinyl side insert. Interior trim: Raven black bunk and curtains & grey vinyl side walls
- UPHTRI12** Seats: Blue soft textile insert, black vinyl bolster. Interior trim: Raven black bunk and curtains & blue textile side walls
- UPHTRI13** Seats: Dark grey leather insert and black leather bolster. Interior trim: Raven black bunk and curtains & grey vinyl side walls
- UPHTRI14** Seat: Dark grey leather insert and black leather bolster. Interior trim: Raven black bunk and curtains & blue textile side walls
- DST-CF4** Driver seat, comfort, suspended, belt in seat
- DST-CF5** Driver seat, comfort, suspended, belt in seat, electrically heated
- DST-CF6** Driver seat, comfort, suspended, belt in seat, electrically heated, ventilated
- SBD-RED** Red seat belts
- SBPRE-DS** Driver seat belt pretensioner
- PST-BAS1** Passenger seat - Fixed non suspended fold up with seatbelt mounted in cab
- PST-BENC** Bench passenger seat
- PST-CF4** Passenger seat - Comfort suspended with seatbelt mounted in seat
- PST-CF5** Passenger seat - Comfort suspended & heated with seatbelt mounted in seat
- SBPRE-PS** Passenger seat belt pretensioner
- ARM-DBPS** Two armrests on driver seat and one (outer) on passenger seat
- ARMRE-BB** Two armrests on both driver and passenger seat.
- ARMRE-DB** Two armrests, on driver seat only
- ARMRE-PB** Two armrests, on passenger seat only
- ARMRE-PS** Single armrest (next to driver) on passenger seat
- ARU-BAS** Vinyl upholstered armrest
- ARU-LEA** Leather upholstered armrest
- FMAT-RUB** Rubber floor mats
- FMAT-TX2** Textile and rubber floor mats
- LBK-RES** Foldable rest bunk
- LBK70** Lower bunk 700 x2000 mm, fixed
- ULBK** Without lower bunk
- MATL-FI** Firm lower bunk pocket sprung mattress
- MATL-SF** Lower flexizone mattress - semi-firm, pocket springs up to 100kg - 16 stone
- MATL-SO** Lower flexizone mattress - soft, pocket springs up to 85kg - 13.5 stone
- OLMAT-BA** 35mm mattress overlay protector
- OLMAT-PR** 50mm premium mattress overlay protector
- TBK60F** Fixed foldable top bunk 600 x 1900mm
- TBK70F** Fixed foldable top bunk 700 x 1900mm
- PH-CAB2** 1.8kW Air to air night heater
- PH-ENGCA** Engine and cab night heater
- PH-SS** Short stop heater
- SLCP-BAS** Basic sleeper control panel - includes interior light, parking heater, roof hatch and door lock
- SAFE** Safe box for driver's personal items
- ETSB-F** Storage on engine tunnel - on front top
- ETSB-FR** Storage on engine tunnel - on front top and at rear cab wall
- ETSB-FRS** Storage on engine tunnel - on front top & at rear cab wall & storage recessed into tunnel on right hand side
- ETSB-FS** Storage on engine tunnel - on front top and storage recessed into tunnel on right hand side
- ETSB-R** Storage on engine tunnel - box at rear cab wall
- ETSB-RS** Storage on engine tunnel - at rear cab wall and storage recessed into tunnel on right hand side
- ETSB-S** Storage on engine tunnel - recessed into tunnel on right hand side
- RUS-BAS** Rear cab upper storage 154 litres - 300 mm high
- RUS-HIG** Rear cab upper storage 245 litres - 440 mm high
- TABLE** Folding and height adjustable table - on lower bunk
- REF-ICPK** Fridge: engine tunnel mounted preparation kit
- REFR-RUS** Fridge: 28 litre rear upper wall mounted with dividers
- MICRO-PK** Preparation kit for microwave oven (wiring)
- BOTH-D** One bottle holder under dashboard centre section
- COFMA-PK** Coffee maker, preparation kit.
- INLI-BAS** Interior white LED lights - basic
- INLI-NL** Interior white and red night LED light with no dimmer
- INLI-NLD** Interior white and red night LED light with dimmer
- ARL-FLEX** Two flexible reading lamps (snake lamps)
- RH-ECS** Glass roof & escape hatch - Electrically operated
- RH-EE** Without roof hatch -Tinted glass emergency exit ONLY

Standard Equipment

Optional Equipment

For more detailed information about cab and powertrain equipment, please refer to separate specification sheets.

For all possible options and combinations of options please consult your Volvo sales contact who can create a specification to match your requirements using the Volvo Sales Support system (VSS).

The factory reserves the right to modify design and change equipment without previous notification. The specification can vary from country to country.

MODEL RANGE

FM 13 6x4 Tractor - High B Ride - N3 Cranked front axles for on road work FM 64 T3HB

- | | |
|---|---|
| <ul style="list-style-type: none"> <input type="checkbox"/> RH-ETR Glass roof & escape hatch - Electrically operated, tinted glass with rear opening <input type="checkbox"/> RH-MSR Steel roof & escape hatch - Manually operated with rear opening <input type="checkbox"/> RH-MTR Glass roof & escape hatch - Manually operated, tinted glass with rear opening ■ URH Without roof hatch <input type="checkbox"/> SWIND-BS Extra side window on both sides behind "B" pillar <input type="checkbox"/> SWIND-PS Rear side window, passenger side <input type="checkbox"/> VANMIR Vanity mirror in front shelf <input type="checkbox"/> AS-FUS Extra shelf in front upper storage compartments <input type="checkbox"/> INFOT-PK Preparation kit for the mounting of a flat screen TV in cab above the driver's door, includes bracket, electrical and speaker connections | <ul style="list-style-type: none"> ■ FOGL-WC Front fog lights <input type="checkbox"/> CL-STAT Static corner lights <input type="checkbox"/> ASL-RF2 Two Hella H11 70W spotlamps in sign box - only available with the basic headlight and no lower driving lights. <input type="checkbox"/> ASL-RFPK Preparation kit for two spotlamps in sign box <input type="checkbox"/> BEACOA2F Two front roof mounted amber beacon rotating warning lamps <input type="checkbox"/> BEACOA2R Two rear roof mounted (on accessory bracket) amber beacon flashing warning LED lamps <input type="checkbox"/> BEACON-P Roof beacon wire preparation <input type="checkbox"/> BEACONA4 Four roof mounted (2 front/2 rear) amber beacon rotating warning lamps <input type="checkbox"/> CABPT-R1 Single outlet for roof mounted accessories ■ CABPT-R2 Twin outlets for roof mounted accessories. <input type="checkbox"/> SPOTP-F Spotlamp preparation in front, max 280W <input type="checkbox"/> SPOTP-R Spotlamp preparation on roof, max 280W <input type="checkbox"/> SPOTP-RF Spotlamp preparation on cab roof and in cab front, max 2x280W <input type="checkbox"/> ROS-IL2 Preparation kit for illuminated roof sign with switch loose in cab, fit after registration <input type="checkbox"/> CSGN-GTR "Globetrotter" headboard logo ■ HORN-F1S Single tone Jericho air horn chassis mounted <input type="checkbox"/> HORN-R2S Two roof mounted air horns <input type="checkbox"/> ANT-CBR Roof mounted antenna for CB radio, single aerial <input type="checkbox"/> ACCBR-AP Front, middle & rear roof mounted accessory brackets <input type="checkbox"/> ACCBR-F Front roof mounted accessory bracket <input type="checkbox"/> ACCBR-FM Front & middle roof mounted accessory brackets <input type="checkbox"/> ACCBR-FR Front & rear roof mounted accessory brackets <input type="checkbox"/> ACCBR-M Middle roof mounted accessory bracket <input type="checkbox"/> ACCBR-R Rear roof mounted accessory bracket <input type="checkbox"/> ACCBR-RM Rear & middle roof mounted accessory brackets <input type="checkbox"/> LADDER Ladder back of cab <input type="checkbox"/> REFS-TW White cab conspicuity markings by packed in cab <input type="checkbox"/> REFS-TY Yellow cab conspicuity markings by packed in cab |
|---|---|
- CAB EXTERIOR**
- | | |
|--|--|
| <ul style="list-style-type: none"> <input type="checkbox"/> PAICS-B Basic cab paint - mirrors, sunvisor, instep and bumper supplied in natural finish - grey <input type="checkbox"/> PAICS-C Complete cab - mirrors, insteps, sunvisor, and bumper finished in cab colour ■ GLAS-TIN Tinted windows. <input type="checkbox"/> AWIND-RF Rear window <input type="checkbox"/> DGLAS-L Laminated door glass ■ LOCK-MAN Manual door locking <input type="checkbox"/> LOCK-MRP Manual door locking with internal remote control (from driver side) of passenger door <input type="checkbox"/> LOCK-REM Central locking with remote control <input type="checkbox"/> BUMP-B Plastic front bumper ■ BUMP-B2 Steel front bumper <input type="checkbox"/> BUMP-SP Front bumper spoiler <input type="checkbox"/> GUARD-EH Engine guard to protect sump and engine hoses ■ BUGNET Insect screen in front of radiator <input type="checkbox"/> CTILT-P-E Electrically operated hydraulic cab tilt ■ CTILT-P-M Manually operated hydraulic cab tilt <input type="checkbox"/> FCABS-A Front cab suspension - Air ■ FCABS-M Front cab suspension - Mechanical spring <input type="checkbox"/> RCABS-A Rear cab suspension - Air ■ RCABS-M Rear cab suspension - Mechanical spring <input type="checkbox"/> MIRCOMF2 Electrically heated and operated FMX style main and wide-angle mirror on both sides, with manual passenger kerb mirror. To increase direct vision to the side the main mirrors have no cowlings <input type="checkbox"/> MIRCOMFM Electrically heated and operated main with manual wide-angle mirror - both sides - and passenger kerb mirror <input type="checkbox"/> MIRSTD2 Electrically heated - FMX - main with wide angle mirror on both sides and kerb view mirror on passenger side, to increase direct vision to the side the main mirrors have no cowlings ■ MIRSTDFM Electrically heated main mirror with wide angle mirror on both sides and kerb view mirror on passenger side ■ AMIR-F20 Auxiliary front view mirror with a 200mm radius <input type="checkbox"/> SUNV-H External smoke grey sunvisor <input type="checkbox"/> AD-ROOF Roof air deflector <input type="checkbox"/> AD-SIDEL Side air deflector extension panels <input type="checkbox"/> AD-SIDES Short cab side air deflector for rigid bodywork ■ HL-BASIC Halogen H7 head lamps <input type="checkbox"/> HL-CLEAN Head lamp cleaner - washer jets <input type="checkbox"/> HLP-ST Headlamp protection ■ HL-ADJ Headlight adjustment - Switch in cab <input type="checkbox"/> DRIVL2 Two spot lamps ■ UDRIVL Without auxiliary driving lights | <ul style="list-style-type: none"> ■ 5WM-ISOH 5th wheel subframe 90mm high above chassis frame ■ 5WM-ISOM 5th wheel subframe 60mm high above chassis frame L profiles 50mm with 10mm thick plate <input type="checkbox"/> 5WM-MASM 50mm high 'L' profiles for manual sliding fifth wheel <input type="checkbox"/> 5WH150 Fifth wheel leg-height 150 mm <input type="checkbox"/> 5WH185 Fifth wheel leg-height 185 mm <input type="checkbox"/> 5WH190 Fifth wheel leg-height 190 mm <input type="checkbox"/> 5WH290 Fifth wheel leg-height 290 mm <input type="checkbox"/> 5WT-JO11 Jost JSK 38G cast heavy duty fixed fifth wheel ■ 5WT-JO8 Jost JSK 37 cast fifth wheel <input type="checkbox"/> 5WT-JO9 Jost JSK 42 cast fixed fifth wheel <input type="checkbox"/> 5WT-JOHD Jost JSK 38C cast heavy duty fifth wheel <input type="checkbox"/> 5WT-SH SAF-Holland/+GF+ SK-S 36.20 cast fixed fifth wheel <input type="checkbox"/> 5WT-SH2 SAF-Holland/+GF+ SK-HD 38.36 cast heavy duty fixed fifth wheel <input type="checkbox"/> 5WL-S1 Fifth wheel lubrication - locking mechanism and top plate <input type="checkbox"/> TCIND Trailer connection indication with sensors for height, kingpin and coupling lock <input type="checkbox"/> RDECK Catwalk & step <input type="checkbox"/> RDECK-M Rear catwalk 760mm <input type="checkbox"/> SRWL-PK Wiring preparation for side & rear work/reverse lamps on side of chassis and a three-position switch, maximum 280W <input type="checkbox"/> SWL-2RA Two H3 35W amber rear chassis mounted (LH/RH side) working lamps and a 2-position switch (On/Off) <input type="checkbox"/> SWL-2RW Two H3 70W white rear chassis mounted (LH/RH side) working lamps and a 2-position switch (On/Off) <input type="checkbox"/> SWL-PK Wiring preparation for side work/reverse lamps on side of chassis and a three-position switch, maximum 280W |
|--|--|

■ Standard Equipment □ Optional Equipment

For more detailed information about cab and powertrain equipment, please refer to separate specification sheets.

For all possible options and combinations of options please consult your Volvo sales contact who can create a specification to match your requirements using the Volvo Sales Support system (VSS).

The factory reserves the right to modify design and change equipment without previous notification. The specification can vary from country to country.

MODEL RANGE

FM 13 6x4 Tractor - High B Ride - N3 Cranked front axles for on road work FM 64 T3HB

- **WL-TA1W** White coupling light
- **WLC-H2A** Two H3/70W working lamps with amber coloured lens high mounted back of cab
- **WLC-H2W** Two H3/70W white working lamps high mounted on the back of cab
- **WLC-PKH** Preparation kit, cables and switch for high mounted working lamps back of cab
- **WLC-PKL** Preparation kit, cables and switch for low mounted working lamps back of cab
- **WLC-PKLH** Preparation kit - cables and switch for low and high mounted working lamps back of cab.

- **ECBB-BAS** Body builder electrical centre without body builder module
- **ECBB-HIG** Body builder electrical centre with body builder module
- **BBCHAS1** One 7-pole connector for Body builder interface
- **BBCHAS3** Three 7-pole connectors for Body builder interface
- **BEPR-T2** Body builder electrical software preparation for tipper with remote control

- **EXSTER** External steering control, with VDS and bodybuilder module
- **TD-BAS** Trailer detection WITHOUT LED sensing
- **TD-LED** Trailer detection with LED sensing

- **AUXL-SPK** Electrical preparation kit - wiring and switch for snow plough lights

- **TAILPRE2** Tail lift preparation kit, wireless remote operation
- **TAILPREP** Taillift preparation kit - cab switch and warning in driver display

- **AESW2** Two Body builder bistable electrical switches (marked AUX1 / AUX2)
- **AESW2PK** 2 Body builder bistable el.switches (marked AUX1/AUX2) and prep. for 4 more switches

- **AUXSW-4** Wiring for 4 extra switches (from Body builder electrical centre to switch positions)

DELIVERY SERVICES

- **TGW-4GWL** GSM/GPRS/4G modem, LTE & WLAN for telematics gateway
- **FMS-PK** Fleet Management System gateway

VOLVO

Volvo Truck Corporation

volvotrucks.com