

MODEL RANGE

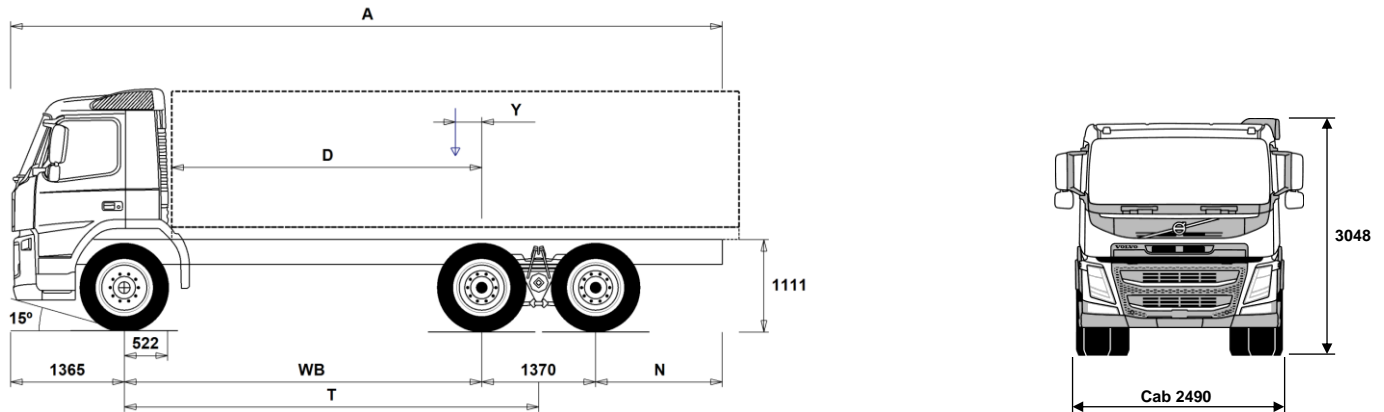

Volvo Trucks. Driving Progress

FM 13 6x4 Rigid - High T Ride - N3 Cranked front axle for on road work FM 64 R3HT



Chassis Dimensions [mm]

WB Wheelbase	3400	3700	3900	4300	4600	4900	5200	5600
A Overall Chassis Length	8010	8460	8760	9410	9860	10310	10810	11410
D Center of rear axle to front of body	2828	3128	3328	3728	4028	4328	4628	5028
N Rear Overhang (Min.)	1225	1225	1225	1225	1225	1225	1225	1225
N Rear Overhang (Max.)	1875	2025	2125	2375	2525	2675	2875	3075
T Theoretical Wheelbase	4085	4385	4585	4985	5285	5585	5885	6285
Y Center of Gravity for Payload (Min.)	-85	-44	-17	37	76	114	155	205
Y Center of Gravity for Payload (Max.)	145	203	241	319	377	433	491	566

Chassis Weights [kg]

Front Axle	4380	4400	4415	4440	4460	4490	4505	4535
Rear Bogie	3815	3840	3855	3905	3935	3980	4010	4055
Kerb Weight	8195	8240	8270	8345	8395	8470	8515	8590
Payload (including body, driver, fuel, etc.)	17805	17760	17730	17655	17605	17530	17485	17410

Turning Diameter [mm]

Turning Circle Diameter Kerb to Kerb	14500	15500	16100	17300	18200	19100	20000	21300
Turning Circle Diameter Wall to Wall	16000	16900	17500	18700	19700	20600	21500	22700

Plated Weights [kg]

	Plated	Design
Gross Vehicle Weight	26000	34000
Gross Combination Weight	44000	44000
Front Axle	8000	8000
Rear Bogie	19000	26000

Important Notes

Chassis Dimensions

Cab Height: +416 mm for CAB-HSLP, -169 mm for CAB-LSLP.
Front Axle to Back of Cab: +424 mm for CAB-HSLP and CAB-SLP, +418 mm for CAB-LSLP.

D-measure includes a front clearance of 50 mm and for rigid trucks also a subframe of 100 mm.

Height can vary ± 20 mm for leaf and ± 10 mm for air suspension.

All dimensions are for unladen chassis and any tag axles down.

Rear overhang used for vehicle weight calculation is the maximum rear overhang (N Max.) for selected wheelbase.

Weight and dimensions are based upon the following tyres:

Front Axle Tyres: 315/80R22.5
Drive Axle Tyres: 315/80R22.5

Chassis weight includes oil, water, AdBlue, 0 litres fuel and without driver. Kerb weight can vary $\pm 3\%$.

Turning diameters are theoretically calculated.

Legal weights can differ from country to country.

For more detailed weight information, including optional equipment weights, ask your Volvo sales contact to enter your specification into the Volvo Weight Information system (WIS).

Do NOT use this drawing for bodybuilding. Refer to Volvo Bodybuilder Instructions and chassis assembly drawing FM64R3HT.

MODEL RANGE

FM 13 6x4 Rigid - High T Ride - N3 Cranked front axle for on road work FM 64 R3HT

TRUCK USE

- PTO-HT16** High torque power take-off up to 1600Nm
- PTO-HT20** High torque power take-off up to 2000Nm
- RC-ROUGH** Operating class on/off road
- RC-VROUG** Very rough road conditions
- TIPP-PRE** Tipper vehicle preparation
- UNIFORM** Basic platform vehicle

CORE COMPONENTS

- CHH-HIGH** Chassis height high - N3 "On Road" chassis - For a specific loading height always check the unique BEP chassis drawing
- RADD-TR1** T-ride 1 rear two spring bogie suspension, 75mm wide springs
- RADD-TR2** T-ride 3 rear two spring bogie suspension, reinforced
- FM-DAY** Day cab - with steel safety cage design
Designed and built to Swedish impact and ECE R29 regulations
- FM-HSLP** Globetrotter cab - with steel safety cage design
Designed and built to Swedish impact and ECE R29 regulations
- FM-LSLP** Low sleeper cab - with steel safety cage design
Designed and built to Swedish impact and ECE R29 regulations
- FM-SLP** Sleeper cab - with steel safety cage design
Designed and built to Swedish impact and ECE R29 regulations
- EU6SCR** Emission level - Euro 6
- D13 420S** D13K420 12.8 litre engine developing 420hp at 14-1800rpm.
Peak torque 2100Nm at 860 -1400rpm.
- D13 460S** D13K460 12.8 litre engine developing 460hp at 14-1800rpm.
Peak torque 2300Nm at 900-1400rpm.
- D13 500S** D13K500 12.8l engine developing 500hp at 14-1800rpm.
Peak torque 2500Nm at 1000-1400rpm.
- D13K420** D13K420 - 420hp engine
- D13K460** D13K460 - 460hp engine
- D13K500** D13K500 - 500hp engine
- EBR-EPG** Exhaust brake controlled by steering column switch
- EBR-EPGC** Exhaust pressure governor for I shift gearbox
- EBR-VEB+** Volvo engine brake + and exhaust pressure governor, enhanced performance from additional exhaust rocker control. Retardation 375kW
- AT2612F** AT2612F 12-speed "I-shift" automated mechanical gearbox suitable for gross train weights up to 60tonne only refer to sales engineering when used in conjunction with a PTO
- ATO2612F** ATO2612F 12-speed "I-shift" overdrive automated mechanical gearbox suitable for gross train weights up to 60tonne refer to sales engineering when used in conjunction with a PTO
- PT2606** Powertronic automatic 6-speed gearbox, max. engine torque 2600 Nm, max. permitted GCW 130000 kg
- SPO2812** SPO2812 - 12 speed I-shift Dual Clutch automated mechanical gearbox GCW 60tonne
- RTH2610F** RTH2610F hub reduction tandem 26tonne drive axles, GCW 100 tonnes with differential and cross locks*
* Cross locks replaced by a dog clutch if tandem axle lift is specified
- RTH3210F** RTH3210F hub reduction tandem 32 tonne drive axles, GCW 100 tonnes with differential and cross locks*
* Cross locks replaced by a dog clutch if tandem axle lift is specified
- RTH3312** RTH3312 hub reduction tandem 33tonne drive axles, GCW 120 tonnes with differential and cross locks*
* Cross locks replaced by a dog clutch if tandem axle lift is specified
- RTS2370A** RTS2370A single reduction tandem 23tonne drive axles with differential and cross locks* - design GCW 70tonnes.
* Cross locks replaced by a dog clutch if tandem axle lift is specified.

Standard Equipment

Optional Equipment

For more detailed information about cab and powertrain equipment, please refer to separate specification sheets.

For all possible options and combinations of options please consult your Volvo sales contact who can create a specification to match your requirements using the Volvo Sales Support system (VSS).

The factory reserves the right to modify design and change equipment without previous notification. The specification can vary from country to country.

PACKAGES

- DRIVEFM** Cab Package: Drive
- DRIVEFM+** Cab Package: Drive +
- BEDFM** One bed resting package
- AUDHIG** High Power Audio system: RDS radio with CD player - also playing MP3/WMA files from CD -, with integrated bluetooth phone and USB/Line inputs. FM/AM antenna, speakers in dashboard, doors, and sleeping compartment.
- MEDIA** AM/FM Bluetooth radio without CD player. USB and Aux line inputs. Speakers in dashboard, doors, and sleeping compartment. 7" touch screen with personal apps.
- MEDIADF** AM/FM Bluetooth radio without CD player. USB and Aux line inputs. Speakers in dashboard, doors, and sleeping compartment. 7" touch screen with personal and professional apps. Dynafleet vehicle on-board data display with office internet support.
- MEDIANAV** AM/FM Bluetooth radio without CD player. USB and Aux line inputs. Speakers in dashboard, doors, and sleeping compartment. 7" touch screen with personal and professional apps. Truck based satellite navigation (live updates not included)
- MEDIANDF** AM/FM Bluetooth radio without CD player. USB and Aux line inputs. Speakers in dashboard, doors, and sleeping compartment. 7" touch screen with personal and professional apps. Truck based satellite navigation (live updates not included) Dynafleet vehicle on-board data display with office internet support.
- VISI15** Visibility Package
- RCHAPAC1** Chassis Package Rigid

CHASSIS

- FST-PAR** Front suspension type - 2 leaf parabolic springs
- FST-PAR3** Front suspension type - 3 leaf parabolic springs
- FAL10.0** Front axle design capacity 10 tonnes - Ensure that you have checked the tyre load index
- FAL7.1** Front axle design capacity 7.1 tonnes
- FAL7.5** Front axle design capacity 7.5 tonnes
- FAL8.0** Front axle design capacity 8.0 tonnes - Ensure that you have checked the tyre load index
- FAL8.5** Front axle design capacity 8.5 tonnes
- FAL9.0** Front axle design capacity 9.0 tonnes - Ensure that you have checked the tyre load index
- FSM-LUB** Lubricated rear shackles on front suspension pins and bushings
- FSTAB** Front anti-roll bar
- FSTAB2** Front anti-roll bar medium stiffness
- FSTAB3** Front stiff anti-roll bar
- RAL23** Rear bogie design capacity 23 tonnes
- RAL26** Rear bogie design capacity 26 tonnes
- RAL32** Rear bogie design capacity 32 tonnes
- RSTAB1** Rear anti-roll bar
- RSAP2** Heavy duty rear suspension application (with reinforcements)
- ACTST-TO** Volvo Dynamic Steering (VDS) with with extra electronic pump and torque overlay
- ASFE-BAS** Active steering feature - Basic - Volvo Dynamic Steering only
- ASFE-PS** Active steering feature - Volvo Dynamic Steering with personal settings
- PSS-SING** Single power steering system
- PSP-FIX** Power steering pump with fixed displacement
- PSP-VAR** Power steering pump with variable displacement
- EBS-MED** EBS medium package including "hill" hold function
- AUXPARK** Additional spring parking brakes

MODEL RANGE

FM 13 6x4 Rigid - High T Ride - N3 Cranked front axle for on road work FM 64 R3HT

- RST-MUL** Rear Suspension, Multi-leaf springs
 - RST-PAR1** Rear Suspension, Parabolic springs
 - RST-PAR5** Rear Suspension, Progressive parabolic springs
 - FBREG-E** Front regulating brake valve, EBS
 - FBREG-RP** Front regulating brake valve, reduced pressure/low pressure range
 - FRAME300** Frame rail section external height 300 mm
 - FST8080** Frame thickness - web and flange 8.0mm
 - FIL-EEEB** Inner liner from end of engine to end of bogie
 - FIL-EEEF** Inner liner from end of engine to end of frame
 - FIL-FBEB** Inner liner over rear bogie
 - FIL-FBEF** Inner liner from front of bogie to end of frame
 - FIL-TXEB** Inner liner from gearbox member to end of bogie
 - FIL-TXEF** Inner liner from gearbox member to end of frame
 - BBOX-L** Battery box located on left hand side
 - BATS-D** Dual energy battery system - 2 living batteries and 2 starter batteries.
 - 2BAT210B** 2 x 210 Ah capacity Gel batteries
 - 2BATT170** 2 x 170 Ah capacity batteries
 - 2BATT225** 2 x 225 Ah capacity batteries
 - BATTAMP** Battery voltage and ampere gauge
 - BATTIND** Battery charge indication
 - ADR2** ADR package for transportation of dangerous goods on road (Note does NOT include safe loading pass package if required this is quoted separately)
 - MSWI-A** Main switch - ADR switch circuit shut down
 - MSWI-C** Main switch - Chassis mounted toggle switch by battery box
 - MSWI-R** Main switch - Key fob operated remote controlled
 - R365A71** Right tank 365litre aluminium diameter 710mm
Min volume 255l
Max volume 885l
 - UL-FUEL** Without left fuel tank
Min volume 160l
Max volume 730l
 - ADTP-L** AdBlue tank on left hand side
 - ADTP-R** AdBlue tank on right hand side
 - ADB048** AdBlue tank usable volume 48 litres
 - ADB064** AdBlue tank usable volume 64 litres
 - ADB068** AdBlue tank usable volume 68 litres
 - ADB090** AdBlue tank usable volume 90 litres
 - FCAP-L** Locking fuel filler cap
 - FUFF-AS** Fuel filling anti-spillage device
 - FUFF-ATS** Fuel filling anti-theft and anti-spillage devices
 - ESH-LEFT** Horizontal silencer, left exhaust outlet
 - ESH-REAR** Horizontal silencer, rear exhaust outlet
 - ESH-RIGH** Horizontal silencer, right exhaust outlet
 - ESH-VERT** Horizontal silencer, vertical exhaust outlet
 - EXST-SSP** Stainless steel exhaust stack - NOT polished
 - EXST-ST** Steel exhaust stack
 - HS-NAR** Narrow heat shield
 - WHC-FIX2** Two fixed wheel chocks
 - WHC-FOL2** Two foldable wheel chocks
 - WHCP-F** Wheel chock(s) stored in the front part of the vehicle
 - WHCP-M** Wheel chock(s) stored in the middle part of the vehicle
 - WHCP-R** Wheel chock(s) stored in the rear part of the vehicle
 - WHCP-T** Transport mounted wheel chock(s) stored in cab outer luggage locker
 - TB-L80** Toolbox 800 mm, left side
 - TB-R80** Toolbox 800 mm, right side
 - SUP-BAS** EC approved chassis side guards
 - CHAIN-S** Snow chains
 - Standard Equipment**
 - Optional Equipment**
- HOOK-SC** Snow chain hooks
 - TOWF-NO1** One front towing device
 - TOWF-NO2** Two front towing devices
 - TOWMBRH** Towing member, high mounted in centre of frame, D = 190
 - TOWMBRL1** Towing member, low mounted under the frame
 - TOWMBRM** Towing member, medium mounted in line with frame lower flange
 - RFEC-L** Rear frame end, lower flange cut for centre axle drawbar.
 - RFEC-S** Rear frame end, straight cut for regular platform applications
 - RFEC-U** Rear frame end, upper cut for tipper applications.
 - C-RI4040** Towing coupling, Ringfeder 4040 G-150
 - C-RI5055** Towing coupling, Ringfeder 5055 G-150
 - C-RO400G** Towing coupling, Rockinger 400 G-150 for 40mm eyes
 - C-RO50** Rockinger RO 50 50mm for centre axle trailer
 - TOWR-ONE** Towing hitch attached to rear crossmember
 - TREL-PK** Trailer electrical preparation kit - chassis/cab wiring
 - TREL14** Single 14 pole electrical trailer connector
 - TREL15** Single 15 pole electrical trailer connector - ADR certified
 - TREL7** 7 pole - 24N trailer electrical suzie
 - TREL7-7** 24N and 24S trailer electrical suzies
 - TBC-DUO** Duomatic type air line connectors
 - TBC-EC** Palm coupling type air line connectors
 - TRBR-HCF** Full pressure hand controlled trailer brake
 - TRBR-STA** Stationary trailer brake control
 - TRB-STRE** Stretch Brake - Automatic low speed trailer brake activation to avoid jack-knifing and improve steerability
 - RUP-FOLD** Folding EC approved aluminium rear underrun
 - RUP-FOSL** Folding & sliding EC approved aluminium rear underrun
 - RFEND-B** Three piece EC approved rear mud wings and spray flaps
 - RFEND-T** Rear mud wings, transport mounted
 - RFH-BAS** Basic rear wing height
 - RFH-HIG** High rear wing height - higher wing tops
 - RFH-LOW** Lower rear wing height - shallower wing tops
 - ATANK-AL** Aluminium air tanks
 - ATANK-ST** Steel air tanks
 - REST-RUP**
 - TL-LED** Rear lights LED
 - BLIGHT-E** Emergency brake light
- ## WHEELS & TYRES
- RT-AL** Alcoa brushed aluminium rims with standard holes for long stud fixing on all axles
 - RT-ALDP** Alcoa Dura-Bright EVO aluminium rims with standard holes long stud fixing on all axles, requires cleaning with a ph neutral solution - washing up liquid.
 - RT-ALDPD** Alcoa Dura-Bright EVO aluminium rims with countersunk holes for short stud fixing on all axles, requires cleaning with a ph neutral solution - washing up liquid.
 - RT-ALDU** Alcoa brushed aluminium rims with countersunk holes for short stud fixing on all axles
 - RT-SPOKE** Spoke rims on all axles
 - RT-STEEL** Steel rims on all axles
 - WCAP** Aerodynamic hub caps
 - BRREC001** Bridgestone ECOPIA H - Energy rating C
 - BRREC002** Bridgestone Ecopia H 002 Evo - Tyre recommendation 2
 - COREC001** Continental ECOPLUS HS3 XL/HD3 - Energy rating B or C depending on size
 - COREC002** Continental ECOPLUS HS3/HD3 - Energy rating B or C depending on size
 - COREC003** Continental Efficient Pro S/D - Fuel Tyre Recommendation 3 Reduced mileage compared to Conti EcoPlus long haul pattern please consider when selecting these tyres.
 - GYREC003** Goodyear FUELMAX S/(O)/D - Fuel tyre Recommendation 3
 - GYREC004** Goodyear FUELMAX S - Energy rating B depending on size

For more detailed information about cab and powertrain equipment, please refer to separate specification sheets.

For all possible options and combinations of options please consult your Volvo sales contact who can create a specification to match your requirements using the Volvo Sales Support system (VSS).

The factory reserves the right to modify design and change equipment without previous notification. The specification can vary from country to country.

MODEL RANGE

FM 13 6x4 Rigid - High T Ride - N3 Cranked front axle for on road work FM 64 R3HT

- HAREC001** Hankook AL10+ E-Cube Max Long Haul Tyre - Energy rating B
 - HAREC002** Hankook AL10+ E-Cube Long Haul Tyre - Energy rating B with wide single
 - MIREC001** Michelin XFA2/X-LINE Energy - Fuel tyre Recommendation 1
 - MIREC002** Michelin XZA2/X-LINE Energy - Fuel tyre Recommendation 2
 - MIREC003** Michelin X-LINE Energy - Fuel tyre Recommendation 3
 - MIREC004** Michelin X Line Energy F/D2 - Energy rating A
 - PIREC001** Pirelli FH:01 Proway - Long Haul Tyre - Energy rating B
 - PIREC002** Pirelli FH:01 II Long Haul Tyre - Energy rating B with wide single
 - SPWT-D** Spare wheel & tyre with rear tyre pattern
 - SPWT-F** Spare wheel & tyre with front tyre pattern
 - SWCP-LF** Spare wheel carrier on left side of chassis ahead of rear axle
 - SWCP-R** Rear mounted spare wheel carrier
 - SWCP-T** Spare wheel supplied temporarily strapped to chassis
 - SWCP-TP** Temporary spare wheel carrier on top of chassis frame
 - JACK-12T** 12 tonne bottle jack
 - JACK-15T** 15 tonne bottle jack
 - JACK-20T** 20 tonne bottle jack
 - TOOL-BAS** Basic Toolkit
 - TOOLKIT** Complete tool kit
 - INFLAHOS** Tyre inflation hose
 - GAUGE-TP** Tyre pressure gauge
- ### DRIVELINE EQUIPMENT
- ASO-C** Crawler gear - Ratio direct top gearbox 19:1 Ratio Overdrive gearbox 17:1
 - ASO-ULC** Ultra low crawler and crawler gear - Ratios direct top gearbox 32:1 and 19:1 Ratios Overdrive box 32:1 and 17:1
 - TRAP-HD** Reinforced gearbox application
 - TP-CON** Construction Package
 - TP-DIST** Distribution Package
 - TP-HD** I-shift software - Heavy duty for high GCW Special conditions apply consult Sales Engineering
 - TP-LONG** Long Haul Package
 - AMSO-AUT** Enhanced I-shift software with manual shift available in auto mode and kickdown facility on accelerator pedal
 - AVO-ENH** Enhanced software for off road driveability and starting
 - APF-ENH** I-shift enhanced PTO functions
 - RET-TH** Gearbox mounted retarder
 - RET-TPT** Hydraulic Retarder for Powertronic gearbox
 - TC-HWO** Automatic gearbox oil cooler - water to oil
 - TC-MAOH2** Extra high performance transmission oil cooler - air to oil with front mounted radiator
 - TC-MWO** Basic transmission oil cooler - water to oil
 - 1COMP530** Single cylinder, air compressor, 530 litres per minute
 - 2COM1100** Two cylinder, air compressor, 1100 litres per minute
 - 2COMP900** Two cylinder, air compressor, 900 litres per minute
 - CLU-AIRC** Clutchable air compressor
 - AIRIN-HI** Roof mounted air intake behind cab on left hand side
 - AIRIN-LO** Low level air intake behind cab on left hand side
 - ACL1ST-S** Two stage air filter
 - 24AL110B** 110 amp alternator
 - 24AL120B** 120 amp alternator
 - 24AL150B** 150 amp alternator
 - CCV-C** Closed crankcase engine ventilation
 - CCV-O** Open crankcase engine breather
 - CCV-OX** Closed crankcase ventilation for cold markets
 - PRIM-EL** Electrical priming pump
 - PRIM-MAN** Manual priming pump
 - FUEQ-EH** Fuel line electric heater
 - AF-R** Hot fuel recirculation heated fuel filter
 - FUEFE2LW** Large engine mounted dual fuel filter with water separator
 - FUEFE2SW** Small engine mounted dual fuel filter with water separator
 - EST-AID** Air inlet manifold starting heater element
 - 220EBH15** 220V/1.5Kw electric engine block heater
 - PTER-100** Rear engine mounted power-take-off with DIN 100 / ISO 7646 flange
 - PTER-DIN** Rear engine mounted PTO with DIN5462 (female) splined shaft for a close coupled pump. Models with 3 steering axles will use this to drive the steering pump (AUXPSP)
 - PTER1400** Rear engine mounted power-take-off with SAE 1410 flange
 - HPE-F101** Parker F1-101, engine mounted, fixed displacement, single flow, engine mounted hydraulic pump
 - HPE-F41** Parker F1-41, engine mounted, fixed displacement, single flow, engine mounted hydraulic pump
 - HPE-F51** Parker F1-51, engine mounted, fixed displacement, single flow, engine mounted hydraulic pump
 - HPE-F61** Parker F1-61, engine mounted, fixed displacement, single flow, engine mounted hydraulic pump
 - HPE-F81** Parker F1-81, engine mounted, fixed displacement, single flow, engine mounted hydraulic pump
 - HPE-T53** Parker F2-53/53, engine mounted, Fixed displacement, Twin flow engine mounted hydraulic pump
 - HPE-T70** Parker F2-70/35, engine mounted, Fixed displacement, Twin flow engine mounted hydraulic pump
 - HPE-V45** Parker VP1-45, variable displacement, single flow, engine mounted hydraulic pump
 - HPE-V75** Parker VP1-75, variable displacement, single flow, engine mounted hydraulic pump
 - PTPT-D** Powertronic PTO, 1 front/upper DIN connection for plug-in pump (max. 850 Nm)
 - PTPT-F** Powertronic PTO, 1 front/upper rear facing SAE flange conn. for prop shaft (max.850 Nm)
 - PTR-D** Gearbox PTO for plug-in pump, 0.71xeng speed
 - PTR-DH** Gearbox driven high speed PTO for one plug-in hydraulic pump
 - PTR-DM** Gearbox driven medium speed PTO for one plug-in hydraulic pump
 - PTR-F** Gearbox driven PTO with rear flange connection
 - PTR-FH** Gearbox driven high speed PTO with SAE drive flange
 - PTR-FL** Gearbox driven low speed PTO with SAE drive flange
 - PTRD-D** Gearbox driven HIGH SPEED PTO for two plug-in hydraulic pumps
 - PTRD-D1** PTRD-D1 Gearbox driven HIGH SPEED PTO (1 SAE flange & 1 plug-in hydraulic pump)
 - PTRD-D2** Gearbox driven HIGH SPEED PTO (2 SAE flanges & 1 plug-in hyd pump)
 - PTRD-F** PTO with 1 DIN + 1 flange connection rear, manual gearbox
 - HPG-F101** Parker F1-101 gearbox mounted, fixed displacement, single flow, hydraulic pump
 - HPG-F41** Parker F1-41 gearbox mounted, fixed displacement, single flow, hydraulic pump
 - HPG-F51** Parker F1-51 gearbox mounted, fixed displacement, single flow, hydraulic pump
 - HPG-F61** Parker F1-61 gearbox mounted, fixed displacement, single flow, hydraulic pump
 - HPG-F81** Parker F1-81 gearbox mounted, fixed displacement, single flow, hydraulic pump
 - EIDLESD** Engine idle shut down
 - DTRI-PER** Dashboard in darker peregrine greyish brown. Steering wheel grey and door panels in light beige for FH and black for FH16.
 - STWPOS-R** RIGHT HAND DRIVE
 - STWM-LE** Leather steering wheel
 - STGW-AD2** Adjustable steering wheel with neck tilt
 - STGW-ADJ** Adjustable steering wheel
 - AIRBAG** SRS Driver's air bag

Standard Equipment

Optional Equipment

For more detailed information about cab and powertrain equipment, please refer to separate specification sheets.

For all possible options and combinations of options please consult your Volvo sales contact who can create a specification to match your requirements using the Volvo Sales Support system (VSS).

The factory reserves the right to modify design and change equipment without previous notification. The specification can vary from country to country.

MODEL RANGE

FM 13 6x4 Rigid - High T Ride - N3 Cranked front axle for on road work FM 64 R3HT

- **DRC-AMII** DPF Regeneration control switch - for manual and switching off regeneration
- **1DAYDIG2** Continental VDO DTCO 4.0 smart tachograph
This tachograph can ONLY offer remote download if the option of Dynafleet or an FMS gateway has been specified with this order.
- **1DAYDIGP** Continental VDO DTCO 3.0 digital tachograph
For vehicles with long lead time - this includes prep kit for the retrofit of DTCO 4.0 tachograph.
For updating to new legal demand for truck registration from 15th June 2019.
This tachograph can ONLY offer remote download if the option of Dynafleet or an FMS gateway has been specified with this order.
- **ARSL** Additional road speed limit - switch in dashboard
- **SPEED-DU** Dual speed limiter
- **CRUIS-E** Eco cruise control (with eco-roll and I-cruise, controls in steering wheel)
- **CRUISEC** Cruise control, standard
- **ESP-BAS1** Electronic Stability Control
- **ESPC-RO** ESP (Electronic Stability Program) functionality control - Reduced / Off
- **HWSS-ACB** Adaptive cruise control ACC with forward collision warning and AEBS advanced emergency brake system
- **HWSS-FCB** Forward collision warning with AEBS advanced emergency brake system
- **LSS-DW** Lane departure-warning system
- **LCS** Lane change support
- **DAS-W** Driver Alert Support system
- **RSENS-W** Rain sensing windscreen wipers
- **CU-ECC** Electrically controlled air conditioning with sun sensor
- **CU-ECC2** Electrically controlled air conditioning with sun sensor, mist sensor, air quality sensor and carbon filter
- **CU-MCC** Climate unit with manual controlled air conditioning
- **IMMOBIL** Thatcham H2 approved immobiliser
- **ALARM-B** Thatcham H1 approved vehicle alarm - Cab only
- **ALARM-E** Enhanced vehicle alarm - Thatcham H1 approved - Cab plus external sensor for body/trailer
- **ALCOLOCK** Alcolock
- **BUPMON** Back up monitor with built in 7" screen on dash and one colour camera supplied loose for fitment by bodybuilder.
Can accommodate up to 4 cameras for TfL Safe Scheme, CLOCS and FORS.
- **PHONE-PK** Telephone preparation kit (antenna, antenna attachm. cable incl.)
- **WLIFT-AD** Electrical window lift, automatic up/down driver side
- **WLIFT-EB** Electrical window lift
- **WLIFT-ME** Mechanical window lift
- **ISUNS-BS** Side interior sun visor on both sides
- **ISUNS-DS** Driver's side interior sun visor
- **ISUNF-B** Interior front sun visor without mirror
- **ISUNF-MD** Interior front sun visor with mirror on driver side
- **ISUNF-RE** Electrically operated textile interior sun blind
- **ISUNF-RM** Manually operated textile interior sun blind
- **ADFS** Two extra DIN slots in front shelf - can be fitted with card or drawer available as an accessory
- **BUPALARM** Reverse alarm
- **RTOLL-PK** Road toll PREPARATION kit for trucks operating with "Toll Collect" in Germany
- **LOADIND** Load indicator with central dashboard display
- **REMC-MF** Multi-function wireless remote control
- **FIREXT3S** 3kg fire extinguisher mounted on seat base
- **WARNVEST** High visibility warning vest - no sleeves
- **AIDKIT** First aid kit
- **AIDKIT1B** First aid kit
- **WARNLAMP** Portable warning lamp
- **LAMP-IN** Inspection lamp
- **BULBKIT** Bulb and fuse kit
- **WRITEPAD** Writing pad
- **UPHTRI10** Seats: Black embossed textile insert with light grey sides, black vinyl side bolster with blue vinyl side insert.
Interior trim: Raven black bunk and curtains & blue textile side walls
- **UPHTRI11** Seats: Light grey embossed textile insert, black raven metallic vinyl bolster with red vinyl side insert.
Interior trim: Raven black bunk and curtains & grey vinyl side walls
- **UPHTRI12** Seats: Blue soft textile insert, black vinyl bolster.
Interior trim: Raven black bunk and curtains & blue textile side walls
- **UPHTRI13** Seats: Dark grey leather insert and black leather bolster.
Interior trim: Raven black bunk and curtains & grey vinyl side walls
- **UPHTRI14** Seat: Dark grey leather insert and black leather bolster.
Interior trim: Raven black bunk and curtains & blue textile side walls
- **DST-CF4** Driver seat, comfort, suspended, belt in seat
- **DST-CF5** Driver seat, comfort, suspended, belt in seat, electrically heated
- **DST-CF6** Driver seat, comfort, suspended, belt in seat, electrically heated, ventilated
- **SBD-RED** Red seat belts
- **SBPRE-DS** Driver seat belt pretensioner
- **PST-BAS1** Passenger seat - Fixed non suspended fold up with seatbelt mounted in cab
- **PST-BENC** Bench passenger seat
- **PST-CF4** Passenger seat - Comfort suspended with seatbelt mounted in seat
- **PST-CF5** Passenger seat - Comfort suspended & heated with seatbelt mounted in seat
- **PST-STD2** Passenger seat - Fixed non suspended with seatbelt mounted in cab
- **PST-STD4** Passenger seat - Standard suspended with seatbelt mounted in cab
- **SBPRE-PS** Passenger seat belt pretensioner
- **ARM-DBPS** Two armrests on driver seat and one (outer) on passenger seat
- **ARMRE-BB** Two armrests on both driver and passenger seat.
- **ARMRE-DB** Two armrests, on driver seat only
- **ARMRE-PB** Two armrests, on passenger seat only
- **ARMRE-PS** Single armrest (next to driver) on passenger seat
- **ARU-BAS** Vinyl upholstered armrest
- **ARU-LEA** Leather upholstered armrest
- **FMAT-RUB** Rubber floor mats
- **FMAT-TX2** Textile and rubber floor mats
- **LBK-RES** Foldable rest bunk
- **LBK70** Lower bunk 700 x2000 mm, fixed
- **ULBK** Without lower bunk
- **MATL-FI** Firm lower bunk pocket sprung mattress
- **MATL-SF** Lower flexizone mattress - semi-firm, pocket springs up to 100kg - 16 stone
- **MATL-SO** Lower flexizone mattress - soft, pocket springs up to 85kg - 13.5 stone

■ Standard Equipment

□ Optional Equipment

For more detailed information about cab and powertrain equipment, please refer to separate specification sheets.

For all possible options and combinations of options please consult your Volvo sales contact who can create a specification to match your requirements using the Volvo Sales Support system (VSS).

The factory reserves the right to modify design and change equipment without previous notification. The specification can vary from country to country.

MODEL RANGE

FM 13 6x4 Rigid - High T Ride - N3 Cranked front axle for on road work FM 64 R3HT

- | | | | |
|-----------------------------------------------------|-------------------------------------------------------------------------------------------------------------------------------------------|-----------------------------------------------------|-------------------------------------------------------------------------------------------------------------------------------------------------------------------------------------------------|
| <input type="checkbox"/> OLMAT-BA | 35mm mattress overlay protector | <input type="checkbox"/> BUMP-B | Plastic front bumper |
| <input type="checkbox"/> OLMAT-PR | 50mm premium mattress overlay protector | <input checked="" type="checkbox"/> BUMP-B2 | Steel front bumper |
| <input type="checkbox"/> TBK60F | Fixed foldable top bunk 600 x 1900mm | <input type="checkbox"/> BUMP-SP | Front bumper spoiler |
| <input type="checkbox"/> TBK70F | Fixed foldable top bunk 700 x 1900mm | <input type="checkbox"/> GUARD-EH | Engine guard to protect sump and engine hoses |
| <input type="checkbox"/> PH-CAB2 | 1.8kW Air to air night heater | <input checked="" type="checkbox"/> BUGNET | Insect screen in front of radiator |
| <input type="checkbox"/> PH-ENGCA | Engine and cab night heater | <input type="checkbox"/> CTILTP-E | Electrically operated hydraulic cab tilt |
| <input type="checkbox"/> PH-SS | Short stop heater | <input checked="" type="checkbox"/> CTILTP-M | Manually operated hydraulic cab tilt |
| <input type="checkbox"/> SLCP-BAS | Basic sleeper control panel - includes interior light, parking heater, roof hatch and door lock | <input type="checkbox"/> FCABS-A | Front cab suspension - Air |
| <input type="checkbox"/> SAFE | Safe box for driver's personal items | <input checked="" type="checkbox"/> FCABS-M | Front cab suspension - Mechanical spring |
| <input type="checkbox"/> ETSB-F | Storage on engine tunnel - on front top | <input type="checkbox"/> RCABS-A | Rear cab suspension - Air |
| <input type="checkbox"/> ETSB-FR | Storage on engine tunnel - on front top and at rear cab wall | <input checked="" type="checkbox"/> RCABS-M | Rear cab suspension - Mechanical spring |
| <input type="checkbox"/> ETSB-FRS | Storage on engine tunnel - on front top & at rear cab wall & storage recessed into tunnel on right hand side | <input type="checkbox"/> MIRCOMF2 | Electrically heated and operated FMX style main and wide-angle mirror on both sides, with manual passenger kerb mirror. To increase direct vision to the side the main mirrors have no cowlings |
| <input type="checkbox"/> ETSB-FS | Storage on engine tunnel - on front top and storage recessed into tunnel on right hand side | <input type="checkbox"/> MIRCOMFM | Electrically heated and operated main with manual wide-angle mirror - both sides - and passenger kerb mirror |
| <input type="checkbox"/> ETSB-R | Storage on engine tunnel - box at rear cab wall | <input type="checkbox"/> MIRSTD2 | Electrically heated - FMX - main with wide angle mirror on both sides and kerb view mirror on passenger side, to increase direct vision to the side the main mirrors have no cowlings |
| <input type="checkbox"/> ETSB-RS | Storage on engine tunnel - at rear cab wall and storage recessed into tunnel on right hand side | <input checked="" type="checkbox"/> MIRSTDFM | Electrically heated main mirror with wide angle mirror on both sides and kerb view mirror on passenger side |
| <input type="checkbox"/> ETSB-S | Storage on engine tunnel - recessed into tunnel on right hand side | <input checked="" type="checkbox"/> AMIR-F20 | Auxiliary front view mirror with a 200mm radius |
| <input type="checkbox"/> RUS-BAS | Rear cab upper storage 154 litres - 300 mm high | <input type="checkbox"/> SUNV-H | External smoke grey sunvisor |
| <input type="checkbox"/> RUS-HIG | Rear cab upper storage 245 litres - 440 mm high | <input type="checkbox"/> AD-ROOF | Roof air deflector |
| <input type="checkbox"/> TABLE | Folding and height adjustable table - on lower bunk | <input type="checkbox"/> AD-SIDEL | Side air deflector extension panels |
| <input type="checkbox"/> REF-ICPK | Fridge: engine tunnel mounted preparation kit | <input type="checkbox"/> AD-SIDES | Short cab side air deflector for rigid bodywork |
| <input type="checkbox"/> REFR-RUS | Fridge: 28 litre rear upper wall mounted with dividers | <input checked="" type="checkbox"/> HL-BASIC | Halogen H7 head lamps |
| <input type="checkbox"/> MICRO-PK | Preparation kit for microwave oven (wiring) | <input type="checkbox"/> HL-CLEAN | Head lamp cleaner - washer jets |
| <input type="checkbox"/> BOTH-D | One bottle holder under dashboard centre section | <input type="checkbox"/> HLP-ST | Headlamp protection |
| <input type="checkbox"/> COFMA-PK | Coffee maker, preparation kit. | <input checked="" type="checkbox"/> HL-ADJ | Headlight adjustment - Switch in cab |
| <input checked="" type="checkbox"/> INLI-BAS | Interior white LED lights - basic | <input type="checkbox"/> DRIVL2 | Two spot lamps |
| <input type="checkbox"/> INLI-NL | Interior white and red night LED light with no dimmer | <input checked="" type="checkbox"/> UDRIVL | Without auxiliary driving lights |
| <input type="checkbox"/> INLI-NLD | Interior white and red night LED light with dimmer | <input checked="" type="checkbox"/> FOGL-WC | Front fog lights |
| <input type="checkbox"/> ARL-FLEX | Two flexible reading lamps (snake lamps) | <input type="checkbox"/> CL-STAT | Static corner lights |
| <input type="checkbox"/> RH-ECS | Glass roof & escape hatch - Electrically operated | <input type="checkbox"/> ASL-RF2 | Two Hella H11 70W spotlamps in sign box - only available with the basic headlight and no lower driving lights. Preparation kit for two spotlamps in sign box |
| <input type="checkbox"/> RH-EE | Without roof hatch - Tinted glass emergency exit ONLY | <input type="checkbox"/> ASL-RFPK | Preparation kit for two spotlamps in sign box |
| <input type="checkbox"/> RH-ETR | Glass roof & escape hatch - Electrically operated, tinted glass with rear opening | <input type="checkbox"/> BEACOA2F | Two front roof mounted amber beacon rotating warning lamps |
| <input type="checkbox"/> RH-MSR | Steel roof & escape hatch - Manually operated with rear opening | <input type="checkbox"/> BEACOA2R | Two rear roof mounted (on accessory bracket) amber beacon flashing warning LED lamps |
| <input type="checkbox"/> RH-MTR | Glass roof & escape hatch - Manually operated, tinted glass with rear opening | <input type="checkbox"/> BEACON-P | Roof beacon wire preparation |
| <input checked="" type="checkbox"/> URH | Without roof hatch | <input type="checkbox"/> BEACONA4 | Four roof mounted (2 front/2 rear) amber beacon rotating warning lamps |
| <input type="checkbox"/> SWIND-BS | Extra side window on both sides behind "B" pillar | <input type="checkbox"/> CABPT-R1 | Single outlet for roof mounted accessories |
| <input type="checkbox"/> SWIND-PS | Rear side window, passenger side | <input checked="" type="checkbox"/> CABPT-R2 | Twin outlets for roof mounted accessories. |
| <input type="checkbox"/> VANMIR | Vanity mirror in front shelf | <input type="checkbox"/> SPOTP-F | Spotlamp preparation in front, max 280W |
| <input type="checkbox"/> AS-FUS | Extra shelf in front upper storage compartments | <input type="checkbox"/> SPOTP-R | Spotlamp preparation on roof, max 280W |
| <input type="checkbox"/> INFOT-PK | Preparation kit for the mounting of a flat screen TV in cab above the driver's door, includes bracket, electrical and speaker connections | <input type="checkbox"/> SPOTP-RF | Spotlamp preparation on cab roof and in cab front, max 2x280W |

CAB EXTERIOR

- | | |
|-----------------------------------------------------|------------------------------------------------------------------------------------------|
| <input type="checkbox"/> PAICS-B | Basic cab paint - mirrors, sunvisor, instep and bumper supplied in natural finish - grey |
| <input type="checkbox"/> PAICS-C | Complete cab - mirrors, insteps, sunvisor, and bumper finished in cab colour |
| <input checked="" type="checkbox"/> GLAS-TIN | Tinted windows. |
| <input type="checkbox"/> AWIND-RF | Rear window |
| <input type="checkbox"/> DGLAS-L | Laminated door glass |
| <input checked="" type="checkbox"/> LOCK-MAN | Manual door locking |
| <input type="checkbox"/> LOCK-MRP | Manual door locking with internal remote control (from driver side) of passenger door |
| <input type="checkbox"/> LOCK-REM | Central locking with remote control |

Standard Equipment

Optional Equipment

For more detailed information about cab and powertrain equipment, please refer to separate specification sheets.

For all possible options and combinations of options please consult your Volvo sales contact who can create a specification to match your requirements using the Volvo Sales Support system (VSS).

The factory reserves the right to modify design and change equipment without previous notification. The specification can vary from country to country.

MODEL RANGE

FM 13 6x4 Rigid - High T Ride - N3 Cranked front axle for on road work FM 64 R3HT

- ACCBB-FR** Front & rear roof mounted accessory brackets
- ACCBB-M** Middle roof mounted accessory bracket
- ACCBB-R** Rear roof mounted accessory bracket
- ACCBB-RM** Rear & middle roof mounted accessory brackets
- REFS-TW** White cab conspicuity markings by packed in cab
- REFS-TY** Yellow cab conspicuity markings by packed in cab

SUPERSTRUCTURE PREPARATIONS

- BP-MI02**
- BP-TI03**
- SRWL-PK** Wiring preparation for side & rear work/reverse lamps on side of chassis and a three-position switch, maximum 280W
- SWL-2FW** Two H3 70W white front chassis mounted (LH/RH side) working lamps and a 2-position switch (On/Off)
- SWL-2RW** Two H3 70W white rear chassis mounted (LH/RH side) working lamps and a 2-position switch (On/Off)
- SWL-4W** 4 H3 70W white front (2) & rear (2) chassis mtd (LH/RH side) working lamps & 2-pos switch (On/Off)
- SWL-PK** Wiring preparation for side work/reverse lamps on side of chassis and a three-position switch, maximum 280W
- WLC-H2A** Two H3/70W working lamps with amber coloured lens high mounted back of cab
- WLC-H2W** Two H3/70W white working lamps high mounted on the back of cab
- WLC-PKCH** Preparation kit (cables and switch) for cab mounted chassis working lamp
- WLC-PKH** Preparation kit, cables and switch for high mounted working lamps back of cab
- WLC-PKL** Preparation kit, cables and switch for low mounted working lamps back of cab
- WLC-PKLH** Preparation kit - cables and switch for low and high mounted working lamps back of cab.
- ECBB-BAS** Body builder electrical centre without body builder module
- ECBB-HIG** Body builder electrical centre with body builder module
- BBCHAS1** One 7-pole connector for Body builder interface
- BBCHAS3** Three 7-pole connectors for Body builder interface
- BEPR-T2** Body builder electrical software preparation for tipper with remote control
- EXSTER** External steering control, with VDS and bodybuilder module
- TD-BAS** Trailer detection WITHOUT LED sensing
- TD-LED** Trailer detection with LED sensing
- FRFS-BS** Frame rail free space on both sides to give space for crane legs or other equipment.
- FBA-BTF** Lower front body attachments for torsionally flexible - platform body
- FBA-BTSF** Lower front body attachments for torsionally semi-flexible body - box or curtainsider
- HBA-FSFB** Holes for body attachments - flexible/semi-flexible body
- HBA-SB** Holes for body attachments - stiff body
- RBA-T2** Lower rear body attachments for helper frame
- CRANEPK1** Crane plates mounted to frame, for cranes up to 10 tonne metre capacity
- CRANEPK2** Crane plates mounted to frame, for cranes up to 20 tonne metre capacity
- CRANEPK4** Crane plates mounted to frame, for cranes up to 40 tonne metre capacity
- AUXL-SPK** Electrical preparation kit - wiring and switch for snow plough lights
- TAILPRE2** Tail lift preparation kit, wireless remote operation
- TAILPREP** Taillift preparation kit - cab switch and warning in driver display
- AESW2** Two Body builder bistable electrical switches (marked AUX1 / AUX2)
- AESW2PK** 2 Body builder bistable el.switches (marked AUX1/AUX2) and prep. for 4 more switches
- AUXSW-4** Wiring for 4 extra switches (from Body builder electrical centre

to switch positions)

DELIVERY SERVICES

- TGW-4GWL** GSM/GPRS/4G modem, LTE & WLAN for telematics gateway
- FMS-PK** Fleet Management System gateway

Volvo Truck Corporation

volvotrucks.com