

# MODEL RANGE

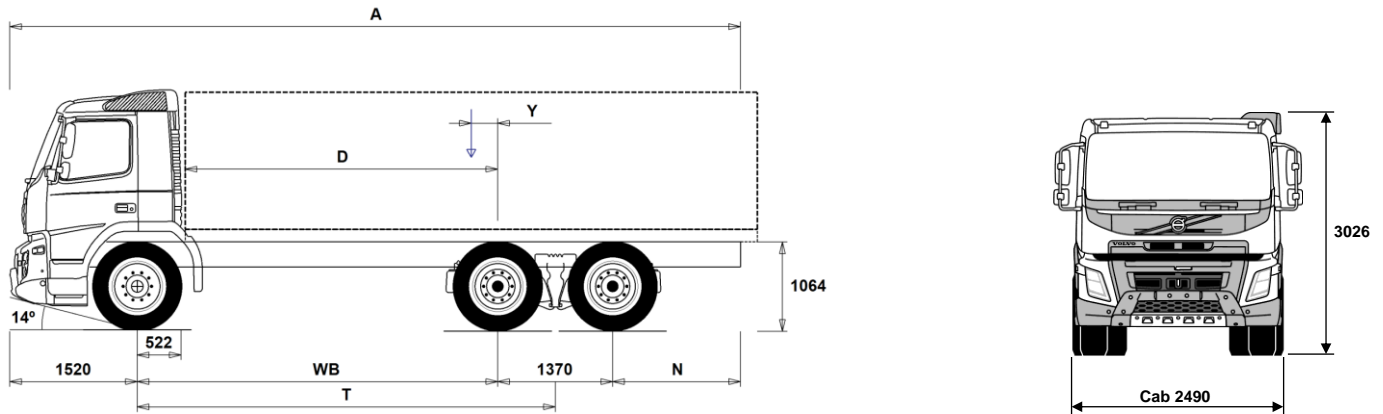

Volvo Trucks. Driving Progress

FMX13 6x4 Rigid - Rear Air Suspension - N3 Cranked front axle for on road work FM 64



## Chassis Dimensions [mm]

WB Wheelbase	3400	3700	3900	4300	4600	4900	5200	5600
A Overall Chassis Length	8165	8615	8915	9565	10015	10465	10965	11565
D Center of rear axle to front of body	2828	3128	3328	3728	4028	4328	4628	5028
N Rear Overhang (Min.)	1225	1225	1225	1225	1225	1225	1225	1225
N Rear Overhang (Max.)	1875	2025	2125	2375	2525	2675	2875	3075
T Theoretical Wheelbase	4085	4385	4585	4985	5285	5585	5885	6285
Y Center of Gravity for Payload (Min.)	-119	-80	-54	-1	38	75	115	164
Y Center of Gravity for Payload (Max.)	106	163	201	276	332	387	445	518

## Chassis Weights [kg]

Front Axle	4490	4505	4515	4535	4545	4570	4575	4595
Rear Bogie	3415	3435	3450	3495	3520	3565	3595	3630
Kerb Weight	7905	7940	7965	8030	8065	8135	8170	8225
Payload (including body, driver, fuel, etc.)	18095	18060	18035	17970	17935	17865	17830	17775

## Turning Diameter [mm]

Turning Circle Diameter Kerb to Kerb	14500	15500	16100	17300	18200	19100	20000	21300
Turning Circle Diameter Wall to Wall	16000	16900	17500	18800	19700	20600	21500	22800

## Plated Weights [kg]

	Plated	Design
Gross Vehicle Weight	26000	29000
Gross Combination Weight	44000	44000
Front Axle	8000	8000
Rear Bogie	19000	21000

## Important Notes

### Chassis Dimensions

Cab Height: +416 mm for CAB-HSLP, +554 mm for CAB-XHSL.  
Front Axle to Back of Cab: +424 mm for CAB-HSLP and CAB-SLP and CAB-XHSL.

D-measure includes a front clearance of 50 mm and for rigid trucks also a subframe of 100 mm.

Height can vary  $\pm 20$  mm for leaf and  $\pm 10$  mm for air suspension.

All dimensions are for unladen chassis and any tag axles down. Chassis height used: CHH-HIGH.

Rear overhang used for vehicle weight calculation is the maximum rear overhang (N Max.) for selected wheelbase.

Height change when chassis height CHH-MED, FRAME300: 0 mm.

Weight and dimensions are based upon the following tyres:

Front Axle Tyres: 315/80R22.5  
Drive Axle Tyres: 315/80R22.5

**Chassis weight includes oil, water, AdBlue, 0 litres fuel and without driver. Kerb weight can vary  $\pm 3\%$ .**

Turning diameters are theoretically calculated.

Legal weights can differ from country to country.

For more detailed weight information, including optional equipment weights, ask your Volvo sales contact to enter your specification into the Volvo Weight Information system (WIS).

Do NOT use this drawing for bodybuilding. Refer to Volvo Bodybuilder Instructions and chassis assembly drawing FM64R3HAX.

# MODEL RANGE

FMX13 6x4 Rigid - Rear Air Suspension - N3 Cranked front axle for on road work FM 64

## TRUCK USE

- PTO-HT16** High torque power take-off up to 1600Nm
- PTO-HT20** High torque power take-off up to 2000Nm
- RC-ROUGH** Operating class on/off road
- RC-SMOOT** Operating class highway
- GARB-PRE** Garbage preparation
- SWAPBODY** Swap body vehicle preparation
- TIPP-PRE** Tipper vehicle preparation
- UNIFORM** Basic platform vehicle

## CORE COMPONENTS

- CHH-HIGH** Chassis height high - N3 "On Road" chassis - For a specific loading height always check the unique BEP chassis drawing
- CHH-MED** Chassis height medium - For a specific loading height always check the unique BEP chassis drawing
- RADD-GR** RADD-GR - 6x4/8x4 Air - High
- FMX-DAY** Day cab - with steel safety cage design  
Designed and built to Swedish impact and ECE R29 regulations
- FMX-HSLP** Globetrotter cab - with steel safety cage design  
Designed and built to Swedish impact and ECE R29 regulations
- FMX-SLP** Sleeper cab - with steel safety cage design  
Designed and built to Swedish impact and ECE R29 regulations
- EU6SCR** Emission level - Euro 6
- D13 420S** D13K420 12.8 litre engine developing 420hp at 14-1800rpm.  
Peak torque 2100Nm at 860 -1400rpm.
- D13 460S** D13K460 12.8 litre engine developing 460hp at 14-1800rpm.  
Peak torque 2300Nm at 900-1400rpm.
- D13 500S** D13K500 12.8l engine developing 500hp at 14-1800rpm.  
Peak torque 2500Nm at 1000-1400rpm.
- D13 540S** D13K540 12.8l engine developing 540hp at 14-1800rpm.  
Peak torque 2600Nm at 1000-1450rpm.
- D13K420** D13K420 - 420hp engine
- D13K460** D13K460 - 460hp engine
- D13K500** D13K500 - 500hp engine
- D13K540** D13K540 - 540hp engine
- EBR-EPG** Exhaust brake controlled by steering column switch
- EBR-EPGC** Exhaust pressure governor for I shift gearbox
- EBR-VEB+** Volvo engine brake + and exhaust pressure governor, enhanced performance from additional exhaust rocker control. Retardation 375kW
- AT2612F** AT2612F 12-speed "I-shift" automated mechanical gearbox suitable for gross train weights up to 60tonne only refer to sales engineering when used in conjunction with a PTO
- ATO2612F** ATO2612F 12-speed "I-shift" overdrive automated mechanical gearbox suitable for gross train weights up to 60tonne refer to sales engineering when used in conjunction with a PTO
- PT2606** Powertronic automatic 6-speed gearbox, max. engine torque 2600 Nm, max. permitted GCW 130000 kg
- SPO2812** SPO2812 - 12 speed I-shift Dual Clutch automated mechanical gearbox GCW 60tonne
- TAAXLIFT** Rear axle lift for double drive bogie  
CONTACT VOLVO SALES ENGINEERING to check lift capability
- RTH2610F** RTH2610F hub reduction tandem 26tonne drive axles, GCW 100 tonnes with differential and cross locks\*  
\* Cross locks replaced by a dog clutch if tandem axle lift is specified
- RTS2310A** RTS2310A single reduction tandem 23tonne drive axles with differential and cross locks\* - design GCW 100tonnes.  
\* Cross locks replaced by a dog clutch if tandem axle lift is specified.
- RTS2370A** RTS2370A single reduction tandem 23tonne drive axles with differential and cross locks\* - design GCW 70tonnes.

Standard Equipment

Optional Equipment

For more detailed information about cab and powertrain equipment, please refer to separate specification sheets.

For all possible options and combinations of options please consult your Volvo sales contact who can create a specification to match your requirements using the Volvo Sales Support system (VSS).

The factory reserves the right to modify design and change equipment without previous notification. The specification can vary from country to country.

\* Cross locks replaced by a dog clutch if tandem axle lift is specified.

## PACKAGES

- DRIVEFM** Cab Package: Drive
- DRIVEFM+** Cab Package: Drive +
- BEDFM** One bed resting package
- AUDHIG** High Power Audio system: RDS radio with CD player - also playing MP3/WMA files from CD -, with integrated bluetooth phone and USB/Line inputs. FM/AM antenna, speakers in dashboard, doors, and sleeping compartment.
- MEDIA** AM/FM Bluetooth radio without CD player.  
USB and Aux line inputs.  
Speakers in dashboard, doors, and sleeping compartment.  
7" touch screen with personal apps.
- MEDIADF** AM/FM Bluetooth radio without CD player.  
USB and Aux line inputs.  
Speakers in dashboard, doors, and sleeping compartment.  
7" touch screen with personal and professional apps.  
Dynafleet vehicle on-board data display with office internet support.
- MEDIANAV** AM/FM Bluetooth radio without CD player.  
USB and Aux line inputs.  
Speakers in dashboard, doors, and sleeping compartment.  
7" touch screen with personal and professional apps.  
Truck based satellite navigation (live updates not included)
- MEDIANDF** AM/FM Bluetooth radio without CD player.  
USB and Aux line inputs.  
Speakers in dashboard, doors, and sleeping compartment.  
7" touch screen with personal and professional apps.  
Truck based satellite navigation (live updates not included)  
Dynafleet vehicle on-board data display with office internet support.
- VISIX15** Visibility Package
- ASAF15** Active Safety Package
- RCHAPAC1** Chassis Package Rigid

## CHASSIS

- FST-AIR** Front suspension type - air
- FST-PAR** Front suspension type - 2 leaf parabolic springs
- FST-PAR3** Front suspension type - 3 leaf parabolic springs
- FSL5-BAS** Front suspension levelling - basic stroke
- FSL5-HI** Front suspension levelling - high stroke for demount operations - check with bodybuilder
- FAL10.0** Front axle design capacity 10 tonnes - Ensure that you have checked the tyre load index
- FAL7.1** Front axle design capacity 7.1 tonnes
- FAL7.5** Front axle design capacity 7.5 tonnes
- FAL8.0** Front axle design capacity 8.0 tonnes - Ensure that you have checked the tyre load index
- FAL8.5** Front axle design capacity 8.5 tonnes
- FAL9.0** Front axle design capacity 9.0 tonnes - Ensure that you have checked the tyre load index
- FSM-LUB** Lubricated rear shackles on front suspension pins and bushings
- FSTAB** Front anti-roll bar
- FSTAB2** Front anti-roll bar medium stiffness
- FSTAB3** Front stiff anti-roll bar
- RAL21** Rear bogie design capacity 21 tonnes
- RAL23** Rear bogie design capacity 23 tonnes
- RAL26** Rear bogie design capacity 26 tonnes
- RSTAB1** Rear anti-roll bar
- RSTAB3** Rear stiff anti-roll bar
- RALIM105** Rear axle load limiter, 10.5 tonnes
- RALIM115** Rear axle load limiter, 11.5 tonnes
- RALIM13** Rear axle load limiter, 13 tonnes
- RALIM95** Rear axle load limiter, 9.5 tonnes
- ASF-DL1** Air suspension with 1 driving level

# MODEL RANGE

## FMX13 6x4 Rigid - Rear Air Suspension - N3 Cranked front axle for on road work FM 64

- |   |  |
|---|--|
| <ul style="list-style-type: none"> <li><input type="checkbox"/> <b>ACTST-TO</b> Volvo Dynamic Steering (VDS) with with extra electronic pump and torque overlay</li> <li><input type="checkbox"/> <b>ASFE-BAS</b> Active steering feature - Basic - Volvo Dynamic Steering only</li> <li><input type="checkbox"/> <b>ASFE-PS</b> Active steering feature - Volvo Dynamic Steering with personal settings</li> <li>■ <b>PSS-SING</b> Single power steering system</li> <li>■ <b>PSP-FIX</b> Power steering pump with fixed displacement</li> <li><input type="checkbox"/> <b>PSP-VAR</b> Power steering pump with variable displacement</li> <li>■ <b>EBS-MED</b> EBS medium package including "hill" hold function</li> <li><input type="checkbox"/> <b>AUXPARK</b> Additional spring parking brakes</li> <li>■ <b>FBREG-E</b> Front regulating brake valve, EBS</li> <li>■ <b>SUSPL-EC</b> Remote electronic control on wander-lead for air suspension levelling</li> <li><input type="checkbox"/> <b>FRAME266</b> Frame rail section external height 266 mm</li> <li>■ <b>FRAME300</b> Frame rail section external height 300 mm</li> <li><input type="checkbox"/> <b>FST7070</b> Frame thickness - web and flange 7.0mm</li> <li>■ <b>FST8080</b> Frame thickness - web and flange 8.0mm</li> <li><input type="checkbox"/> <b>FIL-EEEB</b> Inner liner from end of engine to end of bogie</li> <li><input type="checkbox"/> <b>FIL-EEEF</b> Inner liner from end of engine to end of frame</li> <li><input type="checkbox"/> <b>FIL-FBEB</b> Inner liner over rear bogie</li> <li><input type="checkbox"/> <b>FIL-FBEF</b> Inner liner from front of bogie to end of frame</li> <li><input type="checkbox"/> <b>FIL-TXEB</b> Inner liner from gearbox member to end of bogie</li> <li><input type="checkbox"/> <b>FIL-TXEF</b> Inner liner from gearbox member to end of frame</li> <li>■ <b>BBOX-L</b> Battery box located on left hand side</li> <li><input type="checkbox"/> <b>BATS-D</b> Dual energy battery system - 2 living batteries and 2 starter batteries.</li> <li>■ <b>BATS-S</b> Single energy battery system (2 batteries)</li> <li><input type="checkbox"/> <b>2BAT210B</b> 2 x 210 Ah capacity Gel batteries</li> <li>■ <b>2BATT170</b> 2 x 170 Ah capacity batteries</li> <li><input type="checkbox"/> <b>2BATT225</b> 2 x 225 Ah capacity batteries</li> <li>■ <b>BATTAMP</b> Battery voltage and ampere gauge</li> <li><input type="checkbox"/> <b>BATTIND</b> Battery charge indication</li> <li><input type="checkbox"/> <b>ADR2</b> ADR package for transportation of dangerous goods on road (Note does NOT include safe loading pass package if required this is quoted separately)</li> <li><input type="checkbox"/> <b>MSWI-A</b> Main switch - ADR switch circuit shut down</li> <li>■ <b>MSWI-C</b> Main switch - Chassis mounted toggle switch by battery box</li> <li><input type="checkbox"/> <b>MSWI-R</b> Main switch - Key fob operated remote controlled</li> <li>■ <b>R365A71</b> Right tank 365litre aluminium diameter 710mm<br/>Min volume 255l<br/>Max volume 885l</li> <li>■ <b>UL-FUEL</b> Without left fuel tank<br/>Min volume 160l<br/>Max volume 730l</li> <li><input type="checkbox"/> <b>ADTP-L</b> AdBlue tank on left hand side</li> <li>■ <b>ADTP-R</b> AdBlue tank on right hand side</li> <li><input type="checkbox"/> <b>ADB048</b> AdBlue tank usable volume 48 litres</li> <li>■ <b>ADB064</b> AdBlue tank usable volume 64 litres</li> <li><input type="checkbox"/> <b>ADB068</b> AdBlue tank usable volume 68 litres</li> <li><input type="checkbox"/> <b>ADB090</b> AdBlue tank usable volume 90 litres</li> <li><input type="checkbox"/> <b>ADB100</b> AdBlue tank usable volume 100 litres</li> <li><input type="checkbox"/> <b>ADTC-BF</b> AdBlue tank cover with satin alloy look decorative cover</li> <li>■ <b>FCAP-L</b> Locking fuel filler cap</li> <li>■ <b>FUFF-AS</b> Fuel filling anti-spillage device</li> <li><input type="checkbox"/> <b>FUFF-ATS</b> Fuel filling anti-theft and anti-spillage devices</li> <li><input type="checkbox"/> <b>ESH-LEFT</b> Horizontal silencer, left exhaust outlet</li> <li>■ <b>ESH-REAR</b> Horizontal silencer, rear exhaust outlet</li> <li><input type="checkbox"/> <b>ESH-RIGH</b> Horizontal silencer, right exhaust outlet</li> <li><input type="checkbox"/> <b>ESH-VERT</b> Horizontal silencer, vertical exhaust outlet</li> <li><input type="checkbox"/> <b>EXST-SSP</b> Stainless steel exhaust stack - NOT polished</li> </ul> | <ul style="list-style-type: none"> <li><input type="checkbox"/> <b>EXST-ST</b> Steel exhaust stack</li> <li><input type="checkbox"/> <b>HS-NAR</b> Narrow heat shield</li> <li><input type="checkbox"/> <b>WHC-FIX2</b> Two fixed wheel chocks</li> <li><input type="checkbox"/> <b>WHC-FOL2</b> Two foldable wheel chocks</li> <li><input type="checkbox"/> <b>WHCP-F</b> Wheel chock(s) stored in the front part of the vehicle</li> <li><input type="checkbox"/> <b>WHCP-M</b> Wheel chock(s) stored in the middle part of the vehicle</li> <li><input type="checkbox"/> <b>WHCP-R</b> Wheel chock(s) stored in the rear part of the vehicle</li> <li><input type="checkbox"/> <b>WHCP-T</b> Transport mounted wheel chock(s) stored in cab outer luggage locker</li> <li><input type="checkbox"/> <b>TB-L80</b> Toolbox 800 mm, left side</li> <li><input type="checkbox"/> <b>TB-R80</b> Toolbox 800 mm, right side</li> <li><input type="checkbox"/> <b>SUP-BAS</b> EC approved chassis side guards</li> <li><input type="checkbox"/> <b>SUP-LOW</b> EC approved low chassis side guards</li> <li><input type="checkbox"/> <b>CHAIN-S</b> Snow chains</li> <li><input type="checkbox"/> <b>HOOK-SC</b> Snow chain hooks</li> <li>■ <b>TOWF-HD1</b> One heavy duty front towing device</li> <li><input type="checkbox"/> <b>TOWMBRH</b> Towing member, high mounted in centre of frame, D = 190</li> <li><input type="checkbox"/> <b>TOWMBRL1</b> Towing member, low mounted under the frame</li> <li><input type="checkbox"/> <b>TOWMBRL2</b> Towing member, low and forward mounted under the frame</li> <li><input type="checkbox"/> <b>TOWMBRL3</b> Towing member, low and far forward mounted under the frame</li> <li><input type="checkbox"/> <b>TOWMBRM</b> Towing member, medium mounted in line with frame lower flange</li> <li><input type="checkbox"/> <b>RFEC-L</b> Rear frame end, lower flange cut for centre axle drawbar.</li> <li>■ <b>RFEC-S</b> Rear frame end, straight cut for regular platform applications</li> <li><input type="checkbox"/> <b>RFEC-U</b> Rear frame end, upper cut for tipper applications.</li> <li><input type="checkbox"/> <b>C-RI4040</b> Towing coupling, Ringfeder 4040 G-150</li> <li><input type="checkbox"/> <b>C-RI5055</b> Towing coupling, Ringfeder 5055 G-150</li> <li><input type="checkbox"/> <b>C-RO400G</b> Towing coupling, Rockinger 400 G-150 for 40mm eyes</li> <li><input type="checkbox"/> <b>C-RO50</b> Rockinger RO 50 50mm for centre axle trailer</li> <li><input type="checkbox"/> <b>TOWR-ONE</b> Towing hitch attached to rear crossmember</li> <li>■ <b>TREL-PK</b> Trailer electrical preparation kit - chassis/cab wiring</li> <li><input type="checkbox"/> <b>TREL14</b> Single 14 pole electrical trailer connector</li> <li><input type="checkbox"/> <b>TREL15</b> Single 15 pole electrical trailer connector - ADR certified</li> <li><input type="checkbox"/> <b>TREL7</b> 7 pole - 24N trailer electrical suzie</li> <li><input type="checkbox"/> <b>TREL7-7</b> 24N and 24S trailer electrical suzies</li> <li><input type="checkbox"/> <b>TBC-DUO</b> Duomatic type air line connectors</li> <li><input type="checkbox"/> <b>TBC-EC</b> Palm coupling type air line connectors</li> <li><input type="checkbox"/> <b>TRBR-HCF</b> Full pressure hand controlled trailer brake</li> <li><input type="checkbox"/> <b>TRBR-STA</b> Stationary trailer brake control</li> <li><input type="checkbox"/> <b>TRB-STRE</b> Stretch Brake - Automatic low speed trailer brake activation to avoid jack-knifing and improve steerability</li> <li><input type="checkbox"/> <b>RUP-FOLD</b> Folding EC approved aluminium rear underrun</li> <li><input type="checkbox"/> <b>RUP-FOSL</b> Folding &amp; sliding EC approved aluminium rear underrun</li> <li><input type="checkbox"/> <b>RFEND-B</b> Three piece EC approved rear mud wings and spray flaps</li> <li><input type="checkbox"/> <b>RFEND-T</b> Rear mud wings, transport mounted</li> <li><input type="checkbox"/> <b>RFH-BAS</b> Basic rear wing height</li> <li><input type="checkbox"/> <b>RFH-HIG</b> High rear wing height - higher wing tops</li> <li><input type="checkbox"/> <b>RFH-LOW</b> Lower rear wing height - shallower wing tops</li> <li><input type="checkbox"/> <b>AUXATNK</b> Auxiliary airtank</li> <li><input type="checkbox"/> <b>ATANK-AL</b> Aluminium air tanks</li> <li>■ <b>ATANK-ST</b> Steel air tanks</li> <li><input type="checkbox"/> <b>RESTS-W</b> White conspicuity markings on chassis - sideguards, toolbox and rear overhang</li> <li><input type="checkbox"/> <b>REST-RUP</b></li> <li>■ <b>TL-LED</b> Rear lights LED</li> <li><input type="checkbox"/> <b>BLIGHT-E</b> Emergency brake light</li> </ul> |
|---|--|
- Standard Equipment      □ Optional Equipment

For more detailed information about cab and powertrain equipment, please refer to separate specification sheets.

For all possible options and combinations of options please consult your Volvo sales contact who can create a specification to match your requirements using the Volvo Sales Support system (VSS).

The factory reserves the right to modify design and change equipment without previous notification. The specification can vary from country to country.

# MODEL RANGE

## FMX13 6x4 Rigid - Rear Air Suspension - N3 Cranked front axle for on road work FM 64

- **RT-ALDP** Alcoa Dura-Bright EVO aluminium rims with standard holes long stud fixing on all axles, requires cleaning with a ph neutral solution - washing up liquid.
  - **RT-ALDPD** Alcoa Dura-Bright EVO aluminium rims with countersunk holes for short stud fixing on all axles, requires cleaning with a ph neutral solution - washing up liquid.
  - **RT-ALDU** Alcoa brushed aluminium rims with countersunk holes for short stud fixing on all axles
  - **RT-STEEL** Steel rims on all axles
  - **WCAP** Aerodynamic hub caps
  - **BRREC001** Bridgestone ECOPIA H - Energy rating C
  - **BRREC002** Bridgestone Ecopia H 002 Evo - Tyre recommendation 2
  - **COREC001** Continental ECOPLUS HS3 XL/HD3 - Energy rating B or C depending on size
  - **COREC002** Continental ECOPLUS HS3/HD3 - Energy rating B or C depending on size
  - **COREC003** Continental Efficient Pro S/D - Fuel Tyre Recommendation 3 Reduced mileage compared to Conti EcoPlus long haul pattern please consider when selecting these tyres.
  - **GYREC002** Goodyear FUELMAX S/D - Energy rating B or C depending on size
  - **GYREC003** Goodyear FUELMAX S/(O)/D - Fuel tyre Recommendation 3
  - **GYREC004** Goodyear FUELMAX S - Energy rating B depending on size
  - **HAREC001** Hankook AL10+ E-Cube Max Long Haul Tyre - Energy rating B
  - **HAREC002** Hankook AL10+ E-Cube Long Haul Tyre - Energy rating B with wide single
  - **MIREC001** Michelin XFA2/X-LINE Energy - Fuel tyre Recommendation 1
  - **MIREC002** Michelin XZA2/X-LINE Energy - Fuel tyre Recommendation 2
  - **MIREC003** Michelin X-LINE Energy - Fuel tyre Recommendation 3
  - **MIREC004** Michelin X Line Energy F/D2 - Energy rating A
  - **PIREC001** Pirelli FH:01 Proway - Long Haul Tyre - Energy rating B
  - **PIREC002** Pirelli FH:01 II Long Haul Tyre - Energy rating B with wide single
  - **SPWT-D** Spare wheel & tyre with rear tyre pattern
  - **SPWT-F** Spare wheel & tyre with front tyre pattern
  - **SWCP-LF** Spare wheel carrier on left side of chassis ahead of rear axle
  - **SWCP-R** Rear mounted spare wheel carrier
  - **SWCP-T** Spare wheel supplied temporarily strapped to chassis
  - **SWCP-TP** Temporary spare wheel carrier on top of chassis frame
  - **JACK-12T** 12 tonne bottle jack
  - **JACK-15T** 15 tonne bottle jack
  - **JACK-20T** 20 tonne bottle jack
  - **TOOL-BAS** Basic Toolkit
  - **TOOLKIT** Complete tool kit
  - **INFLAHOS** Tyre inflation hose
  - **GAUGE-TP** Tyre pressure gauge
- DRIVELINE EQUIPMENT**
- **ASO-C** Crawler gear -  
Ratio direct top gearbox 19:1  
Ratio Overdrive gearbox 17:1
  - **ASO-ULC** Ultra low crawler and crawler gear -  
Ratios direct top gearbox 32:1 and 19:1  
Ratios Overdrive box 32:1 and 17:1
  - **TRAP-HD** Reinforced gearbox application
  - **TP-CON** Construction Package
  - **TP-DIST** Distribution Package
  - **TP-HD** I-shift software - Heavy duty for high GCW  
Special conditions apply consult Sales Engineering
  - **TP-LONG** Long Haul Package
  - **AMSO-AUT** Enhanced I-shift software with manual shift available in auto mode and kickdown facility on accelerator pedal
  - **AVO-ENH** Enhanced software for off road driveability and starting
  - **APF-ENH** I-shift enhanced PTO functions
  - **RET-TH** Gearbox mounted retarder
  - **RET-TPT** Hydraulic Retarder for Powertronic gearbox
  - **TC-HWO** Automatic gearbox oil cooler - water to oil
  - **TC-MAOH2** Extra high performance transmission oil cooler - air to oil with front mounted radiator
  - **TC-MWO** Basic transmission oil cooler - water to oil
  - **2COM1100** Two cylinder, air compressor, 1100 litres per minute
  - **2COMP900** Two cylinder, air compressor, 900 litres per minute
  - **CLU-AIRC** Clutchable air compressor
  - **AIRIN-HI** Roof mounted air intake behind cab on left hand side
  - **AIRIN-LO** Low level air intake behind cab on left hand side
  - **ACL1ST-S** Two stage air filter
  - **24AL110B** 110 amp alternator
  - **24AL120B** 120 amp alternator
  - **24AL150B** 150 amp alternator
  - **CCV-C** Closed crankcase engine ventilation
  - **CCV-O** Open crankcase engine breather
  - **CCV-OX** Closed crankcase ventilation for cold markets
  - **PRIM-EL** Electrical priming pump
  - **PRIM-MAN** Manual priming pump
  - **FUEQ-EH** Fuel line electric heater
  - **AF-R** Hot fuel recirculation heated fuel filter
  - **FUEFE2LW** Large engine mounted dual fuel filter with water separator
  - **FUEFE2SW** Small engine mounted dual fuel filter with water separator
  - **EST-AID** Air inlet manifold starting heater element
  - **220EBH15** 220V/1.5Kw electric engine block heater
  - **PTER-100** Rear engine mounted power-take-off with DIN 100 / ISO 7646 flange
  - **PTER-DIN** Rear engine mounted PTO with DIN5462 (female) splined shaft for a close coupled pump.  
Models with 3 steering axles will use this to drive the steering pump (AUXPSP)
  - **PTER1400** Rear engine mounted power-take-off with SAE 1410 flange
  - **HPE-F101** Parker F1-101, engine mounted, fixed displacement, single flow, engine mounted hydraulic pump
  - **HPE-F41** Parker F1-41, engine mounted, fixed displacement, single flow, engine mounted hydraulic pump
  - **HPE-F51** Parker F1-51, engine mounted, fixed displacement, single flow, engine mounted hydraulic pump
  - **HPE-F61** Parker F1-61, engine mounted, fixed displacement, single flow, engine mounted hydraulic pump
  - **HPE-F81** Parker F1-81, engine mounted, fixed displacement, single flow, engine mounted hydraulic pump
  - **HPE-T53** Parker F2-53/53, engine mounted, Fixed displacement, Twin flow engine mounted hydraulic pump
  - **HPE-T70** Parker F2-70/35, engine mounted, Fixed displacement, Twin flow engine mounted hydraulic pump
  - **HPE-V45** Parker VP1-45, variable displacement, single flow, engine mounted hydraulic pump
  - **HPE-V75** Parker VP1-75, variable displacement, single flow, engine mounted hydraulic pump
  - **PTPT-D** Powertronic PTO, 1 front/upper DIN connection for plug-in pump (max. 850 Nm)
  - **PTPT-F** Powertronic PTO, 1 front/upper rear facing SAE flange conn. for prop shaft (max.850 Nm)
  - **PTR-D** Gearbox PTO for plug-in pump, 0.71xeng speed
  - **PTR-DH** Gearbox driven high speed PTO for one plug-in hydraulic pump
  - **PTR-DM** Gearbox driven medium speed PTO for one plug-in hydraulic pump
  - **PTR-F** Gearbox driven PTO with rear flange connection
  - **PTR-FH** Gearbox driven high speed PTO with SAE drive flange
  - **PTR-FL** Gearbox driven low speed PTO with SAE drive flange
  - **PTRD-D** Gearbox driven HIGH SPEED PTO for two plug-in hydraulic pumps
  - **PTRD-D1** PTRD-D1 Gearbox driven HIGH SPEED PTO (1 SAE flange & 1 plug-in hydraulic pump)
  - **PTRD-D2** Gearbox driven HIGH SPEED PTO (2 SAE flanges & 1 plug-in hyd pump)
  - **PTRD-F** PTO with 1 DIN + 1 flange connection rear, manual gearbox
- Standard Equipment      □ Optional Equipment

For more detailed information about cab and powertrain equipment, please refer to separate specification sheets.

For all possible options and combinations of options please consult your Volvo sales contact who can create a specification to match your requirements using the Volvo Sales Support system (VSS).

The factory reserves the right to modify design and change equipment without previous notification. The specification can vary from country to country.

# MODEL RANGE

## FMX13 6x4 Rigid - Rear Air Suspension - N3 Cranked front axle for on road work FM 64

- |  |  |
|--|--|
| <ul style="list-style-type: none"> <li><input type="checkbox"/> <b>HPG-F101</b> Parker F1-101 gearbox mounted, fixed displacement, single flow, hydraulic pump</li> <li><input type="checkbox"/> <b>HPG-F41</b> Parker F1-41 gearbox mounted, fixed displacement, single flow, hydraulic pump</li> <li><input type="checkbox"/> <b>HPG-F51</b> Parker F1-51 gearbox mounted, fixed displacement, single flow, hydraulic pump</li> <li><input type="checkbox"/> <b>HPG-F61</b> Parker F1-61 gearbox mounted, fixed displacement, single flow, hydraulic pump</li> <li><input type="checkbox"/> <b>HPG-F81</b> Parker F1-81 gearbox mounted, fixed displacement, single flow, hydraulic pump</li> <li><input type="checkbox"/> <b>EIDLESD</b> Engine idle shut down</li> <li><input checked="" type="checkbox"/> <b>STWPOS-R</b> RIGHT HAND DRIVE</li> <li><input type="checkbox"/> <b>STWM-LE</b> Leather steering wheel</li> <li><input type="checkbox"/> <b>STGW-AD2</b> Adjustable steering wheel with neck tilt</li> <li><input checked="" type="checkbox"/> <b>STGW-ADJ</b> Adjustable steering wheel</li> <li><input checked="" type="checkbox"/> <b>AIRBAG</b> SRS Driver's air bag</li> <li><input checked="" type="checkbox"/> <b>DRC-AMII</b> DPF Regeneration control switch - for manual and switching off regeneration</li> <li><input checked="" type="checkbox"/> <b>1DAYDIG2</b> Continental VDO DTCO 4.0 smart tachograph<br/>This tachograph can ONLY offer remote download if the option of Dynafleet or an FMS gateway has been specified with this order.</li> <li><input type="checkbox"/> <b>1DAYDIGP</b> Continental VDO DTCO 3.0 digital tachograph<br/>For vehicles with long lead time - this includes prep kit for the retrofit of DTCO 4.0 tachograph.<br/>For updating to new legal demand for trick registration from 15th June 2019.<br/>This tachograph can ONLY offer remote download if the option of Dynafleet or an FMS gateway has been specified with this order.</li> <li><input type="checkbox"/> <b>ARSL</b> Additional road speed limit - switch in dashboard</li> <li><input type="checkbox"/> <b>SPEED-DU</b> Dual speed limiter</li> <li><input type="checkbox"/> <b>CRUIS-E</b> Eco cruise control (with eco-roll and I-cruise, controls in steering wheel)</li> <li><input checked="" type="checkbox"/> <b>CRUISEC</b> Cruise control, standard</li> <li><input checked="" type="checkbox"/> <b>ESP-BAS1</b> Electronic Stability Control</li> <li><input type="checkbox"/> <b>ESPC-RO</b> ESP (Electronic Stability Program) functionality control - Reduced / Off</li> <li><input type="checkbox"/> <b>HWSS-ACB</b> Adaptive cruise control ACC with forward collision warning and AEBS advanced emergency brake system</li> <li><input checked="" type="checkbox"/> <b>HWSS-FCB</b> Forward collision warning with AEBS advanced emergency brake system</li> <li><input checked="" type="checkbox"/> <b>LSS-DW</b> Lane departure-warning system</li> <li><input type="checkbox"/> <b>LCS</b> Lane change support</li> <li><input type="checkbox"/> <b>DAS-W</b> Driver Alert Support system</li> <li><input type="checkbox"/> <b>RSSENS-W</b> Rain sensing windscreen wipers</li> <li><input type="checkbox"/> <b>CU-ECC</b> Electrically controlled air conditioning with sun sensor</li> <li><input type="checkbox"/> <b>CU-ECC2</b> Electrically controlled air conditioning with sun sensor, mist sensor, air quality sensor and carbon filter</li> <li><input checked="" type="checkbox"/> <b>CU-MCC</b> Climate unit with manual controlled air conditioning</li> <li><input checked="" type="checkbox"/> <b>IMMOBIL</b> Thatcham H2 approved immobiliser</li> <li><input type="checkbox"/> <b>ALARM-B</b> Thatcham H1 approved vehicle alarm - Cab only</li> <li><input type="checkbox"/> <b>ALARM-E</b> Enhanced vehicle alarm - Thatcham H1 approved - Cab plus external sensor for body/trailer</li> <li><input type="checkbox"/> <b>ALCOLOCK</b> Alcolock</li> <li><input type="checkbox"/> <b>BUPMON</b> Back up monitor with built in 7" screen on dash and one colour camera supplied loose for fitment by bodybuilder.<br/>Can accommodate up to 4 cameras for TfL Safe Scheme, CLOCS and FORS.</li> </ul> | <ul style="list-style-type: none"> <li><input type="checkbox"/> <b>PHONE-PK</b> Telephone preparation kit (antenna, antenna attachm. cable incl.)</li> <li><input type="checkbox"/> <b>WLIFT-AD</b> Electrical window lift, automatic up/down driver side</li> <li><input checked="" type="checkbox"/> <b>WLIFT-EB</b> Electrical window lift</li> <li><input type="checkbox"/> <b>WLIFT-ME</b> Mechanical window lift</li> <li><input type="checkbox"/> <b>ISUNS-BS</b> Side interior sun visor on both sides</li> <li><input checked="" type="checkbox"/> <b>ISUNS-DS</b> Driver's side interior sun visor</li> <li><input checked="" type="checkbox"/> <b>ISUNF-B</b> Interior front sun visor without mirror</li> <li><input type="checkbox"/> <b>ISUNF-MD</b> Interior front sun visor with mirror on driver side</li> <li><input type="checkbox"/> <b>ISUNF-RE</b> Electrically operated textile interior sun blind</li> <li><input type="checkbox"/> <b>ISUNF-RM</b> Manually operated textile interior sun blind</li> <li><input type="checkbox"/> <b>ADFS</b> Two extra DIN slots in front shelf - can be fitted with card or drawer available as an accessory</li> <li><input checked="" type="checkbox"/> <b>BUPALARM</b> Reverse alarm</li> <li><input type="checkbox"/> <b>RTOLL-PK</b> Road toll PREPARATION kit for trucks operating with "Toll Collect" in Germany</li> <li><input type="checkbox"/> <b>LOADIND</b> Load indicator with central dashboard display</li> <li><input type="checkbox"/> <b>REMC-MF</b> Multi-functio wireless remote control</li> <li><input type="checkbox"/> <b>FIREXT3S</b> 3kg fire extinguisher mounted on seat base</li> <li><input type="checkbox"/> <b>WARNVEST</b> High visibility warning vest - no sleeves</li> <li><input type="checkbox"/> <b>AIDKIT</b> First aid kit</li> <li><input type="checkbox"/> <b>AIDKIT1B</b> First aid kit</li> <li><input type="checkbox"/> <b>WARNLAMP</b> Portable warning lamp</li> <li><input type="checkbox"/> <b>LAMP-IN</b> Inspection lamp</li> <li><input type="checkbox"/> <b>BULBKIT</b> Bulb and fuse kit</li> <li><input type="checkbox"/> <b>WRITEPAD</b> Writing pad</li> <li><input type="checkbox"/> <b>UPHTRI10</b> Seats: Black embossed textile insert with light grey sides, black vinyl side bolster with blue vinyl side insert.<br/>Interior trim: Raven black bunk and curtains &amp; blue textile side walls</li> <li><input checked="" type="checkbox"/> <b>UPHTRI11</b> Seats: Light grey embossed textile insert, black raven metallic vinyl bolster with red vinyl side insert.<br/>Interior trim: Raven black bunk and curtains &amp; grey vinyl side walls</li> <li><input type="checkbox"/> <b>UPHTRI12</b> Seats: Blue soft textile insert, black vinyl bolster.<br/>Interior trim: Raven black bunk and curtains &amp; blue textile side walls</li> <li><input type="checkbox"/> <b>UPHTRI13</b> Seats: Dark grey leather insert and black leather bolster.<br/>Interior trim: Raven black bunk and curtains &amp; grey vinyl side walls</li> <li><input type="checkbox"/> <b>UPHTRI14</b> Seat: Dark grey leather insert and black leather bolster.<br/>Interior trim: Raven black bunk and curtains &amp; blue textile side walls</li> <li><input checked="" type="checkbox"/> <b>DST-CF4</b> Driver seat, comfort, suspended, belt in seat</li> <li><input checked="" type="checkbox"/> <b>DST-CF5</b> Driver seat, comfort, suspended, belt in seat, electrically heated</li> <li><input type="checkbox"/> <b>DST-CF6</b> Driver seat, comfort, suspended, belt in seat, electrically heated, ventilated</li> <li><input type="checkbox"/> <b>SBD-RED</b> Red seat belts</li> <li><input type="checkbox"/> <b>SBPRE-DS</b> Driver seat belt pretensioner</li> <li><input checked="" type="checkbox"/> <b>PST-BAS1</b> Passenger seat - Fixed non suspended fold up with seatbelt mounted in cab</li> <li><input type="checkbox"/> <b>PST-BENC</b> Bench passenger seat</li> <li><input type="checkbox"/> <b>PST-CF4</b> Passenger seat - Comfort suspended with seatbelt mounted in seat</li> <li><input type="checkbox"/> <b>PST-CF5</b> Passenger seat - Comfort suspended &amp; heated with seatbelt mounted in seat</li> <li><input type="checkbox"/> <b>PST-STD2</b> Passenger seat - Fixed non suspended with seatbelt mounted in cab</li> <li><input type="checkbox"/> <b>PST-STD4</b> Passenger seat - Standard suspended with seatbelt mounted in cab</li> <li><input type="checkbox"/> <b>SBPRE-PS</b> Passenger seat belt pretensioner</li> <li><input type="checkbox"/> <b>ARM-DBPS</b> Two armrests on driver seat and one (outer) on passenger</li> </ul> |
|--|--|

Standard Equipment       Optional Equipment

For more detailed information about cab and powertrain equipment, please refer to separate specification sheets.

For all possible options and combinations of options please consult your Volvo sales contact who can create a specification to match your requirements using the Volvo Sales Support system (VSS).

The factory reserves the right to modify design and change equipment without previous notification. The specification can vary from country to country.

# MODEL RANGE

## FMX13 6x4 Rigid - Rear Air Suspension - N3 Cranked front axle for on road work FM 64

<input type="checkbox"/>	<b>ARMRE-BB</b>	Two armrests on both driver and passenger seat.	<input type="checkbox"/>	<b>AS-FUS</b>	Extra shelf in front upper storage compartments
<input type="checkbox"/>	<b>ARMRE-DB</b>	Two armrests, on driver seat only	<input type="checkbox"/>	<b>INFOT-PK</b>	Preparation kit for the mounting of a flat screen TV in cab above the driver's door, includes bracket, electrical and speaker connections
<input type="checkbox"/>	<b>ARMRE-PB</b>	Two armrests, on passenger seat only	<b>CAB EXTERIOR</b>		
<input type="checkbox"/>	<b>ARMRE-PS</b>	Single armrest (next to driver) on passenger seat	<input checked="" type="checkbox"/>	<b>PAICS-B</b>	Basic cab paint - mirrors, sunvisor, instep and bumper supplied in natural finish - grey
<input type="checkbox"/>	<b>ARU-BAS</b>	Vinyl upholstered armrest	<input checked="" type="checkbox"/>	<b>GLAS-TIN</b>	Tinted windows.
<input type="checkbox"/>	<b>ARU-LEA</b>	Leather upholstered armrest	<input type="checkbox"/>	<b>AWIND-RF</b>	Rear window
<input checked="" type="checkbox"/>	<b>FMAT-RU2</b>	Rubber floor mats, extended	<input type="checkbox"/>	<b>DGLAS-L</b>	Laminated door glass
<input type="checkbox"/>	<b>FMAT-RUB</b>	Rubber floor mats	<input checked="" type="checkbox"/>	<b>LOCK-MAN</b>	Manual door locking
<input type="checkbox"/>	<b>FMAT-T2E</b>		<input type="checkbox"/>	<b>LOCK-MRP</b>	Manual door locking with internal remote control (from driver side) of passenger door
<input type="checkbox"/>	<b>FMAT-TX2</b>	Textile and rubber floor mats	<input type="checkbox"/>	<b>LOCK-REM</b>	Central locking with remote control
<input type="checkbox"/>	<b>LBK-RES</b>	Foldable rest bunk	<input checked="" type="checkbox"/>	<b>BUMP-HD</b>	Heavy duty front bumper
<input type="checkbox"/>	<b>LBK70</b>	Lower bunk 700 x 2000 mm, fixed	<input type="checkbox"/>	<b>GUARD-EH</b>	Engine guard to protect sump and engine hoses
<input checked="" type="checkbox"/>	<b>ULBK</b>	Without lower bunk	<input checked="" type="checkbox"/>	<b>BUGNET</b>	Insect screen in front of radiator
<input type="checkbox"/>	<b>MATL-FI</b>	Firm lower bunk pocket sprung mattress	<input type="checkbox"/>	<b>CTILTP-E</b>	Electrically operated hydraulic cab tilt
<input type="checkbox"/>	<b>MATL-SF</b>	Lower flexizone mattress - semi-firm, pocket springs up to 100kg - 16 stone	<input checked="" type="checkbox"/>	<b>CTILTP-M</b>	Manually operated hydraulic cab tilt
<input type="checkbox"/>	<b>MATL-SO</b>	Lower flexizone mattress - soft, pocket springs up to 85kg - 13.5 stone	<input type="checkbox"/>	<b>FCABS-A</b>	Front cab suspension - Air
<input type="checkbox"/>	<b>OLMAT-BA</b>	35mm mattress overlay protector	<input checked="" type="checkbox"/>	<b>FCABS-M</b>	Front cab suspension - Mechanical spring
<input type="checkbox"/>	<b>OLMAT-PR</b>	50mm premium mattress overlay protector	<input type="checkbox"/>	<b>RCABS-A</b>	Rear cab suspension - Air
<input type="checkbox"/>	<b>TBK60F</b>	Fixed foldable top bunk 600 x 1900mm	<input checked="" type="checkbox"/>	<b>RCABS-M</b>	Rear cab suspension - Mechanical spring
<input type="checkbox"/>	<b>TBK70F</b>	Fixed foldable top bunk 700 x 1900mm	<input type="checkbox"/>	<b>MIRCOMFX</b>	Electrically heated and operated -FMX- main and wide-angle mirrors with manually adjusted passenger kerb mirror, to increase direct vision to the side the main mirrors have no cowlings
<input type="checkbox"/>	<b>PH-CAB2</b>	1.8kW Air to air night heater	<input checked="" type="checkbox"/>	<b>MIRSTDX</b>	Electrically heated -FMX- main and wide-angle mirrors with manually adjusted passenger kerb mirror, to increase direct vision to the side the main mirrors have no cowlings
<input type="checkbox"/>	<b>PH-ENGCA</b>	Engine and cab night heater	<input checked="" type="checkbox"/>	<b>AMIR-F20</b>	Auxiliary front view mirror with a 200mm radius
<input type="checkbox"/>	<b>PH-SS</b>	Short stop heater	<input type="checkbox"/>	<b>SUNV-H</b>	External smoke grey sunvisor
<input type="checkbox"/>	<b>SLCP-BAS</b>	Basic sleeper control panel - includes interior light, parking heater, roof hatch and door lock	<input type="checkbox"/>	<b>AD-ROOF</b>	Roof air deflector
<input type="checkbox"/>	<b>SAFE</b>	Safe box for driver's personal items	<input type="checkbox"/>	<b>AD-SIDEL</b>	Side air deflector extension panels
<input type="checkbox"/>	<b>ETSB-F</b>	Storage on engine tunnel - on front top	<input type="checkbox"/>	<b>AD-SIDES</b>	Short cab side air deflector for rigid bodywork
<input type="checkbox"/>	<b>ETSB-FR</b>	Storage on engine tunnel - on front top and at rear cab wall	<input checked="" type="checkbox"/>	<b>HL-BAS2</b>	Halogen H1 head lamps
<input type="checkbox"/>	<b>ETSB-FRS</b>	Storage on engine tunnel - on front top & at rear cab wall & storage recessed into tunnel on right hand side	<input type="checkbox"/>	<b>HL-BASIC</b>	Halogen H7 head lamps
<input type="checkbox"/>	<b>ETSB-FS</b>	Storage on engine tunnel - on front top and storage recessed into tunnel on right hand side	<input type="checkbox"/>	<b>HL-BHID2</b>	Dynamic high intensity Bi-Xenon head lamps
<input type="checkbox"/>	<b>ETSB-R</b>	Storage on engine tunnel - box at rear cab wall	These follow the steering movement and direction of the truck		
<input type="checkbox"/>	<b>ETSB-RS</b>	Storage on engine tunnel - at rear cab wall and storage recessed into tunnel on right hand side	<input type="checkbox"/>	<b>HL-CLEAN</b>	Head lamp cleaner - washer jets
<input type="checkbox"/>	<b>ETSB-S</b>	Storage on engine tunnel - recessed into tunnel on right hand side	<input type="checkbox"/>	<b>HLP-ST</b>	Headlamp protection
<input type="checkbox"/>	<b>RUS-BAS</b>	Rear cab upper storage 154 litres - 300 mm high	<input type="checkbox"/>	<b>HL-ADJ</b>	Headlight adjustment - Switch in cab
<input type="checkbox"/>	<b>RUS-HIG</b>	Rear cab upper storage 245 litres - 440 mm high	<input checked="" type="checkbox"/>	<b>UDRIVL</b>	Without auxiliary driving lights
<input type="checkbox"/>	<b>TABLE</b>	Folding and height adjustable table - on lower bunk	<input type="checkbox"/>	<b>ASL-RF2</b>	Two Hella H11 70W spotlamps in sign box - only available with the basic headlight and no lower driving lights.
<input type="checkbox"/>	<b>REF-ICPK</b>	Fridge: engine tunnel mounted preparation kit	<input type="checkbox"/>	<b>ASL-RFPK</b>	Preparation kit for two spotlamps in sign box
<input type="checkbox"/>	<b>REFR-RUS</b>	Fridge: 28 litre rear upper wall mounted with dividers	<input type="checkbox"/>	<b>BEACOA2F</b>	Two front roof mounted amber beacon rotating warning lamps
<input type="checkbox"/>	<b>MICRO-PK</b>	Preparation kit for microwave oven (wiring)	<input type="checkbox"/>	<b>BEACOA2R</b>	Two rear roof mounted (on accessory bracket) amber beacon flashing warning LED lamps
<input type="checkbox"/>	<b>BOTH-D</b>	One bottle holder under dashboard centre section	<input type="checkbox"/>	<b>BEACON-P</b>	Roof beacon wire preparation
<input type="checkbox"/>	<b>COFMA-PK</b>	Coffee maker, preparation kit.	<input type="checkbox"/>	<b>BEACONA4</b>	Four roof mounted (2 front/2 rear) amber beacon rotating warning lamps
<input checked="" type="checkbox"/>	<b>INLI-BAS</b>	Interior white LED lights - basic	<input type="checkbox"/>	<b>CABPT-R1</b>	Single outlet for roof mounted accessories
<input type="checkbox"/>	<b>INLI-NL</b>	Interior white and red night LED light with no dimmer	<input checked="" type="checkbox"/>	<b>CABPT-R2</b>	Twin outlets for roof mounted accessories.
<input type="checkbox"/>	<b>INLI-NLD</b>	Interior white and red night LED light with dimmer	<input type="checkbox"/>	<b>SPOTP-F</b>	Spotlamp preparation in front, max 280W
<input type="checkbox"/>	<b>ARL-FLEX</b>	Two flexible reading lamps (snake lamps)	<input type="checkbox"/>	<b>SPOTP-R</b>	Spotlamp preparation on roof, max 280W
<input type="checkbox"/>	<b>RH-EE</b>	Without roof hatch -Tinted glass emergency exit ONLY	<input type="checkbox"/>	<b>SPOTP-RF</b>	Spotlamp preparation on cab roof and in cab front, max 2x280W
<input type="checkbox"/>	<b>RH-ETR</b>	Glass roof & escape hatch - Electrically operated, tinted glass with rear opening	<input type="checkbox"/>	<b>ROS-IL2</b>	Preparation kit for illuminated roof sign with switch loose in
<input type="checkbox"/>	<b>RH-MSR</b>	Steel roof & escape hatch - Manually operated with rear opening			
<input type="checkbox"/>	<b>RH-MTR</b>	Glass roof & escape hatch - Manually operated, tinted glass with rear opening			
<input checked="" type="checkbox"/>	<b>URH</b>	Without roof hatch			
<input type="checkbox"/>	<b>SWIND-BS</b>	Extra side window on both sides behind "B" pillar			
<input type="checkbox"/>	<b>SWIND-PS</b>	Rear side window, passenger side			
<input type="checkbox"/>	<b>VANMIR</b>	Vanity mirror in front shelf			

Standard Equipment

Optional Equipment

For more detailed information about cab and powertrain equipment, please refer to separate specification sheets.

For all possible options and combinations of options please consult your Volvo sales contact who can create a specification to match your requirements using the Volvo Sales Support system (VSS).

The factory reserves the right to modify design and change equipment without previous notification. The specification can vary from country to country.

# MODEL RANGE

## FMX13 6x4 Rigid - Rear Air Suspension - N3 Cranked front axle for on road work FM 64

- cab, fit after registration
- CSGN-FMX** "Volvo FMX" headboard logo
- HORN-F1S** Single tone Jericho air horn chassis mounted
- HORN-R2S** Two roof mounted air horns
- ANT-CBR** Roof mounted antenna for CB radio, single aerial
- ACCBR-AP** Front, middle & rear roof mounted accessory brackets
- ACCBR-F** Front roof mounted accessory bracket
- ACCBR-FM** Front & middle roof mounted accessory brackets
- ACCBR-FR** Front & rear roof mounted accessory brackets
- ACCBR-M** Middle roof mounted accessory bracket
- ACCBR-R** Rear roof mounted accessory bracket
- ACCBR-RM** Rear & middle roof mounted accessory brackets
- REFS-CW** White cab conspicuity markings mounted on cab side
- REFS-TW** White cab conspicuity markings by packed in cab
- REFS-TY** Yellow cab conspicuity markings by packed in cab
- CRANEPK4** Crane plates mounted to frame, for cranes up to 40 tonne metre capacity
- AUXL-SPK** Electrical preparation kit - wiring and switch for snow plough lights
- TAILPRE2** Tail lift preparation kit, wireless remote operation
- TAILPREP** Taillift preparation kit - cab switch and warning in driver display
- AESW2** Two Body builder bistable electrical switches (marked AUX1 / AUX2)
- AESW2PK** 2 Body builder bistable el.switches (marked AUX1/AUX2) and prep. for 4 more switches
- AUXSW-4** Wiring for 4 extra switches (from Body builder electrical centre to switch positions)

### DELIVERY SERVICES

- TGW-4GWL** GSM/GPRS/4G modem, LTE & WLAN for telematics gateway
- FMS-PK** Fleet Management System gateway

### SUPERSTRUCTURE PREPARATIONS

- BP-MI02**
- BP-TI03**
- CROSSRE** Cross reinforcement for swapbody
- SRWL-PK** Wiring preparation for side & rear work/reverse lamps on side of chassis and a three-position switch, maximum 280W
- SWL-2FW** Two H3 70W white front chassis mounted (LH/RH side) working lamps and a 2-position switch (On/Off)
- SWL-2RW** Two H3 70W white rear chassis mounted (LH/RH side) working lamps and a 2-position switch (On/Off)
- SWL-4W** 4 H3 70W white front (2) & rear (2) chassis mtd (LH/RH side) working lamps & 2-pos switch (On/Off)
- SWL-PK** Wiring preparation for side work/reverse lamps on side of chassis and a three-position switch, maximum 280W
- WLC-H2A** Two H3/70W working lamps with amber coloured lens high mounted back of cab
- WLC-H2W** Two H3/70W white working lamps high mounted on the back of cab
- WLC-PKCH** Preparation kit (cables and switch) for cab mounted chassis working lamp
- WLC-PKH** Preparation kit, cables and switch for high mounted working lamps back of cab
- WLC-PKL** Preparation kit, cables and switch for low mounted working lamps back of cab
- WLC-PKLH** Preparation kit - cables and switch for low and high mounted working lamps back of cab.
- ECBB-BAS** Body builder electrical centre without body builder module
- ECBB-HIG** Body builder electrical centre with body builder module
- BBCHAS1** One 7-pole connector for Body builder interface
- BBCHAS3** Three 7-pole connectors for Body builder interface
- BEPR-T2** Body builder electrical software preparation for tipper with remote control
- EXSTER** External steering control, with VDS and bodybuilder module
- TD-BAS** Trailer detection WITHOUT LED sensing
- TD-LED** Trailer detection with LED sensing
- FRFS-BS** Frame rail free space on both sides to give space for crane legs or other equipment.
- FBA-BTF** Lower front body attachments for torsionally flexible - platform body
- FBA-BTSF** Lower front body attachments for torsionally semi-flexible body - box or curtainsider
- HBA-FSFB** Holes for body attachments - flexible/semi-flexible body
- HBA-SB** Holes for body attachments - stiff body
- RBA-T2** Lower rear body attachments for helper frame
- CRANEPK1** Crane plates mounted to frame, for cranes up to 10 tonne metre capacity
- CRANEPK2** Crane plates mounted to frame, for cranes up to 20 tonne metre capacity

**VOLVO**

Volvo Truck Corporation

volvotrucks.com