

MODEL RANGE

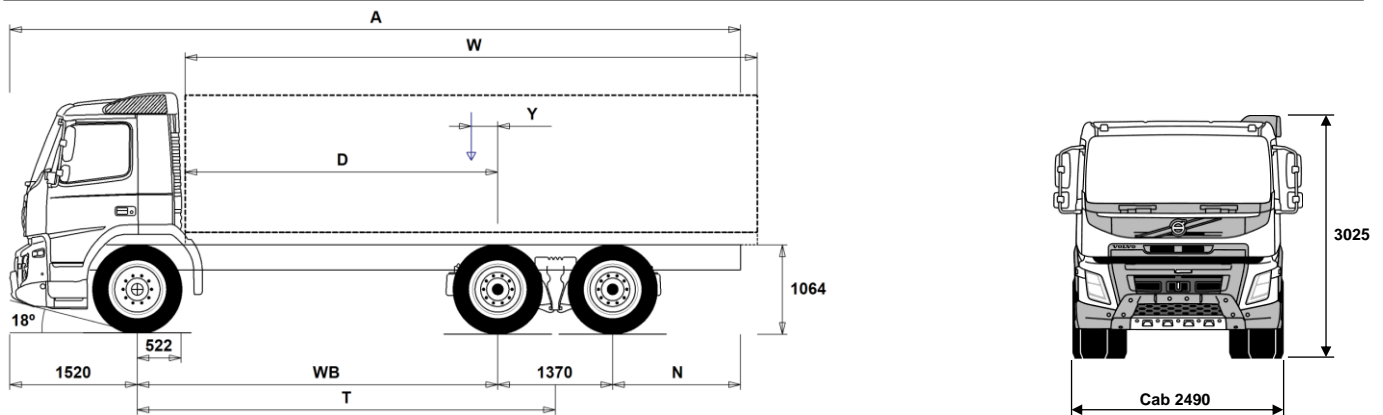

Volvo Trucks. Driving Progress

FMX D13 64 Rigid rear air FM 64 R3HAX



Chassis Dimensions [mm]

WB Wheelbase	3200	3400	3700	3900	4300	4600	4900	5200	5600
A Overall Chassis Length	7865	8165	8615	8915	9565	10015	10465	10965	11565
D Center of rear axle to front of body	2628	2828	3128	3328	3728	4028	4328	4628	5028
N Rear Overhang (Min.)	1225	1225	1225	1225	1225	1225	1225	1225	1225
N Rear Overhang (Max.)	1775	1875	2025	2125	2375	2525	2675	2875	3075
T Theoretical Wheelbase	3885	4085	4385	4585	4985	5285	5585	5885	6285
Y Center of Gravity for Payload (Min.)	-32	0	48	80	144	191	237	286	347
Y Center of Gravity for Payload (Max.)	-32	0	48	80	144	191	237	286	347
W Body Length (Min.)	5340	5676	6180	6516	7189	7694	8202	8705	9382
W Body Length (Max.)	5340	5676	6180	6516	7189	7694	8202	8705	9382

Chassis Weights [kg]

Front Axle	4510	4520	4535	4545	4565	4575	4600	4605	4630
Rear Bogie	3415	3425	3450	3460	3505	3535	3575	3605	3640
Kerb Weight	7925	7945	7985	8005	8070	8110	8175	8210	8270
Payload (including body, driver, fuel, etc.)	21075	21055	21015	20995	20930	20890	20825	20790	20730

Turning Diameter [mm]

Turning Circle Diameter Kerb to Kerb	13900	14500	15500	16100	17300	18200	19100	20000	21300
Turning Circle Diameter Wall to Wall	15400	16000	16900	17500	18800	19700	20600	21500	22800

Plated Weights [kg]

Gross Vehicle Weight	29000
Gross Combination Weight	44000
Front Axle	8000
Rear Bogie	21000

Design

Important Notes

Chassis Dimensions

Cab Height: +416 mm for CAB-HSLP, +554 mm for CAB-XHSL.
Front Axle to Back of Cab: +424 mm for CAB-HSLP and CAB-SLP and CAB-XHSL.

D-measure includes a front clearance of 50 mm and for rigid trucks also a subframe of 100 mm.

Height can vary ± 20 mm for leaf and ± 10 mm for air suspension.

All dimensions are for unladen chassis and any tag axles down. Chassis height used: CHH-HIGH.

Rear overhang used for vehicle weight calculation is the maximum rear overhang (N Max.) for selected wheelbase.

Height change when chassis height CHH-MED, FRAME300: 0 mm.

Weight and dimensions are based upon the following tyres:

Front Axle Tyres: 315/80R22.5
Drive Axle Tyres: 315/80R22.5

Chassis weight includes oil, water, AdBlue, 0 litres fuel and without driver. Kerb weight can vary $\pm 3\%$.

Turning diameters are theoretically calculated.

Legal weights can differ from country to country.

For more detailed weight information, including optional equipment weights, ask your Volvo sales contact to enter your specification into the Volvo Weight Information system (WIS).

Do NOT use this drawing for bodybuilding. Refer to Volvo Bodybuilder Instructions and chassis assembly drawing FM64R3HAX.

MODEL RANGE

FMX D13 64 Rigid rear air FM 64 R3HAX

Transport operation

- PTO-HT16** High torque Power take-off 1600Nm
- PTO-HT20** High torque Power take-off 2000Nm
- RC-ROUGH** Rough road conditions.
 - Less than 95% of the driven distance on well maintained or less maintained surfaced roads.
 - and / or
 - In total not more than 5% of the driven distance on:
 - Very badly maintained surfaced roads.
 - Hard packed sand or gravel surface of very bad quality.
 - Washboards.
 - Soft unpaved surface.
 - Off-road.
- RC-SMOOT** Smooth road conditions.
At least 95% of the driven distance on well maintained or less maintained surfaced roads.
Driving occurs on:
 - Badly maintained surfaced roads.
 - Hard packed sand or gravel surface of good or bad quality.
- GARB-PRE** Garbage preparation
- SWAPBODY** Swap body vehicle preparation
- TIPP-PRE** Tipper vehicle preparation
- UNIFORM** Basic platform vehicle

Core components

- CHH-HIGH** Chassis height high - approx. 1000 mm above ground level
- CHH-MED** Chassis height medium - approx. 900 mm above ground level
- RADD-GR** Rear air suspension, 2 axles - 2 driven
- FMX-DAY** FMX Day cab
- FMX-HSLP** FMX Globetrotter sleeper cab
- FMX-SLP** FMX Sleeper cab
- EU6SCR** Euro 6 emission level with Selective Catalytic Reduction (SCR), particulate filter and Exhaust Gas Recirculation (EGR)
- D13 420S** Diesel engine with Turbo-S, 12.8 litre Euro 6 SCR + EGR (Diesel Particulate Filter), 420 hp, 2100 Nm
- D13 460S** Diesel engine with Turbo-S, 12.8 litre Euro 6 SCR + EGR (Diesel Particulate Filter), 460 hp, 2300 Nm
- D13 500S** Diesel engine with Turbo-S, 12.8 litre Euro 6 SCR + EGR (Diesel Particulate Filter), 500 hp, 2500 Nm
- D13 540S** Diesel engine Turbo-S, 12.8 litre Euro 6 SCR + EGR (Diesel Particulate Filter), 540 hp, 2600 Nm
- D13K420** Diesel engine, 12.8 litre Euro 6 SCR + EGR (Diesel Particulate Filter), 420 hp
- D13K460** Diesel engine, 12.8 litre Euro 6 SCR + EGR (Diesel Particulate Filter), 460 hp
- D13K500** Diesel engine, 12.8 litre Euro 6 SCR + EGR (Diesel Particulate Filter), 500 hp.
- D13K540** Diesel engine, 12.8 litre Euro 6 SCR + EGR (Diesel Particulate Filter), 540 hp
- DIESEL** Diesel fuel
- DIESEL-B** Biodiesel
- EBR-EPG** Engine brake with exhaust pressure governor, EPG
- EBR-EPGC** Volvo engine compression brake with exhaust pressure governor, EPG (for I-shift)
- EBR-VEB** Volvo Engine Brake, VEB (compression brake with exhaust pressure governor, EPG)
- EBR-VEB+** Volvo Engine Brake, VEB+ (high efficiency compression brake with exhaust pressure governor, EPG)
- AT2412F** I-Shift automated mechanical 12-speed gearbox without clutch pedal, max. engine torque 2400 Nm, max. permitted GCW 44000 kg.
- AT2612F** I-Shift automated mechanical 12-speed gearbox without clutch pedal, max. engine torque 2600 Nm, max. permitted GCW 100000 kg.
- ATO2612F** I-Shift automated mechanical 12-speed overdrive gearbox without clutch, max. engine torque 2600 Nm, max. permitted GCW 100000 kg.
Suitable for hub reduction rear axles.
- PT2606** Powertronic automatic 6-speed gearbox, max. engine torque

Standard Equipment

Optional Equipment

For more detailed information about cab and powertrain equipment, please refer to separate specification sheets.

For all possible options and combinations of options please consult your Volvo sales contact who can create a specification to match your requirements using the Volvo Sales Support system (VSS).

The factory reserves the right to modify design and change equipment without previous notification. The specification can vary from country to country.

- SPO2812** 2600 Nm, max. permitted GCW 130000 kg
Semi power shift dual clutch 12-speed overdrive gearbox, max. engine torque 2800 Nm, max permitted GCW 80 000 kg.
- TAAXLIFT** Tandem axle lift for driven bogie axle
- RTH2610F** Rear hub reduction tandem axles - bogie load 26 tonnes, GCW 100 tonnes, version F
- RTS2310A** Rear single reduction tandem axle - bogie load 23 tonnes, GCW100 tonnes
- RTS2370A** Rear single reduction tandem axles - bogie load 23 tonnes, GCW 70 tonnes

Packages

- EDITION** Exterior Striping/Emblem. Model specific design on FH,FM,FH16 and FMX
- DRIVEFM** Driving package FM
- DRIVEFM+** Driving plus package FM
- BEDFM** Bed resting package FM
- AUDBAS** Audio basic. RDS radio with CD player, FM/AM antenna and speakers in dashboard & doors.
Prepared for Dynafleet office internet portal support.
High power audio system. RDS radio with CD player (also playing mp3/wma/wav files from CD), FM/AM antenna, speakers in dashboard & doors & sleeping compartment, integrated bluetooth phone and USB/Line inputs.
Prepared for Dynafleet office internet portal support.
- AUDHIG** Media package with infotainment. Prepared for both Dynafleet vehicle onboard support and for Dynafleet office internet portal support.
- MEDIADF** Media package with infotainment and Navigation support and prepared for Dynafleet vehicle onboard support and for Dynafleet office internet portal support.
- VISIX15** Visibility package FMX
- ASAF15** Active safety package
- ENOPT** Energy optimization package
- ENOPT+** Energy optimization+ package
- ENOPT++** Energy optimization++ package
- OFFRFMXD** Construction package for FMX day cab
- OFFRFMXS** Construction package for FMX sleeper cabs
- RCHAPAC1** Rigid chassis package

Chassis

- FST-AIR** Front air suspension
- FST-PAR** 2 leaf front parabolic suspension (normal stiffness)
- FST-PAR3** 3 leaf front parabolic suspension (stiffer than normal)
- FSL-S-BAS** Front air suspension basic levelling stroke
- FSL-S-HI** Front air suspension high levelling stroke
- FAL10.0** Front axle load 10.0 tonnes
- FAL7.1** Front axle load 7.1 tonnes
- FAL7.5** Front axle load 7.5 tonnes
- FAL8.0** Front axle load 8.0 tonnes
- FAL8.5** Front axle load 8.5 tonnes
- FAL9.0** Front axle load 9.0 tonnes
- FALIM** Front axle load limiter
- FSTAB** Front stabilizer with normal stiffness
- FSTAB2** Front stabilizer with medium high stiffness
- FSTAB3** Front stiff stabilizer
- RAL21** Rear axles load 21 tonnes
- RAL23** Rear axles load 23 tonnes
- RAL26** Rear axles load 26 tonnes
- RSTAB1** Rear stabilizer with normal stiffness
- RSTAB3** Rear stiff stabilizer
- RALIM105** First rear drive axle load limiter, 10.5 tonnes (speed controlled)
- RALIM115** First rear drive axle load limiter, 11.5 tonnes (speed controlled)
- RALIM13** First rear drive axle load limiter, 13 tonnes
- RALIM95** First rear drive axle load limiter, 9.5 tonnes

MODEL RANGE

FMX D13 64 Rigid rear air FM 64 R3HAX

- **ASF-DL1** Air suspension with 1 driving level
- **ACTST-TO** Volvo Dynamic Steering (VDS) with extra pump and torque overlay
- **ASFE-BAS** Volvo Dynamic Steering feature basic
- **ASFE-PS** Volvo Dynamic Steering personal settings
- **PSS-SING** Single power steering system
- **PSP-FIX** Power steering pump with fixed displacement
- **PSP-VAR** Power steering pump with variable displacement
- **EBS-MED** EBS (Electronic Brake System) medium package:
 - ABS (Anti-lock Braking System)
 - Lining Wear Sensing (20 % left)
 - Lining Wear Control (incl. wear on the axle)
 - Brake Blending
 - Drag Torque Control
 - Diff Lock Synchronization
 - Diff lock Control
 - Brake Temperature Warning
 - External Brake Demand
 - Diagnosis Via Truck Electronic System
 - Traction Control System
 - Emergency Brake Assistance
 - Constant Wheel Brake Monitoring
 - Coupling Force Control
 - Automatic Parking Brake Activation
 - Lining Wear Analyses (calc of remaining mileage)
 - Hill Starting Assistance
 - EBS status monitoring via Truck Electronic System
- **AUXPARK** Two extra parking brake chambers
- **FBREG-E** Front axle regulating brake valve for EBS
- **SUSPL-EC** Air suspension levelling with electronic control
- **FRAME266** Frame rail section external height 266 mm
- **FRAME300** Frame rail section external height 300 mm
- **FST7070** Frame section thickness - web 7.0 mm / flange 7.0 mm
- **FST8080** Frame section thickness - web 8.0 mm / flange 8.0 mm
- **FIL-EEEB** Frame inner liner from end of engine end to end of bogie
- **FIL-EEEF** Frame inner liner from end of engine end to end of frame
- **FIL-FBEB** Frame inner liner from front of bogie to end of bogie
- **FIL-FBEF** Frame inner liner from front of bogie to end of frame
- **FIL-TXEB** Frame inner liner from transmission cross member to end of bogie
- **FIL-TXEF** Frame inner liner from transmission cross member to end of frame
- **BBOX-L** Battery box on left hand side
- **BATS-D** Dual energy battery storage system (2 living batteries and 2 starter batteries)
- **BATS-S** Single energy battery storage system (2 batteries)
 - **2BAT210B** Gel batteries 2x210 Ah
 - **2BATT170** Batteries 2x170 Ah
 - **2BATT225** Batteries 2x225 Ah
- **BATTAMP** Battery voltage and ampere gauge
- **BATTIND** Battery voltage, ampere and battery status gauge with visual alerts
- **ADR2** ADR adaptation - transportation of dangerous goods, 2 switches (1 inside cab in dashboard, 1 outside on cab back passenger side).
- **MSWI-A** ADR main switch - ADR switch circuit shut down
- **MSWI-C** Chassis main switch - battery box placed toggle switch circuit shut down
- **MSWI-R** Remote controlled main switch - key fob operated circuit shut down
- **R365A71** Right 365 litre aluminium 710 mm high D-shaped diesel tank. Usable volume is 97% of stated volume. Min volume 255l Max volume 885l
- **UL-FUEL** Without left diesel tank
Min volume 160l
Max volume 730l
- **ADTP-L** AdBlue tank on left hand side (for dual front axles between the axles)
- **ADTP-R** AdBlue tank on right hand side
- **ADB048** AdBlue tank usable volume 48 litres
- **ADB064** AdBlue tank usable volume 64 litres
- **ADB068** AdBlue tank usable volume 68 litres
- **ADB090** AdBlue tank usable volume 90 litres
- **ADB100** AdBlue tank usable volume 100 litres
- **ADTC-BF** AdBlue tank cover painted in silver metallic
- **FCAP-L** Lockable diesel and AdBlue tank caps
- **FUFF-AS** Fuel filling anti-spillage device
- **FUFF-ATS** Fuel filling anti-theft and anti-spillage devices
- **ESH-LEFT** Horizontal muffler, left exhaust outlet
- **ESH-REAR** Horizontal muffler, rear exhaust outlet
- **ESH-VERT** Horizontal muffler, vertical exhaust outlet on right hand side
- **ESV-VERT** Vertical muffler, vertical exhaust outlet on right hand side
- **EXST-SSP** Bright polished vertical stainless steel exhaust top pipe
- **EXST-ST** Aluminized steel vertical exhaust top pipe
- **HS-NAR** Narrow Euro 6 muffler heat shield. Partly (due to heat release) reduced distance (moved inwards) to silencer. Makes better space for e.g. support legs.
- **WHC-FIX2** Two fixed wheel chocks
- **WHC-FOL2** 2 foldable wheel chocks
- **WHCP-F** Wheel chock(s) in the front part of the vehicle.
 - TRACTOR, BBOX-L, Fold, 1/2 w chocks = Top of left side battery box
 - TRACTOR, BBOX-EF, Fold, 1/2 w chocks = Top of lefts side fuel tank
 - TRACTOR, BBOX-EF, Fix, 2 w chocks = Left frame front of fuel tank
 - RIGID, 1 front axle, Fold, 1/2 w chocks = Top of left side battery box
 - RIGID, 2 front axles, Fold, Frame free space, 2 wc = Top of left side battery box
 - RIGID, 2 front axles, Fix, W/o frame free space, 2 wc = Left frame behind 1st front wheel
- **WHCP-M** Wheel chock(s) in the middle part of the vehicle
 - TRACTOR, BBOX-L, Fix, 1/2 w chocks = Left frame front of rear wheels
 - RIGID, 1 front axle, Fix, 1/2 w chocks = Left frame front of (or behind) rear wheels
- **WHCP-R** Wheel chock(s) in the rear part of the vehicle
 - RIGID, 1 front axle, Fix, 1/2 w chocks = Left frame rear (or front) of rear wheels
- **WHCP-T** Transport mounted wheel chock(s) in cab outer luggage compartment
- **TB-L80** Left toolbox 800 mm length (mounting length 800 mm, real length 730 mm)
- **TB-R80** Right toolbox 800 mm length (mounting length 800 mm, real length 730 mm)
- **SUP-BAS** Standard aluminium bars for side underrun protection
- **CHAIN-S** Snow chains
- **HOOK-SC** Snow chain hooks. Rear mounted for tractors and side mounted in rear overhang for rigids. Two hooks on each side.
- **TOWF-HD1** One heavy duty front towing device
 - **TOWMBRH** High mounted towing member, in centre of frame
 - **TOWMBRL1** Towing member, low mounted under the frame (position 1)
 - **TOWMBRL2** Towing member, low and forward mounted under the frame (position 2)
 - **TOWMBRL3** Towing member, low and far forward mounted under the frame, (position 3)
 - **TOWMBRM** Towing member, medium mounted in line with frame lower

■ Standard Equipment

□ Optional Equipment

For more detailed information about cab and powertrain equipment, please refer to separate specification sheets.

For all possible options and combinations of options please consult your Volvo sales contact who can create a specification to match your requirements using the Volvo Sales Support system (VSS).

The factory reserves the right to modify design and change equipment without previous notification. The specification can vary from country to country.

MODEL RANGE

FMX D13 64 Rigid rear air FM 64 R3HAX

	flange		
<input type="checkbox"/>	RFEC-L	Rear frame end, lower cut (for centre axle drawbar)	
<input checked="" type="checkbox"/>	RFEC-S	Rear frame end, straight cut (for regular platform applications)	
<input type="checkbox"/>	RFEC-U	Rear frame end, upper cut (for e.g. tipper, refuse and hooklift applications)	
<input type="checkbox"/>	C-RI4040	Towing coupling Ringfeder RF4040A G-150	
<input type="checkbox"/>	C-RI4045	Towing coupling Ringfeder RF4045A G-150	
<input type="checkbox"/>	C-RI5055	Towing coupling Ringfeder RF5055A G-150	
<input type="checkbox"/>	C-RO400G	Towing coupling Rockinger 400 G-150	
<input type="checkbox"/>	C-RO50	Towing coupling Rockinger 50 mm	
<input type="checkbox"/>	C-VBG750	Towing coupling VBG 750V	
<input type="checkbox"/>	C-VBG850	Towing coupling VBG 8500	
<input type="checkbox"/>	TOWR-ONE	One rear towing device in frame end cross member	
<input checked="" type="checkbox"/>	TREL-PK	Trailer electrical preparation kit (chassis/cab wiring)	
<input type="checkbox"/>	TREL15	15 pol electrical trailer connector (ADR certified)	
<input type="checkbox"/>	TREL7-7	2x7 pol (24N+24S) electrical trailer connectors (UADR)	
<input type="checkbox"/>	TBC-DUO	Trailer brake connection, Duomatic	
<input type="checkbox"/>	TBC-EC	Trailer brake connection, European Community	
<input type="checkbox"/>	TRBR-STA	Stationary trailer brake control	
<input type="checkbox"/>	TRB-STRE	Automatic low speed trailer brake activation (stretch brake) to avoid jack-knifing and to improve steerability	
<input type="checkbox"/>	RUP-FOLD	Foldable aluminium rear underrun protection, EC approved	
<input type="checkbox"/>	RUP-FOSL	Foldable and slidable aluminium rear underrun protection, EC approved	
<input type="checkbox"/>	RFEND-B	Rear 3 piece fenders with anti-spray function (all rear axles)	
<input type="checkbox"/>	RFEND-T	Transport mounted one-piece rear fenders	
<input type="checkbox"/>	RFH-BAS	Optimal fender installation (rear and 2nd front axle) with regard to legal demands, wheel/tyre sizes, chassis height and fifth wheel height.	
<input type="checkbox"/>	RFH-HIG	Highest fender installation (rear and 2nd front axle). Suitable for rough and very rough road conditions.	
<input type="checkbox"/>	RFH-LOW	Lower fender installation (rear and 2nd front axle). Suitable only for smooth road conditions. Increased risk of fender top wear.	
<input type="checkbox"/>	AUXATNK	Extra air tank	
<input type="checkbox"/>	ATANK-AL	Aluminium air tanks	
<input checked="" type="checkbox"/>	ATANK-ST	Steel air tanks	
<input type="checkbox"/>	RESTS-W	Reflecting white stripes mounted on chassis side (underrun prot./toolbox/between fenders/overhang)	
<input type="checkbox"/>	REST-RUP	Reflecting red stripes mounted on rear underrun protection	
<input type="checkbox"/>	TL-LED	LED tail lamps (tail light, exterior marker light, brake light, hazard warning light, reverse light, rear fog light, licence plate light and reflector).	
<input type="checkbox"/>	BLIGHT-E	Emergency brake light	
<input type="checkbox"/>	FRACLOS	Frame end closing	
Rims and Tyres			
<input type="checkbox"/>	RT-AL	Brushed aluminium rims with std holes (long stud fixing) on all axles	
<input type="checkbox"/>	RT-ALDP	Dura-Bright polished aluminium rims with std holes (long stud fixing) on all axles	
<input type="checkbox"/>	RT-ALDPD	Dura-Bright polished aluminium rims with countersunk holes (short stud fixing) on all axles	
<input type="checkbox"/>	RT-ALDU	Brushed aluminium rims with countersunk holes (short stud fixing) on all axles	
<input checked="" type="checkbox"/>	RT-STEEL	Steel rims on all axles	
<input type="checkbox"/>	WCAP	Wheel caps	
<input type="checkbox"/>	BRREC001	Bridgestone ECOPIA H - Fuel Tyre Recommendation 1	
<input type="checkbox"/>	BRREC002	Bridgestone Ecopia H 002 Evo - Tyre recommendation 2	
<input type="checkbox"/>	COREC001	Continental ECOPLUS HS3 XL/HD3 - Fuel Tyre Recommendation 1	
<input type="checkbox"/>	COREC002	Continental ECOPLUS HS3/HD3 - Fuel Tyre Recommendation 2	
<input type="checkbox"/>	COREC003	FUEL EFFICIENCY CLASS A Continental Efficient Pro S/D -	
<input type="checkbox"/>	GYREC002	Fuel Tyre Recommendation 3 Good Year Fuelmax S Gen-2 Long Haul - Tyre Recommendation 2	
<input type="checkbox"/>	GYREC003	Good Year Fuelmax S/(O)/D - Tyre Recommendation 3	
<input type="checkbox"/>	GYREC004	Good Year Fuelmax S Gen2 - Tyre Recommendation 4	
<input type="checkbox"/>	HAREC001	Hankook AL10+ E-Cube Max Long Haul Tire Recommendation 1	
<input type="checkbox"/>	HAREC002	Hankook AL10+ E-Cube Long Haul Tire Recommendation 2	
<input type="checkbox"/>	MIREC001	Michelin XFA2/X-LINE Energy - Fuel Tyre Recommendation 1	
<input type="checkbox"/>	MIREC002	Michelin XZA2/X-LINE Energy - Fuel Tyre Recommendation 2	
<input type="checkbox"/>	MIREC003	Michelin X-LINE Energy - Fuel Tyre Recommendation 3	
<input type="checkbox"/>	MIREC004	FUEL EFFICIENCY CLASS A Michelin X Line Energy F/D2 - Fuel Tyre Recommendation 4	
<input type="checkbox"/>	PIREC001	Pirelli FH:01 Proway - Tyre Recommendation 1	
<input type="checkbox"/>	PIREC002	Pirelli FH:01 II - Tyre Recommendation 2	
<input type="checkbox"/>	SPWT-D	Spare wheel with tyre equal to drive	
<input type="checkbox"/>	SPWT-F	Spare wheel with tyre equal to front wheel	
<input type="checkbox"/>	SWCP-LF	Spare wheel carrier on left side in front of rear axle	
<input type="checkbox"/>	SWCP-R	Spare wheel carrier mounted behind rear axle and below frame	
<input type="checkbox"/>	SWCP-T	Temporary spare wheel carrier. Spare wheel is transport mounted (strapped on top of the frame rails) with plastic stripes.	
<input type="checkbox"/>	SWCP-TP	Spare wheel carrier transport mounted with the spare wheel on top of the frame rails	
<input type="checkbox"/>	JACK-12T	Jack 12 tonnes	
<input type="checkbox"/>	JACK-15T	Jack 15 tonnes	
<input checked="" type="checkbox"/>	JACK-20T	Jack 20 tonnes	
<input checked="" type="checkbox"/>	TOOL-BAS	Basic tools (combination screw driver, socket wrench)	
<input type="checkbox"/>	TOOLKIT	Extended tool kit	
<input checked="" type="checkbox"/>	INFLAHOS	Tyre inflation hose (18 metres) with nozzles in both ends	
<input type="checkbox"/>	GAUGE-TP	Tyre pressure gauge	
<input type="checkbox"/>	OBDEP-C	EU6 mandatory on board diagnostics, phase C regulations	
<input type="checkbox"/>	OBDEP-D	EU6 mandatory on board diagnostics, phase D regulations	
Powertrain equipment			
<input type="checkbox"/>	ASO-C	One crawler gear	
<input type="checkbox"/>	ASO-ULC	Two crawler gears, one ultra low crawler and one crawler	
<input type="checkbox"/>	TRAP-HD	Reinforced gearbox application. For manual gearboxes a heavy-duty nodular iron range housing. For I-shift gearboxes (2412 excl.) a reinforced gear shifting system.	
<input type="checkbox"/>	TP-BAS	I-shift City gear changing software	
<input type="checkbox"/>	TP-CON	I-shift construction gear changing software	
<input type="checkbox"/>	TP-DIST	I-shift distribution gear changing software	
<input type="checkbox"/>	TP-HD	I-shift Heavy Duty gear changing software	
<input type="checkbox"/>	TP-LONG	I-shift long haul gear changing software	
<input type="checkbox"/>	AMSO-AUT	I-shift manual gear shift available in automatic mode incl kickdown function	
<input type="checkbox"/>	AVO-ENH	Enhanced I-shift software for construction and off road applications	
<input type="checkbox"/>	APF-ENH	Enhanced I-shift PTO functions (Auto Neutral / Reverse Inhibit / Split Box Connection)	
<input type="checkbox"/>	RET-TH	Retarder (incl cooler) for manual and I-shift gearboxes with oil as brake fluid	
<input type="checkbox"/>	RET-TPT	Retarder for hydraulic gearbox	
<input type="checkbox"/>	TC-HWO	Cooler for hydraulic gearboxes - water/oil	
<input type="checkbox"/>	TC-MAOH2	Extra high performance cooler for manual/I-shift gearboxes - air/oil	
<input checked="" type="checkbox"/>	TC-MWO	Basic performance cooler for manual/I-Shift gearboxes - water/oil	
<input type="checkbox"/>	TC-MWOH2	High performance cooler for manual/I-Shift gearboxes - water/oil	
<input checked="" type="checkbox"/>	2COM1100	Dual cylinder air compressor 760 cc / 1100 l/min	
<input type="checkbox"/>	2COMP900	Dual cylinder air compressor 636 cc	
<input type="checkbox"/>	CLU-AIRC	Air compressor clutch automatically declutched when not	
<input checked="" type="checkbox"/>	Standard Equipment		
<input type="checkbox"/>	Optional Equipment		

For more detailed information about cab and powertrain equipment, please refer to separate specification sheets.

For all possible options and combinations of options please consult your Volvo sales contact who can create a specification to match your requirements using the Volvo Sales Support system (VSS).

The factory reserves the right to modify design and change equipment without previous notification. The specification can vary from country to country.

MODEL RANGE

FMX D13 64 Rigid rear air FM 64 R3HAX

	needed in order to save fuel		
■ AIRIN-HI	High air intake		
□ AIRIN-LO	Low air intake		
□ ACL1ST-S	Air cleaner with additional filter element (primary + secondary)		
■ 24AL110B	Alternator 110 Ampere		
□ 24AL120B	Alternator 120 Ampere		
□ 24AL150B	Alternator 150 Ampere		
□ CCV-C	Closed crankcase ventilation		
□ PRIM-EL	Electrical priming pump for fast and easy bleeding of the fuel system		
■ PRIM-MAN	Manual priming pump for fast and easy bleeding of the fuel system		
□ AF-R	Hot fuel recirculation heated fuel filter		
■ EST-AID	Engine start pre-heating element		
□ 220EBH15	Engine block heater, 220 volt, 1.5 kW		
□ PTER-100	Rear engine mounted clutch independent power-take-off with flange connection (DIN 100 / ISO 7646)		
□ PTER-DIN	Rear engine mounted clutch independent PTO with splined shaft groove (female) for a close coupled pump (DIN 5462 / ISO 7653)		
□ PTER1400	Rear engine mounted clutch independent power-take-off with flange connection (SAE 1410 / ISO 7647)		
□ HPE-F101	Rear engine mounted hydraulic pump F1-101, fixed displacement, single flow		
□ HPE-F41	Rear engine mounted hydraulic pump F1-41, fixed displacement, single flow		
□ HPE-F51	Rear engine mounted hydraulic pump F1-51, fixed displacement, single flow		
□ HPE-F61	Rear engine mounted hydraulic pump F1-61, fixed displacement, single flow		
□ HPE-F81	Rear engine mounted hydraulic pump F1-81, fixed displacement, single flow		
□ HPE-T53	Rear engine mounted hydraulic pump F2-53/53, fixed displacement, twin flow		
□ HPE-T70	Rear engine mounted hydraulic pump F2-70/35, fixed displacement, twin flow		
□ HPE-V45	Rear engine mounted hydraulic pump VP1-45, variable displacement, single flow		
□ HPE-V75	Rear engine mounted hydraulic pump VP1-75, variable displacement, single flow		
□ PTPT-D	Automatic gearbox driven power take-off, 1 front/upper connection (DIN 5462 / ISO 7653) for plug-in pump (max. 850 Nm).		
□ PTPT-F	Automatic gearbox driven Power take-off, 1 front/upper rear facing flange connection (SAE 1410 / ISO 7647) for propeller shaft (max. 850 Nm).		
□ PTR-D	Mechanical gearbox driven low speed power take-off, 1 rear connection (DIN 5462 / ISO 7653) for plug-in pump (max. 1000 Nm).		
□ PTR-DH	Mechanical gearbox driven high speed power take-off, 1 rear connection (DIN 5462 / ISO 7653) for plug-in pump (max. 600 Nm).		
□ PTR-DM	Mechanical gearbox driven medium speed power take-off, 1 rear connection (DIN 5462 / ISO 7653) for plug-in pump (max. 600 Nm).		
□ PTR-F	Mechanical gearbox driven low speed power take-off, 1 rear flange connection (SAE 1410 / ISO 7647) for propeller shaft (max. 1000 Nm).		
□ PTR-FH	Mechanical gearbox driven high speed power take-off, 1 rear flange connection (SAE 1310 / ISO 7647) for propeller shaft (max. 600 Nm).		
□ PTR-FL	Mechanical gearbox driven low speed power take-off, 1 rear flange connection (SAE 1310 / ISO 7647) for propeller shaft (max. 600 Nm).		
□ PTRD-D	Mechanical gearbox driven high speed power take-off, 1 rear and 1 front connections (DIN 5462 / ISO 7653) for plug-in pumps (max. 870 Nm).		
□ PTRD-D1	Mechanical gearbox driven high speed power take-off, 1 rear flange connection (SAE 1410 / ISO 7647) for propeller shaft / 1		
		front connection (DIN 5462 / ISO 7653) for plug-in pump (max. 870 Nm).	
		Mechanical gearbox driven power take-off, 2 rear flange (high-low speed) connections (SAE 1310/1410 / ISO 7647) for propeller shafts / 1 front (high speed) connection (DIN 5462 / ISO 7653) for plug-in pump (max. 870/1000 Nm).	
□ PTRD-D2		Mechanical gearbox driven high speed power take-off, 1 rear flange connection (SAE 1410 / ISO 7647) for propeller shaft (max. 870 Nm).	
□ PTRD-F			
□ HPG-F101		Gearbox mounted hydraulic pump F1-101, fixed displacement, single flow	
□ HPG-F41		Gearbox mounted hydraulic pump F1-41, fixed displacement, single flow	
□ HPG-F51		Gearbox mounted hydraulic pump F1-51, fixed displacement, single flow	
□ HPG-F61		Gearbox mounted hydraulic pump F1-61, fixed displacement, single flow	
□ HPG-F81		Gearbox mounted hydraulic pump F1-81, fixed displacement, single flow	
□ EIDLESD		Engine idle shut down	
Cab Interior, Driving			
■ STWPOS-L		Left hand drive	
□ STWM-LE		Leather steering wheel	
□ STGW-AD2		Mechanically adjustable steering wheel with neck tilt	
■ STGW-ADJ		Mechanically adjustable steering wheel	
□ AIRBAG		Airbag on driver side	
□ INST-BAS		Basic level instrument cluster - 4 inch monochrome display 240x320 pix	
□ DRC-AMII		Regeneration control of diesel filter particulates - auto initiation / manual on demand / manual inhibition	
■ DRC-AUTO		Regeneration control of diesel filter particulates - fully automatic (in motion)	
□ 1DAYDIG		One day digital tachograph, EC approved	
■ 1DAYDIG2		Gen 2 one day digital tachograph, EC approved	
□ 1DAYDIGP		One day digital tachograph, EC approved + Prep Kit for TAS-DIG2	
□ ARSL		Additional road speed limiter (switch in dashboard)	
□ SPEED-DU		Dual speed limiter	
□ CRUIS-E		Cruise control I-Cruise with controls in the steering wheel, I-Roll incl. Adding PVT-EXT/MAP give I-See.	
■ CRUISEC		Basic cruise control with controls in steering wheel	
■ ESP-BAS1		Electronic Stability Program package intended for RIGID single vehicles or vehicle combinations with standard centre of gravity height when laden and for TRACTOR vehicle combinations with a single trailer or multiple trailers with ABS/EBS.	
□ ESPC-RO		ESP (Electronic Stability Program) functionality control - Reduced / Off	
□ HWSS-AC		Adaptive cruise control with forward collision warning	
□ HWSS-ACB		Adaptive cruise control with forward collision warning (stationary and moving objects) and emergency braking. Using both radar and camera to collect info.	
■ HWSS-FCB		Forward collision warning (stationary and moving objects) with emergency braking	
■ LSS-DW		Lane keeping support - lane departure warning system	
□ LCS		Lane Change Support	
□ DAS-W		Driver Alert Support (drowsy driver warning)	
□ RSENS-W		Wiper rain sensor	
□ CU-ECC		Fully electrically controlled air conditioning with sun sensor	
□ CU-ECC2		Fully electrically controlled air conditioning with sun sensor, mist sensor, air quality sensor and carbon filter	
■ CU-MCC		Electrical manually controlled air conditioning	
■ IMMOBIL		Immobiliser	
■ Standard Equipment		□ Optional Equipment	

For more detailed information about cab and powertrain equipment, please refer to separate specification sheets.

For all possible options and combinations of options please consult your Volvo sales contact who can create a specification to match your requirements using the Volvo Sales Support system (VSS).

The factory reserves the right to modify design and change equipment without previous notification. The specification can vary from country to country.

MODEL RANGE

FMX D13 64 Rigid rear air FM 64 R3HAX

- ALARM-B** Burglar alarm - cab
 - ALARM-E** Burglar alarm - cab/body/trailer
 - ALCOLOCK** Alcolock
 - BUPMON** Back-up monitor including a 7 inch colour display integrated in dashboard, Waeco CCD-camera (delivered loose in cab) with a heated lens, motorised lens protection, 1 m pigtail cable (front) and 10 metres chassis cable for tractor /20 metres for rigid. Camera wirings not installed. Use PCA30081 for installation.
 - PHONE-PK** Telephone preparation kit (antenna, antenna attachment, cable from antenna to radio shelf).
 - WLIFT-AD** Electrical window lift, auto up/down driver side; el operated on passenger side
 - WLIFT-EB** Electrical window lift. From the driver side both windows can be operated and from the passenger side the passenger side window can be operated.
 - ISUNS-BS** Manually manoeuvred side interior sun visor (roller blind type) on both sides
 - ISUNS-DS** Manually manoeuvred side interior sun visor (roller blind type) on driver side
 - ISUNF-B** Interior front plastic sun visors (driver and passenger side) without mirror on driver side
 - ISUNF-MD** Interior front plastic sun visors (driver and passenger side) with mirror on driver side
 - ISUNF-RE** Electrical textile interior sun visor (roller blind) integrated in front shelf
 - ISUNF-RM** Manual interior textile sun visor (roller-blind) integrated in front shelf
 - ADFS** Two extra DIN slots in front shelf (push/pull storage), 165x40x180 mm (WxHxD)
 - BUPALARM** Back-up alarm
 - RTOLL-PK** Preparation kit for road toll collect (GPS/GSM antenna and cables)
 - LOADIND** Load indicator with dashboard display. Measures axle pressures, load weight and total weight of truck and one trailer.
 - REMC-MF** Wireless remote control - multi functional
 - FIREXT2G** Fire extinguisher 2 kg, German decal
 - FIREXT3S** Fire extinguisher 3 kg, Swedish/English decal
 - WARNVEST** Warning vest. Fulfils European standard according to EN 471 class 2.
 - WARNTRI2** Two warning triangles
 - AIDKIT** First aid kit containing sticking plaster, washing and drying pads, compresses, elastic bandages, respiratory mask, gloves and scissors
 - AIDKIT1B** First aid kit containing sticking plaster, compresses, elastic bandages, gloves, scissors, triangular bandage, bandaging cloths, adhesive tape and rescue sheet (German requirements)
 - WARNLAMP** Portable warning lamp with batteries
 - LAMP-IN** Inspection lamp with 10 m cable
 - BULBKIT** Bulb and fuse kit
 - WRITEPAD** Writing pad with spring-loaded paper clip
- Cab Interior, Living**
- UPHTRI10** Seat upholstery with black embossed textile insert, black vinyl bolster and blue vinyl side insert & textile interior trim in matching grey/blue nuances
 - UPHTRI11** Seat upholstery with light grey embossed textile insert, raven metallic vinyl bolster and red vinyl side insert & vinyl/textile interior trim in matching skylark/grey/black nuances
 - UPHTRI12** Seat upholstery with blue soft textile insert, black vinyl bolster & textile interior trim in matching grey/black/blue colours
 - UPHTRI13** Seat upholstery with dark grey leather insert and black leather bolster & vinyl/textile interior trim in matching grey/black nuances
 - UPHTRI14** Seat with dark grey leather insert and black leather bolster & textile interior trim in matching grey and black colours
 - DST-CF1** Driver seat, comfort, suspended
 - DST-CF4** Driver seat, comfort, suspended, belt in seat
 - DST-CF5** Driver seat, comfort, suspended, belt in seat, electrically heated
 - DST-CF6** Driver seat, comfort, suspended, belt in seat, electrically heated, ventilated
 - SBD-RED** Red safety belts, passenge and driver seats
 - SBPRE-DS** Driver seat belt pretensioner
 - PST-BAS1** Passenger seat, basic, non suspended
 - PST-BENC** Bench passenger seat
 - PST-CF4** Passenger seat, comfort, suspended, belt in seat
 - PST-CF5** Passenger seat, comfort, suspended, belt in seat, electrically heated
 - PST-STD2** Passenger seat, regular, non suspended
 - PST-STD4** Passenger seat, regular, suspended
 - SBPRE-PS** Passenger seat belt pretensioner
 - ARM-DBPS** Two armrests on driver seat and one (outer) on passenger seat
 - ARMRE-BB** Two armrests on both driver and passenger seats
 - ARMRE-DB** Two armrests on driver seat
 - ARMRE-PB** Two armrests on passenger seat
 - ARMRE-PS** Single armrest (next to driver) on passenger seat
 - ARU-BAS** Vinyl armrest upholstery
 - ARU-LEA** Leather armrest upholstery
 - FMAT-RU2** Two black rubber floor mats with raised edges and an extended side (FMX)
 - FMAT-RUB** Two black rubber floor mats
 - FMAT-T2E** Two dark grey textile floor mats and two black rubber floor mats with an extended side (FMX)
 - FMAT-TX2** Two textile (dark grey on FH/FM, black on FH16) and two black rubber floor mats
 - LBK-RES** Lower fixed rest kit, foldable to rear wall
 - LBK70** Lower fixed bunk, not foldable - 2000x700 mm. Safety net included.
 - ULBK** Without lower bunk
 - MATL-FI** Mattress lower bunk - firm for over approx. 100 kg, pocket springs.
 - MATL-SF** Mattress lower bunk - semi-firm up to approx 100 kg, pocket springs.
 - OLMAT-BA** Overlay mattress protector, 28 mm thick black textile
 - OLMAT-PR** Overlay mattress protector, 35 mm thick black textile
 - TBK60F** Fixed top bunk 600x1900 mm, foldable up to 52 degrees to rear wall (depending on cab version and upper storage). Safety net included.
 - TBK70F** Fixed top bunk 700x1900 mm, foldable up to 52 degrees to rear wall (depending on cab version and upper storage). Safety net included.
 - PH-CAB2** Cab parking heater, 2 kW
 - PH-ENGCA** Engine and cab parking heater
 - PH-SS** Short stop heater
 - SLCP-BAS** Basic sleeper control panel (controlling interior light, parking heater, roof hatch and door lock)
 - SAFE** Key operated safe box under bed (FH) or at bed end (FM)
 - ETSB-F** Storage on engine tunnel - on front top
 - ETSB-FR** Storage on engine tunnel - on front top and at rear cab wall
 - ETSB-FRS** Storage on engine tunnel - on front top & at rear cab wall & storage immersed into tunnel on RH side
 - ETSB-FS** Storage on engine tunnel - on front top and storage immersed into tunnel on right hand side
 - ETSB-R** Fixed engine tunnel storage box at rear cab wall
 - ETSB-RS** Storage on engine tunnel - at rear cab wall and storage

■ Standard Equipment

□ Optional Equipment

For more detailed information about cab and powertrain equipment, please refer to separate specification sheets.

For all possible options and combinations of options please consult your Volvo sales contact who can create a specification to match your requirements using the Volvo Sales Support system (VSS).

The factory reserves the right to modify design and change equipment without previous notification. The specification can vary from country to country.

MODEL RANGE

FMX D13 64 Rigid rear air FM 64 R3HAX

- | | |
|--|--|
| <ul style="list-style-type: none"> <input type="checkbox"/> ETSB-S immersed into tunnel on right hand side
Storage on engine tunnel - immersed into tunnel on right hand side <input type="checkbox"/> RUS-BAS Rear cab upper storage 154 litres (300 mm high) <input type="checkbox"/> RUS-HIG Rear cab upper storage 245 litres (440 mm high) <input type="checkbox"/> TABLE Foldable and height adjustable table to be mounted to the lower bunk <input type="checkbox"/> REF-ICPK Refrigerator preparation kit, engine tunnel mounted <input type="checkbox"/> REFR-RUS 28 litre rear upper wall mounted refrigerator with dividers <input type="checkbox"/> MICRO-PK Preparation kit for microwave oven (el. cables to front shelf) <input type="checkbox"/> BOTH-D One 1.5 litre plastic soft-drink bottle holder under dashboard centre section <input type="checkbox"/> COFMA-PK Preparation kit (24V) for coffee maker <input checked="" type="checkbox"/> INLI-BAS Interior white light with smooth light transition at on/off, no dimming <input type="checkbox"/> INLI-NL Interior white and red (night) light with smooth light transition at on/off <input type="checkbox"/> INLI-NLD Interior white and red (night) light with smooth light transition at on/off and dimmer <input type="checkbox"/> ARL-FLEX Two (driver and passenger side) reading lamps with flexible arms (snake lamps) and led lamps fitted on side walls <input type="checkbox"/> RH-EE Without roof hatch, sky window / emergency exit (tinted glass) <input type="checkbox"/> RH-ETR Roof hatch - Electrically operated / Tinted glass / Rear opening <input type="checkbox"/> RH-MSR Roof hatch - Manually operated / Steel / Rear opening <input type="checkbox"/> RH-MTR Roof hatch - Manually operated / Tinted glass / Rear opening <input checked="" type="checkbox"/> URH Without roof hatch <input type="checkbox"/> SWIND-BS Extra side window on both sides <input type="checkbox"/> SWIND-PS Rear side window on passenger side <input type="checkbox"/> VANMIR Vanity mirror in front shelf lid.
In sleeper cab on passenger side and in high/extra high cabs in middle section of the front shelf. <input type="checkbox"/> AS-FUS One extra shelf in each of the two front upper storage compartments.
Only 1 shelf if microwave oven mounted in one of the two compartments. <input type="checkbox"/> INFOT-PK Preparation kit (bracket, security straps, power cable, antenna cable and aux cable) for mounting of a television above driver door. | <ul style="list-style-type: none"> <input type="checkbox"/> RCABS-A Air rear cab suspension <input checked="" type="checkbox"/> RCABS-M Mechanical rear cab suspension <input type="checkbox"/> MIRCOMFX El heated & operated robust main rear view mirrors, electrically heated wide angle mirrors (both sides).
Close view mirror on passenger side. <input checked="" type="checkbox"/> MIRSTDX Electrically heated robust main rear view mirrors and wide angle mirrors (both sides). Close view mirror on passenger side. <input checked="" type="checkbox"/> AMIR-F20 Front close view mirror above windscreen, passenger side (radius 200 mm) <input type="checkbox"/> SUNV-H Exterior transparent dark grey front sun visor <input type="checkbox"/> AD-ROOF Roof air deflector. Design (length, height etc.) automatically calculated and varies depending on vehicle total height (chassis height, cab type, tyres etc). <input type="checkbox"/> AD-SIDEL Long cab side air deflector <input type="checkbox"/> AD-SIDES Short cab side air deflectors <input checked="" type="checkbox"/> HL-BAS2 Halogen H1 head lamps (heavy duty) <input type="checkbox"/> HL-BASIC Halogen H7 head lamps <input type="checkbox"/> HL-BHID2 Bi-Xenon head lamps, high intensity discharged (heavy duty) <input type="checkbox"/> HL-CLEAN High pressure headlamp cleaner <input type="checkbox"/> HLP-ST Steel headlamp protection <input type="checkbox"/> HL-ADJ Adjustable headlamps to adjust the height of the light beam <input checked="" type="checkbox"/> DRL-LED V-shaped ("V-light") day running light (LED).
Turned on low beam gives a dimmed "V-light". <input checked="" type="checkbox"/> UDRIVL Without auxiliary front driving lamps <input type="checkbox"/> ASL-RF2 Two Hella H11 70W spot lamps in sign box (one on each side of the Globetrotter sign) <input type="checkbox"/> ASL-RFPK Preparation kit for two spot lamps in sign box <input type="checkbox"/> BEACOA2F Two front roof mounted amber rotating beacon warning lamps. Mounted on accessory bracket if ordered, otherwise on cab roof on both sides of the hatch. <input type="checkbox"/> BEACOA2R Two rear roof mounted (on accessory bracket) amber warning lamps.
Rotating beacon lamps mounted on sleeper cab.
Flashing LED lamps mounted on high/extra high sleeper cabs. <input type="checkbox"/> BEACON-P Prepared wiring (switch and connected relay included) for warning lamps on cab roof.
Max load 300 W. <input type="checkbox"/> BEACONA4 Four roof mounted amber warning lamps.
2 front mounted (on accessory bracket if ordered) rotating beacon lamps.
2 rear mounted (on mandatory accessory bracket) rotating beacon lamps on sleeper cab.
2 rear mounted (on mandatory accessory bracket) flashing LED lamps on high/xhigh sleeper cabs. <input type="checkbox"/> CABPT-R1 One front cab roof pass through on passenger side <input checked="" type="checkbox"/> CABPT-R2 Two front cab roof pass throughs, one on each side <input type="checkbox"/> SPOTP-F Spotlamp preparation in cab front, max 280W <input type="checkbox"/> SPOTP-R Spotlamp preparation on cab roof, max 280W <input type="checkbox"/> SPOTP-RF Spotlamp preparation on cab roof and in cab front, max 2x280W <input type="checkbox"/> ROS-IL Illuminated roof sign with switch in radio shelf. Switch for turning on/off. <input type="checkbox"/> ROS-IL2 Preparation kit for installing an illuminated roof sign*. It includes a prerouted cable harness, a switch and LED-lamps. The switch is connected in the radio shelf middle section. Switch cap with icon, are enclosed in cab. Lamps in sign are mounted. The stripe in the Globetrotter window is selected via the cab sign variants <input type="checkbox"/> ROS-ILP Wiring preparation kit (wires and switch) for cab sign or roof air deflector illumination <input type="checkbox"/> CSGN-FMX FMX decal in the cab roof sign area <input checked="" type="checkbox"/> HORN-F1S One front mounted (behind grille) single tone air horn, Jericho. Operated by steering wheel buttons. |
|--|--|

Cab Exterior

- PAICS-B** Basic painting in a lightning grey colour of cab surrounding parts (mirror housings, insteps, bumper and if fitted bumper spoiler and sun visor).
If fitted roof air deflector, side air deflector and chassis fairings are always painted in cab colour.
- GLAS-TIN** Tinted windows (front/side/rear)
- AWIND-RF** Rear fixed window (without curtains)
- DGLAS-L** Laminated door glass
- LOCK-MAN** Manual door locking
- LOCK-MRP** Manual door locking with internal remote control (from driver side) of passenger door
- LOCK-REM** Central door locking with remote control
- BUMP-HD** Heavy duty front bumper
- GUARD-EH** Guard plate for cooling pipes and oil sump
- SIDEH-B** Guide rail on day cab driver side
- SIDSTP-R** Side ladder and guide rail on on day cab driver side
- BUGNET** Radiator screen / Mosquito net (PVC coated fibreglass) in front of radiator
- CTILT-P-E** Electrical cab tilt pump
- CTILT-P-M** Manual cab tilt pump
- FCABS-A** Air front cab suspension
- FCABS-M** Mechanical cab suspension

Standard Equipment

Optional Equipment

For more detailed information about cab and powertrain equipment, please refer to separate specification sheets.

For all possible options and combinations of options please consult your Volvo sales contact who can create a specification to match your requirements using the Volvo Sales Support system (VSS).

The factory reserves the right to modify design and change equipment without previous notification. The specification can vary from country to country.

MODEL RANGE

FMX D13 64 Rigid rear air FM 64 R3HAX

- **HORN-R2S** Two roof mounted single tone chromed air horns. Operated by steering wheel buttons.
- **ANT-CBR** Right hand side roof mounted foldable antenna and cables for CB radio, single aerial.
- **ACCBR-AP** Front, middle & rear roof mounted accessory brackets
- **ACCBR-F** Front roof mounted accessory bracket
- **ACCBR-FM** Front & middle roof mounted accessory brackets
- **ACCBR-FR** Front & rear roof mounted accessory brackets
- **ACCBR-M** Middle roof mounted accessory bracket
- **ACCBR-R** Rear roof mounted accessory bracket
- **ACCBR-RM** Rear & middle roof mounted accessory brackets
- **REFS-CW** Reflecting white stripes mounted on cab side
- **REFS-TW** Reflecting white cab side stripes by-packed in cab
- **REFS-TY** Reflecting yellow cab side stripes by-packed in cab
- Superstructure preparations**
 - **BP-MI02** Body Builder preparation package Mixer (02)
 - **BP-TI03** Body Builder preparation package Tipper (03)
 - **CROSSRE** Cross reinforcement for swapbody
 - **SRWL-PK** Wiring preparation for chassis mounted working lamps and a 3-position switch (On/Off/Reverse auto on). Max load 280W.
 - **SWL-2FW** Two H3 70W white front chassis mounted (LH/RH side) working lamps and a 2-position switch (On/Off)
 - **SWL-2RW** Two H3 70W white rear chassis mounted (LH/RH side) working lamps and a 2-position switch (On/Off)
 - **SWL-4W** Four H3 70W white front (2) and rear (2) chassis mounted (LH/RH side) working lamps and a 2-position switch (On/Off)
 - **SWL-PK** Wiring preparation for chassis mounted working lamps and a 2-position switch (On/Off). Max load 280W.
 - **WL-CHPK** Preparation kit (switch and cable) for working lamp, max 2x70 W. Connector on chassis at gearbox.
 - **WLC-H2A** Two H3/70W working lamps with amber coloured lens high mounted back of cab (switch incl).
 - **WLC-H2W** Two H3/70W working lamps, white lens high mounted back of cab (switch incl).
 - **WLC-PKCH** Preparation kit (cables and switch) for cab mounted chassis working lamp. Max load 280W.
 - **WLC-PKH** Preparation kit (cables and switch) for high mounted working lamps back of cab (pass through in cab rear roof included). Max load 280W.
 - **WLC-PKL** Preparation kit (cables and switch) for low mounted working lamps back of cab (pass through in cab rear wall included). Max load 280W.
 - **WLC-PKLH** Preparation kit (cables and switch) for low and high mounted working lamps back of cab (pass throughs in rear wall and rear roof included). Max load 280W.
 - **ECBB-BAS** Body builder electrical centre without any body builder module
 - **ECBB-HIG** Body builder electrical centre with cab body builder module
 - **BBCHAS1** One 7-pole connector for Body builder interface. Wiring harness routed from the bodybuilder electrical distribution box inside the cab to a connection point inside the right frame rail beside the gearbox.
 - **BBCHAS3** Three 7-pole connectors for Body builder interface. Wiring harness routed from the bodybuilder electrical distribution box inside the cab to a connection point inside the right frame rail beside the gearbox.
 - **BEPR-T2** Body builder electrical software preparation for tipper with remote control
 - **EXSTER** Support for external steering control via body builder module
 - **TD-BAS** Trailer detection without LED sensor
 - **TD-LED** Trailer detection with LED sensor
 - **FRFS-BS** Frame rail free space on both sides to give space for crane legs or other equipment.
One front axle with day cab: 515/507 mm (L/R side).
One front axle with long cab: 288/360 mm (L/R side).
Two front axles with short cab: 632/572 mm (L/R side).
Two front axles with long cab: 405/485 mm (L/R side).
- **FBA-BTF** Lower front body attachments for torsionally flexible platform body
- **FBA-BTSF** Lower front body attachments for torsionally semi-flexible body (van or curtainsider)
- **HBA-FSFB** Holes for body attachments, flexible/semi-flexible body
- **HBA-SB** Holes for body attachments, stiff body
- **RBA-T2** Lower rear body attachments for helper frame
- **CRANEPK1** Crane plates mounted to frame, interface for crane capacity up to 10 ton meter
- **CRANEPK2** Crane plates mounted to frame, interface for crane capacity up to 20 ton meter
- **CRANEPK4** Crane plates mounted to frame, interface for crane capacity up to 40 ton meter
- **AUXL-SPK** Electrical preparation kit (wiring and a switch in dashboard) for snow plough lights. Preparation for installation of additional headlights and additional turning indicators.
- **TAILPRE2** Tail lift preparation kit, wireless remote operation
- **TAILPREP** Tail lift preparation kit, wire remote operation
- **AESW2** Two Body builder bistable electrical switches (marked AUX1 / AUX2)
- **AESW2PK** Two Body builder bistable electrical switches (marked AUX1/AUX2) and in an empty 4-group preparation another four bistable switches with dummy switch caps
- **AUXSW-4** Wiring for 4 extra hardwired switches (from Body builder electrical centre to switch positions)
- Services**
 - **TGW-4GWL** Telematics gateway with 4G modem
 - **FMS-PK** Fleet Management System gateway, preparation kit
 - **DRUT** My truck app gives the driver instant status information and control of the vehicle remotely from a smartphone or tablet. The variant enables the My truck app to connect to the vehicle.

VOLVO

Volvo Truck Corporation

volvotrucks.com