

# MODEL RANGE

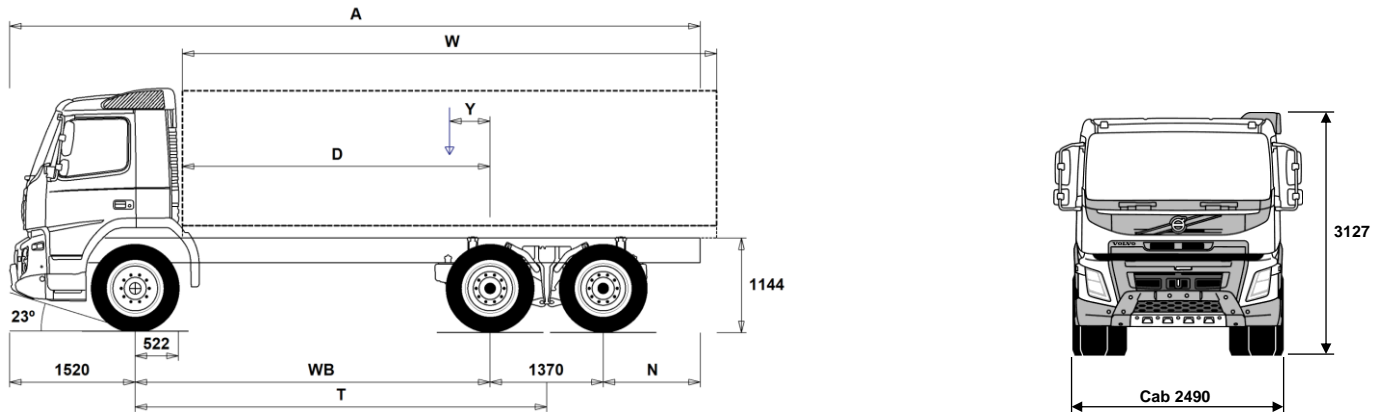

Volvo Trucks. Driving Progress

FMX D13 64 Rigid X-high rear air FM 64 R3CAX



## Chassis Dimensions [mm]

WB Wheelbase	3200	3400	3700	3900	4300	4600
A Overall Chassis Length	7265	7465	7765	7665	8065	8665
D Center of rear axle to front of body	2628	2828	3128	3328	3728	4028
N Rear Overhang (Min.)	825	825	825	825	825	825
N Rear Overhang (Max.)	1175	1175	1175	875	875	1175
T Theoretical Wheelbase	3885	4085	4385	4585	4985	5285
Y Center of Gravity for Payload (Min.)	-32	-1	44	71	130	178
Y Center of Gravity for Payload (Max.)	-32	-1	44	71	130	178
W Body Length (Min.)	5340	5679	6188	6534	7216	7721
W Body Length (Max.)	5340	5679	6188	6534	7216	7721

## Chassis Weights [kg]

Front Axle	4575	4590	4615	4640	4675	4690
Rear Bogie	3725	3730	3740	3710	3735	3785
Kerb Weight	8300	8320	8355	8350	8410	8475
Payload (including body, driver, fuel, etc.)	20700	20680	20645	20650	20590	20525

## Turning Diameter [mm]

Turning Circle Diameter Kerb to Kerb	13900	14500	15500	16100	17300	18200
Turning Circle Diameter Wall to Wall	15400	16000	16900	17500	18800	19700

## Plated Weights [kg]

Gross Vehicle Weight	29000
Gross Combination Weight	44000
Front Axle	8000
Rear Bogie	21000

## Design

## Important Notes

### Chassis Dimensions

Cab Height: +416 mm for CAB-HSLP.  
 Front Axle to Back of Cab: +424 mm for CAB-HSLP and CAB-SLP.  
 D-measure includes a front clearance of 50 mm and for rigid trucks also a subframe of 100 mm.  
 Height can vary  $\pm 20$  mm for leaf and  $\pm 10$  mm for air suspension.  
 All dimensions are for unladen chassis and any tag axles down.  
 Rear overhang used for vehicle weight calculation is the maximum rear overhang (N Max.) for selected wheelbase.

Weight and dimensions are based upon the following tyres:

Front Axle Tyres:	315/80R22.5
Drive Axle Tyres:	315/80R22.5

**Chassis weight includes oil, water, AdBlue, 0 litres fuel and without driver. Kerb weight can vary  $\pm 3\%$ .**

Turning diameters are theoretically calculated.

Legal weights can differ from country to country.

For more detailed weight information, including optional equipment weights, ask your Volvo sales contact to enter your specification into the Volvo Weight Information system (WIS).

Do NOT use this drawing for bodybuilding. Refer to Volvo Bodybuilder Instructions and chassis assembly drawing FM64R3CAX.

# MODEL RANGE

FMX D13 64 Rigid X-high rear air FM 64 R3CAX

## Transport operation

- **RC-ROUGH** Rough road conditions.
  - Less than 95% of the driven distance on well maintained or less maintained surfaced roads.
  - and / or
  - In total not more than 5% of the driven distance on:
    - Very badly maintained surfaced roads.
    - Hard packed sand or gravel surface of very bad quality.
    - Washboards.
    - Soft unpaved surface.
    - Off-road.
- **GARB-PRE** Garbage preparation
- **TIPP-PRE** Tipper vehicle preparation

## Core components

- **CHH-XHIG** Chassis height extra high - approx. 1030 mm above ground level
- **RADD-G2** Rear air suspension, 2 axles - 2 driven, high ground clearance
- **FMX-DAY** FMX Day cab
- **FMX-HSLP** FMX Globetrotter sleeper cab
- **FMX-SLP** FMX Sleeper cab
- **EU6SCR** Euro 6 emission level with Selective Catalytic Reduction (SCR), particulate filter and Exhaust Gas Recirculation (EGR)
- **D13 420S** Diesel engine with Turbo-S, 12.8 litre Euro 6 SCR + EGR (Diesel Particulate Filter), 420 hp, 2100 Nm
- **D13 460S** Diesel engine with Turbo-S, 12.8 litre Euro 6 SCR + EGR (Diesel Particulate Filter), 460 hp, 2300 Nm
- **D13 500S** Diesel engine with Turbo-S, 12.8 litre Euro 6 SCR + EGR (Diesel Particulate Filter), 500 hp, 2500 Nm
- **D13 540S** Diesel engine Turbo-S, 12.8 litre Euro 6 SCR + EGR (Diesel Particulate Filter), 540 hp, 2600 Nm
- **D13K420** Diesel engine, 12.8 litre Euro 6 SCR + EGR (Diesel Particulate Filter), 420 hp
- **D13K460** Diesel engine, 12.8 litre Euro 6 SCR + EGR (Diesel Particulate Filter), 460 hp
- **D13K500** Diesel engine, 12.8 litre Euro 6 SCR + EGR (Diesel Particulate Filter), 500 hp.
- **D13K540** Diesel engine, 12.8 litre Euro 6 SCR + EGR (Diesel Particulate Filter), 540 hp
- **EBR-EPG** Engine brake with exhaust pressure governor, EPG
- **EBR-EPGC** Volvo engine compression brake with exhaust pressure governor, EPG (for I-shift)
- **EBR-VEB+** Volvo Engine Brake, VEB+ (high efficiency compression brake with exhaust pressure governor, EPG)
- **AT2412F** I-Shift automated mechanical 12-speed gearbox without clutch pedal, max. engine torque 2400 Nm, max. permitted GCW 44000 kg.
- **AT2612F** I-Shift automated mechanical 12-speed gearbox without clutch pedal, max. engine torque 2600 Nm, max. permitted GCW 100000 kg.
- **ATO2612F** I-Shift automated mechanical 12-speed overdrive gearbox without clutch, max. engine torque 2600 Nm, max. permitted GCW 100000 kg.  
Suitable for hub reduction rear axles.
- **PT2606** Powertronic automatic 6-speed gearbox, max. engine torque 2600 Nm, max. permitted GCW 130000 kg
- **SPO2812** Semi power shift dual clutch 12-speed overdrive gearbox, max. engine torque 2800 Nm, max permitted GCW 80 000 kg.
- **TAAXLIFT** Tandem axle lift for driven bogie axle
- **RTH2610F** Rear hub reduction tandem axles - bogie load 26 tonnes, GCW 100 tonnes, version F
- **RTS2310A** Rear single reduction tandem axle - bogie load 23 tonnes, GCW100 tonnes
- **RTS2370A** Rear single reduction tandem axles - bogie load 23 tonnes, GCW 70 tonnes

## Packages

- **EDITION** Exterior Striping/Emblem. Model specific design on FH,FM,FH16 and FMX

- Standard Equipment
- Optional Equipment

For more detailed information about cab and powertrain equipment, please refer to separate specification sheets.

For all possible options and combinations of options please consult your Volvo sales contact who can create a specification to match your requirements using the Volvo Sales Support system (VSS).

The factory reserves the right to modify design and change equipment without previous notification. The specification can vary from country to country.

- **DRIVEFM** Driving package FM
- **DRIVEFM+** Driving plus package FM
- **BEDFM** Bed resting package FM
- **AUDBAS** Audio basic. RDS radio with CD player, FM/AM antenna and speakers in dashboard & doors.  
Prepared for Dynafleet office internet portal support.
- **AUDHIG** High power audio system. RDS radio with CD player (also playing mp3/wma/wav files from CD), FM/AM antenna, speakers in dashboard & doors & sleeping compartment, integrated bluetooth phone and USB/Line inputs.  
Prepared for Dynafleet office internet portal support.
- **MEDIA** Media package with infotainment. Prepared for Dynafleet office internet portal support.
- **MEDIADF** Media package with infotainment. Prepared for both Dynafleet vehicle onboard support and for Dynafleet office internet portal support.
- **MEDIANAV** Media package with infotainment and Navigation support and prepared for Dynafleet office internet portal support.
- **MEDIANDF** Media package with infotainment and Navigation support and prepared for Dynafleet vehicle onboard support and for Dynafleet office internet portal support.

- **VISIX15** Visibility package FMX
- **ENOPT** Energy optimization package
- **ENOPT+** Energy optimization+ package
- **OFFRFMXD** Construction package for FMX day cab
- **OFFRFMXS** Construction package for FMX sleeper cabs

## Chassis

- **FST-PAR3** 3 leaf front parabolic suspension (stiffer than normal)
- **FSLB-BAS** Front air suspension basic levelling stroke
- **FSLB-HI** Front air suspension high levelling stroke
- **FAL10.0** Front axle load 10.0 tonnes
- **FAL8.0** Front axle load 8.0 tonnes
- **FAL9.0** Front axle load 9.0 tonnes
- **FALIM** Front axle load limiter
- **FSTAB** Front stabilizer with normal stiffness
- **FSTAB2** Front stabilizer with medium high stiffness
- **FSTAB3** Front stiff stabilizer
- **RAL21** Rear axles load 21 tonnes
- **RAL23** Rear axles load 23 tonnes
- **RAL26** Rear axles load 26 tonnes
- **RSTAB3** Rear stiff stabilizer
- **RALIM105** First rear drive axle load limiter, 10.5 tonnes (speed controlled)
- **RALIM115** First rear drive axle load limiter, 11.5 tonnes (speed controlled)
- **RALIM13** First rear drive axle load limiter, 13 tonnes
- **RALIM95** First rear drive axle load limiter, 9.5 tonnes
- **ASF-DL1** Air suspension with 1 driving level
- **ASF-DL3** Air suspension with 3 driving levels
- **ACTST-TO** Volvo Dynamic Steering (VDS) with extra pump and torque overlay
- **ASFE-BAS** Volvo Dynamic Steering feature basic
- **ASFE-PS** Volvo Dynamic Steering personal settings
- **PSS-SING** Single power steering system
- **PSP-FIX** Power steering pump with fixed displacement
- **PSP-VAR** Power steering pump with variable displacement
- **EBS-MED** EBS (Electronic Brake System) medium package:
  - ABS (Anti-lock Braking System)
  - Lining Wear Sensing (20 % left)
  - Lining Wear Control (incl. wear on the axle)
  - Brake Blending
  - Drag Torque Control
  - Diff Lock Synchronization
  - Diff lock Control
  - Brake Temperature Warning
  - External Brake Demand

# MODEL RANGE

FMX D13 64 Rigid X-high rear air FM 64 R3CAX

	- Diagnosis Via Truck Electronic System - Traction Control System - Emergency Brake Assistance - Constant Wheel Brake Monitoring - Coupling Force Control - Automatic Parking Brake Activation - Lining Wear Analyses (calc of remaining mileage) - Hill Starting Assistance - EBS status monitoring via Truck Electronic System	reduced distance (moved inwards) to silencer. Makes better space for e.g. support legs.
<input type="checkbox"/> <b>AUXPARK</b>	Two extra parking brake chambers	<input type="checkbox"/> <b>WHC-FIX2</b> <input checked="" type="checkbox"/> <b>WHC-FOL2</b>
<input checked="" type="checkbox"/> <b>FBREG-E</b>	Front axle regulating brake valve for EBS	Two fixed wheel chocks 2 foldable wheel chocks
<input checked="" type="checkbox"/> <b>SUSPL-EC</b>	Air suspension levelling with electronic control	<input type="checkbox"/> <b>WHCP-F</b>
<input type="checkbox"/> <b>FRAME266</b> <input checked="" type="checkbox"/> <b>FRAME300</b>	Frame rail section external height 266 mm Frame rail section external height 300 mm	Wheel chock(s) in the front part of the vehicle. - TRACTOR, BBOX-L, Fold, 1/2 w chocks = Top of left side battery box - TRACTOR, BBOX-EF, Fold, 1/2 w chocks = Top of lefts side fuel tank - TRACTOR, BBOX-EF, Fix, 2 w chocks = Left frame front of fuel tank - RIGID, 1 front axle, Fold, 1/2 w chocks = Top of left side battery box - RIGID, 2 front axles, Fold, Frame free space, 2 wc = Top of left side battery box - RIGID, 2 front axles, Fix, W/o frame free space, 2 wc = Left frame behind 1st front wheel
<input type="checkbox"/> <b>FST7070</b> <input checked="" type="checkbox"/> <b>FST8080</b>	Frame section thickness - web 7.0 mm / flange 7.0 mm Frame section thickness - web 8.0 mm / flange 8.0 mm	<input type="checkbox"/> <b>WHCP-M</b>
<input type="checkbox"/> <b>FIL-EEEB</b> <input type="checkbox"/> <b>FIL-EEEF</b> <input type="checkbox"/> <b>FIL-FBEB</b> <input type="checkbox"/> <b>FIL-FBEF</b> <input checked="" type="checkbox"/> <b>FIL-TXEB</b>	Frame inner liner from end of engine end to end of bogie Frame inner liner from end of engine end to end of frame Frame inner liner from front of bogie to end of bogie Frame inner liner from front of bogie to end of frame Frame inner liner from transmission cross member to end of bogie	Wheel chock(s) in the middle part of the vehicle - TRACTOR, BBOX-L, Fix, 1/2 w chocks = Left frame front of rear wheels - RIGID, 1 front axle, Fix, 1/2 w chocks = Left frame front of (or behind) rear wheels
<input type="checkbox"/> <b>FIL-TXEF</b>	Frame inner liner from transmission cross member to end of frame	<input type="checkbox"/> <b>WHCP-R</b>
<input checked="" type="checkbox"/> <b>BBOX-L</b>	Battery box on left hand side	Wheel chock(s) in the rear part of the vehicle - RIGID, 1 front axle, Fix, 1/2 w chocks = Left frame rear (or front) of rear wheels
<input type="checkbox"/> <b>2BAT210B</b> <input type="checkbox"/> <b>2BATT170</b> <input type="checkbox"/> <b>2BATT225</b>	Gel batteries 2x210 Ah Batteries 2x170 Ah Batteries 2x225 Ah	<input type="checkbox"/> <b>WHCP-T</b>
<input checked="" type="checkbox"/> <b>BATTAMP</b> <input type="checkbox"/> <b>BATTIND</b>	Battery voltage and ampere gauge Battery voltage, ampere and battery status gauge with visual alerts	<input type="checkbox"/> <b>TB-L80</b>
<input type="checkbox"/> <b>ADR2</b>	ADR adaptation - transportation of dangerous goods, 2 switches (1 inside cab in dashboard, 1 outside on cab back passenger side).	<input type="checkbox"/> <b>TB-R80</b>
<input type="checkbox"/> <b>MSWI-A</b> <input checked="" type="checkbox"/> <b>MSWI-C</b>	ADR main switch - ADR switch circuit shut down Chassis main switch - battery box placed toggle switch circuit shut down	<input type="checkbox"/> <b>CHAIN-S</b>
<input type="checkbox"/> <b>MSWI-R</b>	Remote controlled main switch - key fob operated circuit shut down	<input type="checkbox"/> <b>HOOK-SC</b>
<input checked="" type="checkbox"/> <b>R315A56</b>	Right 315 litre aluminium 560 mm high D-shaped diesel tank. Usable volume is 97% of stated volume. Min volume 255l Max volume 885l	Snow chains Snow chain hooks. Rear mounted for tractors and side mounted in rear overhang for rigids. Two hooks on each side.
<input checked="" type="checkbox"/> <b>UL-FUEL</b>	Without left diesel tank Min volume 160l Max volume 730l	<input checked="" type="checkbox"/> <b>TOWF-HD1</b>
<input type="checkbox"/> <b>ADTP-L</b> <input checked="" type="checkbox"/> <b>ADTP-R</b>	AdBlue tank on left hand side (for dual front axles between the axles) AdBlue tank on right hand side	<input type="checkbox"/> <b>TOWMBRH</b> <input type="checkbox"/> <b>TOWMBRL1</b> <input type="checkbox"/> <b>TOWMBRM</b>
<input checked="" type="checkbox"/> <b>ADB048</b> <input checked="" type="checkbox"/> <b>ADB064</b> <input type="checkbox"/> <b>ADB068</b> <input type="checkbox"/> <b>ADB090</b> <input type="checkbox"/> <b>ADB100</b>	AdBlue tank usable volume 48 litres AdBlue tank usable volume 64 litres AdBlue tank usable volume 68 litres AdBlue tank usable volume 90 litres AdBlue tank usable volume 100 litres	High mounted towing member, in centre of frame Towing member, low mounted under the frame (position 1) Towing member, medium mounted in line with frame lower flange
<input checked="" type="checkbox"/> <b>FCAP-L</b>	Lockable diesel and AdBlue tank caps	<input type="checkbox"/> <b>RFEC-L</b> <input checked="" type="checkbox"/> <b>RFEC-S</b> <input type="checkbox"/> <b>RFEC-U</b>
<input checked="" type="checkbox"/> <b>FUFF-AS</b> <input type="checkbox"/> <b>FUFF-ATS</b>	Fuel filling anti-spillage device Fuel filling anti-theft and anti-spillage devices	Rear frame end, lower cut (for centre axle drawbar) Rear frame end, straight cut (for regular platform applications) Rear frame end, upper cut (for e.g. tipper, refuse and hooklift applications)
<input type="checkbox"/> <b>ESH-LEFT</b> <input checked="" type="checkbox"/> <b>ESH-REAR</b> <input type="checkbox"/> <b>ESH-VERT</b> <input type="checkbox"/> <b>ESV-VERT</b>	Horizontal muffler, left exhaust outlet Horizontal muffler, rear exhaust outlet Horizontal muffler, vertical exhaust outlet on right hand side Vertical muffler, vertical exhaust outlet on right hand side	<input type="checkbox"/> <b>C-RI4040</b> <input type="checkbox"/> <b>C-RI4045</b> <input type="checkbox"/> <b>C-RI5055</b> <input type="checkbox"/> <b>C-RO400G</b> <input type="checkbox"/> <b>C-RO50</b> <input type="checkbox"/> <b>C-VBG750</b> <input type="checkbox"/> <b>C-VBG850</b>
<input type="checkbox"/> <b>EXST-SSP</b> <input type="checkbox"/> <b>EXST-ST</b>	Bright polished vertical stainless steel exhaust top pipe Aluminized steel vertical exhaust top pipe	Towing coupling Ringfeder RF4040A G-150 Towing coupling Ringfeder RF4045A G-150 Towing coupling Ringfeder RF5055A G-150 Towing coupling Rockinger 400 G-150 Towing coupling Rockinger 50 mm Towing coupling VBG 750V Towing coupling VBG 8500
<input type="checkbox"/> <b>HS-NAR</b>	Narrow Euro 6 muffler heat shield. Partly (due to heat release)	<input type="checkbox"/> <b>TOWR-ONE</b>
<input checked="" type="checkbox"/> <b>Standard Equipment</b>	<input type="checkbox"/> <b>Optional Equipment</b>	<input checked="" type="checkbox"/> <b>TREL-PK</b> <input type="checkbox"/> <b>TREL15</b> <input type="checkbox"/> <b>TREL7-7</b>
		Trailer electrical preparation kit (chassis/cab wiring) 15 pol electrical trailer connector (ADR certified) 2x7 pol (24N+24S) electrical trailer connectors (UADR)
		<input type="checkbox"/> <b>TBC-DUO</b> <input type="checkbox"/> <b>TBC-EC</b>
		Trailer brake connection, Duomatic Trailer brake connection, European Community
		<input type="checkbox"/> <b>TRBR-STA</b>
		Stationary trailer brake control
		<input type="checkbox"/> <b>TRB-STRE</b>
		Automatic low speed trailer brake activation (stretch brake) to avoid jack-knifing and to improve steerability
		<input type="checkbox"/> <b>RUP-FOSL</b>
		Foldable and slidable aluminium rear underrun protection, EC approved
		<input type="checkbox"/> <b>RFEND-B</b> <input type="checkbox"/> <b>RFEND-T</b>
		Rear 3 piece fenders with anti-spray function (all rear axles) Transport mounted one-piece rear fenders
		<input type="checkbox"/> <b>RFH-BAS</b>
		Optimal fender installation (rear and 2nd front axle) with regard

For more detailed information about cab and powertrain equipment, please refer to separate specification sheets.

For all possible options and combinations of options please consult your Volvo sales contact who can create a specification to match your requirements using the Volvo Sales Support system (VSS).

The factory reserves the right to modify design and change equipment without previous notification. The specification can vary from country to country.

# MODEL RANGE

FMX D13 64 Rigid X-high rear air FM 64 R3CAX

- to legal demands, wheel/tyre sizes, chassis height and fifth wheel height.
- **RFH-HIG** Highest fender installation (rear and 2nd front axle). Suitable for rough and very rough road conditions.
- **RFH-LOW** Lower fender installation (rear and 2nd front axle). Suitable only for smooth road conditions. Increased risk of fender top wear.
- **AUXATNK** Extra air tank
- **ATANK-AL** Aluminium air tanks
- **ATANK-ST** Steel air tanks
- **RESTS-W** Reflecting white stripes mounted on chassis side (underrun prot./toolbox/between fenders/overhang)
- **REST-RUP** Reflecting red stripes mounted on rear underrun protection
- **TL-LED** LED tail lamps (tail light, exterior marker light, brake light, hazard warning light, reverse light, rear fog light, licence plate light and reflector).
- **BLIGHT-E** Emergency brake light
- **FRACLOS** Frame end closing

## Rims and Tyres

- **RT-AL** Brushed aluminium rims with std holes (long stud fixing) on all axles
- **RT-ALDP** Dura-Bright polished aluminium rims with std holes (long stud fixing) on all axles
- **RT-ALDPD** Dura-Bright polished aluminium rims with countersunk holes (short stud fixing) on all axles
- **RT-ALDU** Brushed aluminium rims with countersunk holes (short stud fixing) on all axles
- **RT-SPOKE** Spoke rims on all axles
- **RT-STEEL** Steel rims on all axles
- **WCAP** Wheel caps
- **BRREC001** Bridgestone ECOPIA H - Fuel Tyre Recommendation 1
- **BRREC002** Bridgestone Ecopia H 002 Evo - Tyre recommendation 2
- **COREC002** Continental ECOPLUS HS3/HD3 - Fuel Tyre Recommendation 2
- **GYREC001** Good Year Fuelmax S/ HL/ D Tire Recommendation 2
- **GYREC002** Good Year Fuelmax S Gen-2 Long Haul - Tyre Recommendation 2
- **GYREC003** Good Year Fuelmax S/(O)/D - Tyre Recommendation 3
- **HAREC001** Hankook AL10+ E-Cube Max Long Haul Tire Recommendation 1
- **HAREC002** Hankook AL10+ E-Cube Long Haul Tire Recommendation 2
- **MIREC002** Michelin XZA2/X-LINE Energy - Fuel Tyre Recommendation 2
- **MIREC003** Michelin X-LINE Energy - Fuel Tyre Recommendation 3
- **MIREC004** FUEL EFFICIENCY CLASS A Michelin X Line Energy F/D2 - Fuel Tyre Recommendation 4
- **PIREC001** Pirelli FH:01 Proway - Tyre Recommendation 1
- **PIREC002** Pirelli FH:01 II - Tyre Recommendation 2
- **SPWT-D** Spare wheel with tyre equal to drive
- **SPWT-F** Spare wheel with tyre equal to front wheel
- **SWCP-LF** Spare wheel carrier on left side in front of rear axle
- **SWCP-R** Spare wheel carrier mounted behind rear axle and below frame
- **SWCP-T** Temporary spare wheel carrier. Spare wheel is transport mounted (strapped on top of the frame rails) with plastic stripes.
- **SWCP-TP** Spare wheel carrier transport mounted with the spare wheel on top of the frame rails
- **JACK-12T** Jack 12 tonnes
- **JACK-15T** Jack 15 tonnes
- **JACK-20T** Jack 20 tonnes
- **TOOL-BAS** Basic tools (combination screw driver, socket wrench)
- **TOOLKIT** Extended tool kit
- **INFLAHO** Tyre inflation hose (18 metres) with nozzles in both ends
- **GAUGE-TP** Tyre pressure gauge
- **OBDEP-C** EU6 mandatory on board diagnostics, phase C regulations
- **OBDEP-D** EU6 mandatory on board diagnostics, phase D regulations

■ Standard Equipment

□ Optional Equipment

For more detailed information about cab and powertrain equipment, please refer to separate specification sheets.

For all possible options and combinations of options please consult your Volvo sales contact who can create a specification to match your requirements using the Volvo Sales Support system (VSS).

The factory reserves the right to modify design and change equipment without previous notification. The specification can vary from country to country.

## Powertrain equipment

- **ASO-C** One crawler gear
- **ASO-ULC** Two crawler gears, one ultra low crawler and one crawler
- **TRAP-HD** Reinforced gearbox application. For manual gearboxes a heavy-duty nodular iron range housing. For I-shift gearboxes (2412 excl.) a reinforced gear shifting system.
- **PVT-BAS** Basic topography information, learning by GPS positioning
- **PVT-EXT** Extended topography information, learning by GPS positioning and centrally stored data
- **TP-BAS** I-shift City gear changing software
- **TP-CON** I-shift construction gear changing software
- **TP-DIST** I-shift distribution gear changing software
- **TP-HD** I-shift Heavy Duty gear changing software
- **TP-LONG** I-shift long haul gear changing software
- **AMSO-AUT** I-shift manual gear shift available in automatic mode incl kickdown function
- **AVO-ENH** Enhanced I-shift software for construction and off road applications
- **APF-ENH** Enhanced I-shift PTO functions (Auto Neutral / Reverse Inhibit / Split Box Connection)
- **RET-TH** Retarder (incl cooler) for manual and I-shift gearboxes with oil as brake fluid
- **RET-TPT** Retarder for hydraulic gearbox
- **TC-HWO** Cooler for hydraulic gearboxes - water/oil
- **TC-MAOH2** Extra high performance cooler for manual/I-shift gearboxes - air/oil
- **TC-MWO** Basic performance cooler for manual/I-Shift gearboxes - water/oil
- **TC-MWOH2** High performance cooler for manual/I-Shift gearboxes - water/oil
- **2COM1100** Dual cylinder air compressor 760 cc / 1100 l/min
- **2COMP900** Dual cylinder air compressor 636 cc
- **CLU-AIRC** Air compressor clutch automatically declutched when not needed in order to save fuel
- **AIRIN-HI** High air intake
- **AIRIN-LO** Low air intake
- **ACL1ST-S** Air cleaner with additional filter element (primary + secondary)
- **24AL110B** Alternator 110 Ampere
- **24AL120B** Alternator 120 Ampere
- **24AL150B** Alternator 150 Ampere
- **CCV-C** Closed crankcase ventilation
- **PRIM-EL** Electrical priming pump for fast and easy bleeding of the fuel system
- **PRIM-MAN** Manual priming pump for fast and easy bleeding of the fuel system
- **AF-R** Hot fuel recirculation heated fuel filter
- **EST-AID** Engine start pre-heating element
- **220EBH15** Engine block heater, 220 volt, 1.5 kW
- **PTER-100** Rear engine mounted clutch independent power-take-off with flange connection (DIN 100 / ISO 7646)
- **PTER-DIN** Rear engine mounted clutch independent PTO with splined shaft groove (female) for a close coupled pump (DIN 5462 / ISO 7653)
- **PTER1400** Rear engine mounted clutch independent power-take-off with flange connection (SAE 1410 / ISO 7647)
- **HPE-F101** Rear engine mounted hydraulic pump F1-101, fixed displacement, single flow
- **HPE-F41** Rear engine mounted hydraulic pump F1-41, fixed displacement, single flow
- **HPE-F51** Rear engine mounted hydraulic pump F1-51, fixed displacement, single flow

# MODEL RANGE

## FMX D13 64 Rigid X-high rear air FM 64 R3CAX

- HPE-F61** Rear engine mounted hydraulic pump F1-61, fixed displacement, single flow
- HPE-F81** Rear engine mounted hydraulic pump F1-81, fixed displacement, single flow
- HPE-T53** Rear engine mounted hydraulic pump F2-53/53, fixed displacement, twin flow
- HPE-T70** Rear engine mounted hydraulic pump F2-70/35, fixed displacement, twin flow
- HPE-V45** Rear engine mounted hydraulic pump VP1-45, variable displacement, single flow
- HPE-V75** Rear engine mounted hydraulic pump VP1-75, variable displacement, single flow
- PTPT-D** Automatic gearbox driven power take-off, 1 front/upper connection (DIN 5462 / ISO 7653) for plug-in pump (max. 850 Nm).
- PTPT-F** Automatic gearbox driven Power take-off, 1 front/upper rear facing flange connection (SAE 1410 / ISO 7647) for propeller shaft (max. 850 Nm).
- PTR-D** Mechanical gearbox driven low speed power take-off, 1 rear connection (DIN 5462 / ISO 7653) for plug-in pump (max. 1000 Nm).
- PTR-DH** Mechanical gearbox driven high speed power take-off, 1 rear connection (DIN 5462 / ISO 7653) for plug-in pump (max. 600 Nm).
- PTR-DM** Mechanical gearbox driven medium speed power take-off, 1 rear connection (DIN 5462 / ISO 7653) for plug-in pump (max. 600 Nm).
- PTR-F** Mechanical gearbox driven low speed power take-off, 1 rear flange connection (SAE 1410 / ISO 7647) for propeller shaft (max. 1000 Nm).
- PTR-FH** Mechanical gearbox driven high speed power take-off, 1 rear flange connection (SAE 1310 / ISO 7647) for propeller shaft (max. 600 Nm).
- PTR-FL** Mechanical gearbox driven low speed power take-off, 1 rear flange connection (SAE 1310 / ISO 7647) for propeller shaft (max. 600 Nm).
- PTRD-D** Mechanical gearbox driven high speed power take-off, 1 rear and 1 front connections (DIN 5462 / ISO 7653) for plug-in pumps (max. 870 Nm).
- PTRD-D1** Mechanical gearbox driven high speed power take-off, 1 rear flange connection (SAE 1410 / ISO 7647) for propeller shaft / 1 front connection (DIN 5462 / ISO 7653) for plug-in pump (max. 870 Nm).
- PTRD-D2** Mechanical gearbox driven power take-off, 2 rear flange (high-low speed) connections (SAE 1310/1410 / ISO 7647) for propeller shafts / 1 front (high speed) connection (DIN 5462 / ISO 7653) for plug-in pump (max. 870/1000 Nm).
- PTRD-F** Mechanical gearbox driven high speed power take-off, 1 rear flange connection (SAE 1410 / ISO 7647) for propeller shaft (max. 870 Nm).
- HPG-F101** Gearbox mounted hydraulic pump F1-101, fixed displacement, single flow
- HPG-F41** Gearbox mounted hydraulic pump F1-41, fixed displacement, single flow
- HPG-F51** Gearbox mounted hydraulic pump F1-51, fixed displacement, single flow
- HPG-F61** Gearbox mounted hydraulic pump F1-61, fixed displacement, single flow
- HPG-F81** Gearbox mounted hydraulic pump F1-81, fixed displacement, single flow
- EIDLESD** Engine idle shut down
- HPE-F61** Rear engine mounted hydraulic pump F1-61, fixed displacement, single flow
- HPE-F81** Rear engine mounted hydraulic pump F1-81, fixed displacement, single flow
- HPE-T53** Rear engine mounted hydraulic pump F2-53/53, fixed displacement, twin flow
- HPE-T70** Rear engine mounted hydraulic pump F2-70/35, fixed displacement, twin flow
- HPE-V45** Rear engine mounted hydraulic pump VP1-45, variable displacement, single flow
- HPE-V75** Rear engine mounted hydraulic pump VP1-75, variable displacement, single flow
- PTPT-D** Automatic gearbox driven power take-off, 1 front/upper connection (DIN 5462 / ISO 7653) for plug-in pump (max. 850 Nm).
- PTPT-F** Automatic gearbox driven Power take-off, 1 front/upper rear facing flange connection (SAE 1410 / ISO 7647) for propeller shaft (max. 850 Nm).
- PTR-D** Mechanical gearbox driven low speed power take-off, 1 rear connection (DIN 5462 / ISO 7653) for plug-in pump (max. 1000 Nm).
- PTR-DH** Mechanical gearbox driven high speed power take-off, 1 rear connection (DIN 5462 / ISO 7653) for plug-in pump (max. 600 Nm).
- PTR-DM** Mechanical gearbox driven medium speed power take-off, 1 rear connection (DIN 5462 / ISO 7653) for plug-in pump (max. 600 Nm).
- PTR-F** Mechanical gearbox driven low speed power take-off, 1 rear flange connection (SAE 1410 / ISO 7647) for propeller shaft (max. 1000 Nm).
- PTR-FH** Mechanical gearbox driven high speed power take-off, 1 rear flange connection (SAE 1310 / ISO 7647) for propeller shaft (max. 600 Nm).
- PTR-FL** Mechanical gearbox driven low speed power take-off, 1 rear flange connection (SAE 1310 / ISO 7647) for propeller shaft (max. 600 Nm).
- PTRD-D** Mechanical gearbox driven high speed power take-off, 1 rear and 1 front connections (DIN 5462 / ISO 7653) for plug-in pumps (max. 870 Nm).
- PTRD-D1** Mechanical gearbox driven high speed power take-off, 1 rear flange connection (SAE 1410 / ISO 7647) for propeller shaft / 1 front connection (DIN 5462 / ISO 7653) for plug-in pump (max. 870 Nm).
- PTRD-D2** Mechanical gearbox driven power take-off, 2 rear flange (high-low speed) connections (SAE 1310/1410 / ISO 7647) for propeller shafts / 1 front (high speed) connection (DIN 5462 / ISO 7653) for plug-in pump (max. 870/1000 Nm).
- PTRD-F** Mechanical gearbox driven high speed power take-off, 1 rear flange connection (SAE 1410 / ISO 7647) for propeller shaft (max. 870 Nm).
- HPG-F101** Gearbox mounted hydraulic pump F1-101, fixed displacement, single flow
- HPG-F41** Gearbox mounted hydraulic pump F1-41, fixed displacement, single flow
- HPG-F51** Gearbox mounted hydraulic pump F1-51, fixed displacement, single flow
- HPG-F61** Gearbox mounted hydraulic pump F1-61, fixed displacement, single flow
- HPG-F81** Gearbox mounted hydraulic pump F1-81, fixed displacement, single flow
- EIDLESD** Engine idle shut down
- ALCOLOCK** Alcolock
- BUPMON** Back-up monitor including a 7 inch colour display integrated in dashboard, Waeco CCD-camera (delivered loose in cab) with a heated lens, motorised lens protection, 1 m pigtail cable (front) and 10 metres chassis cable for tractor /20 metres for rigid. Camera wirings not installed. Use PCA30081 for installation.
- PHONE-PK** Telephone preparation kit (antenna, antenna attachment, cable from antenna to radio shelf).
- WLIFT-AD** Electrical window lift, auto up/down driver side; el operated on passenger side
- WLIFT-EB** Electrical window lift. From the driver side both windows can be operated and from the passenger side the passenger side window can be operated.
- ISUNS-BS** Manually manoeuvred side interior sun visor (roller blind type) on both sides
- ISUNS-DS** Manually manoeuvred side interior sun visor (roller blind type) on driver side
- ISUNF-B** Interior front plastic sun visors (driver and passenger side) without mirror on driver side
- ISUNF-MD** Interior front plastic sun visors (driver and passenger side) with mirror on driver side
- ISUNF-RE** Electrical textile interior sun visor (roller blind) integrated in front shelf
- ISUNF-RM** Manual interior textile sun visor (roller-blind) integrated in front shelf
- ADFS** Two extra DIN slots in front shelf (push/pull storage), / manual on demand / manual inhibition
- DRC-AUTO** Regeneration control of diesel filter particulates - fully automatic (in motion)
- 1DAYDIG2** Gen 2 one day digital tachograph, EC approved
- 1DAYDIGP** One day digital tachograph, EC approved + Prep Kit for TAS-DIG2
- ARSL** Additional road speed limiter (switch in dashboard)
- SPEED-DU** Dual speed limiter
- CRUISE-E** Cruise control I-Cruise with controls in the steering wheel, I-Roll incl. Adding PVT-EXT/-MAP give I-See.
- CRUISEC** Basic cruise control with controls in steering wheel
- ESP-BAS1** Electronic Stability Program package intended for RIGID single vehicles or vehicle combinations with standard centre of gravity height when laden and for TRACTOR vehicle combinations with a single trailer or multiple trailers with ABS/EBS.
- ESPC-RO** ESP (Electronic Stability Program) functionality control - Reduced / Off
- HWSS-AC** Adaptive cruise control with forward collision warning
- HWSS-ACB** Adaptive cruise control with forward collision warning (stationary and moving objects) and emergency braking. Using both radar and camera to collect info.
- HWSS-FCB** Forward collision warning (stationary and moving objects) with emergency braking
- LSS-DW** Lane keeping support - lane departure warning system
- LCS** Lane Change Support
- DAS-W** Driver Alert Support (drowsy driver warning)
- RSENS-W** Wiper rain sensor
- CU-ECC** Fully electrically controlled air conditioning with sun sensor
- CU-ECC2** Fully electrically controlled air conditioning with sun sensor, mist sensor, air quality sensor and carbon filter
- CU-MCC** Electrical manually controlled air conditioning
- IMMOBIL** Immobiliser
- ALARM-B** Burglar alarm - cab
- ALARM-E** Burglar alarm - cab/body/trailer

### ■ Standard Equipment

### □ Optional Equipment

For more detailed information about cab and powertrain equipment, please refer to separate specification sheets.

For all possible options and combinations of options please consult your Volvo sales contact who can create a specification to match your requirements using the Volvo Sales Support system (VSS).

The factory reserves the right to modify design and change equipment without previous notification. The specification can vary from country to country.

# MODEL RANGE

FMX D13 64 Rigid X-high rear air FM 64 R3CAX

	165x40x180 mm (WxHxD)		
<input type="checkbox"/>	<b>BUPALARM</b>	Back-up alarm	<input type="checkbox"/> <b>FMAT-RUB</b>
<input type="checkbox"/>	<b>RTOLL-PK</b>	Preparation kit for road toll collect (GPS/GSM antenna and cables)	<input type="checkbox"/> <b>FMAT-T2E</b>
<input type="checkbox"/>	<b>LOADIND</b>	Load indicator with dashboard display. Measures axle pressures, load weight and total weight of truck and one trailer.	<input type="checkbox"/> <b>FMAT-TX2</b>
<input type="checkbox"/>	<b>REMC-MF</b>	Wireless remote control - multi functional	<input type="checkbox"/> <b>LBK-RES</b>
<input type="checkbox"/>	<b>FIREXT2G</b>	Fire extinguisher 2 kg, German decal	<input type="checkbox"/> <b>LBK70</b>
<input type="checkbox"/>	<b>FIREXT3S</b>	Fire extinguisher 3 kg, Swedish/English decal	<input checked="" type="checkbox"/> <b>ULBK</b>
<input type="checkbox"/>	<b>WARNVEST</b>	Warning vest. Fulfils European standard according to EN 471 class 2.	<input type="checkbox"/> <b>MATL-FI</b>
<input checked="" type="checkbox"/>	<b>WARNTRI2</b>	Two warning triangles	<input type="checkbox"/> <b>MATL-SF</b>
<input checked="" type="checkbox"/>	<b>AIDKIT</b>	First aid kit containing sticking plaster, washing and drying pads, compresses, elastic bandages, respiratory mask, gloves and scissors	<input type="checkbox"/> <b>OLMAT-BA</b>
<input type="checkbox"/>	<b>AIDKIT1B</b>	First aid kit containing sticking plaster, compresses, elastic bandages, gloves, scissors, triangular bandage, bandaging cloths, adhesive tape and rescue sheet (German requirements)	<input type="checkbox"/> <b>OLMAT-PR</b>
<input type="checkbox"/>	<b>WARNLAMP</b>	Portable warning lamp with batteries	<input type="checkbox"/> <b>TBK60F</b>
<input type="checkbox"/>	<b>LAMP-IN</b>	Inspection lamp with 10 m cable	<input type="checkbox"/> <b>TBK70F</b>
<input type="checkbox"/>	<b>BULBKIT</b>	Bulb and fuse kit	<input type="checkbox"/> <b>PH-CAB2</b>
<input type="checkbox"/>	<b>WRITEPAD</b>	Writing pad with spring-loaded paper clip	<input type="checkbox"/> <b>PH-ENGCA</b>
			<input type="checkbox"/> <b>PH-SS</b>
			<input type="checkbox"/> <b>SLCP-BAS</b>
			<input type="checkbox"/> <b>SAFE</b>
			<input type="checkbox"/> <b>ETSB-F</b>
			<input type="checkbox"/> <b>ETSB-FR</b>
			<input type="checkbox"/> <b>ETSB-FRS</b>
			<input type="checkbox"/> <b>ETSB-FS</b>
			<input type="checkbox"/> <b>ETSB-R</b>
			<input type="checkbox"/> <b>ETSB-RS</b>
			<input type="checkbox"/> <b>ETSB-S</b>
			<input type="checkbox"/> <b>RUS-BAS</b>
			<input type="checkbox"/> <b>RUS-HIG</b>
			<input type="checkbox"/> <b>TABLE</b>
			<input type="checkbox"/> <b>REF-ICPK</b>
			<input type="checkbox"/> <b>REFR-RUS</b>
			<input type="checkbox"/> <b>MICRO-PK</b>
			<input type="checkbox"/> <b>BOTH-D</b>
			<input type="checkbox"/> <b>COFMA-PK</b>
			<input checked="" type="checkbox"/> <b>INLI-BAS</b>
			<input type="checkbox"/> <b>INLI-NL</b>
			<input type="checkbox"/> <b>INLI-NLD</b>
			<input type="checkbox"/> <b>ARL-FLEX</b>
			<input type="checkbox"/> <b>RH-EE</b>
			<input type="checkbox"/> <b>RH-ETR</b>
			<input type="checkbox"/> <b>RH-MSR</b>
			<input type="checkbox"/> <b>RH-MTR</b>
			<input checked="" type="checkbox"/> <b>URH</b>
			<input type="checkbox"/> <b>SWIND-BS</b>
			<input type="checkbox"/> <b>SWIND-PS</b>

Standard Equipment       Optional Equipment

For more detailed information about cab and powertrain equipment, please refer to separate specification sheets.

For all possible options and combinations of options please consult your Volvo sales contact who can create a specification to match your requirements using the Volvo Sales Support system (VSS).

The factory reserves the right to modify design and change equipment without previous notification. The specification can vary from country to country.

# MODEL RANGE

FMX D13 64 Rigid X-high rear air FM 64 R3CAX

- VANMIR** Vanity mirror in front shelf lid.  
In sleeper cab on passenger side and in high/extra high cabs in middle section of the front shelf.
  - AS-FUS** One extra shelf in each of the two front upper storage compartments.  
Only 1 shelf if microwave oven mounted in one of the two compartments.
  - INFOT-PK** Preparation kit (bracket, security straps, power cable, antenna cable and aux cable) for mounting of a television above driver door.
- ### Cab Exterior
- **PAICS-B** Basic painting in a lightning grey colour of cab surrounding parts (mirror housings, insteps, bumper and if fitted bumper spoiler and sun visor).  
If fitted roof air deflector, side air deflector and chassis fairings are always painted in cab colour.
  - **GLAS-TIN** Tinted windows (front/side/rear)
  - AWIND-RF** Rear fixed window (without curtains)
  - DGLAS-L** Laminated door glass
  - **LOCK-MAN** Manual door locking
  - LOCK-MRP** Manual door locking with internal remote control (from driver side) of passenger door
  - LOCK-REM** Central door locking with remote control
  - **BUMP-HD** Heavy duty front bumper
  - AUXFS** Extra cab side foot-step
  - GUARD-EH** Guard plate for cooling pipes and oil sump
  - SIDEH-B** Guide rail on day cab driver side
  - SIDSTP-R** Side ladder and guide rail on on day cab driver side
  - **BUGNET** Radiator screen / Mosquito net (PVC coated fibreglass) in front of radiator
  - CTILTP-E** Electrical cab tilt pump
  - **CTILTP-M** Manual cab tilt pump
  - FCABS-A** Air front cab suspension
  - **FCABS-M** Mechanical cab suspension
  - RCABS-A** Air rear cab suspension
  - **RCABS-M** Mechanical rear cab suspension
  - MIRCOMFX** El heated & operated robust main rear view mirrors, electrically heated wide angle mirrors (both sides).  
Close view mirror on passenger side.
  - **MIRSTDX** Electrically heated robust main rear view mirrors and wide angle mirrors (both sides). Close view mirror on passenger side.
  - **AMIR-F20** Front close view mirror above windscreen, passenger side (radius 200 mm)
  - SUNV-H** Exterior transparent dark grey front sun visor
  - AD-ROOF** Roof air deflector. Design (length, height etc.) automatically calculated and varies depending on vehicle total height (chassis height, cab type, tyres etc).
  - AD-SIDEL** Long cab side air deflector
  - AD-SIDES** Short cab side air deflectors
  - **HL-BAS2** Halogen H1 head lamps (heavy duty)
  - HL-BASIC** Halogen H7 head lamps
  - HL-BHID2** Bi-Xenon head lamps, high intensity discharged (heavy duty)
  - HL-CLEAN** High pressure headlamp cleaner
  - HLP-ST** Steel headlamp protection
  - HL-ADJ** Adjustable headlamps to adjust the height of the light beam
  - **DRL-LED** V-shaped ("V-light") day running light (LED).  
Turned on low beam gives a dimmed "V-light".
  - **UDRIVL** Without auxiliary front driving lamps
- ASL-RF2** Two Hella H11 70W spot lamps in sign box (one on each side of the Globetrotter sign)
  - ASL-RFPK** Preparation kit for two spot lamps in sign box
  - BEACO2F** Two front roof mounted amber rotating beacon warning lamps. Mounted on accessory bracket if ordered, otherwise on cab roof on both sides of the hatch.
  - BEACO2R** Two rear roof mounted (on accessory bracket) amber warning lamps.  
Rotating beacon lamps mounted on sleeper cab.  
Flashing LED lamps mounted on high/extra high sleeper cabs.
  - BEACON-P** Prepared wiring (switch and connected relay included) for warning lamps on cab roof.  
Max load 300 W.
  - BEACONA4** Four roof mounted amber warning lamps.  
2 front mounted (on accessory bracket if ordered) rotating beacon lamps.  
2 rear mounted (on mandatory accessory bracket) rotating beacon lamps on sleeper cab.  
2 rear mounted (on mandatory accessory bracket) flashing LED lamps on high/xhigh sleeper cabs.
  - CABPT-R1** One front cab roof pass through on passenger side
  - **CABPT-R2** Two front cab roof pass throughs, one on each side
  - SPOTP-F** Spotlamp preparation in cab front, max 280W
  - SPOTP-R** Spotlamp preparation on cab roof, max 280W
  - SPOTP-RF** Spotlamp preparation on cab roof and in cab front, max 2x280W
  - ROS-IL** Illuminated roof sign with switch in radio shelf. Switch for turning on/off.
  - ROS-IL2** Preparation kit for installing an illuminated roof sign\*. It includes a prerouted cable harness, a switch and LED-lamps. The switch is connected in the radio shelf middle section. Switch cap with icon, are enclosed in cab. Lamps in sign are mounted. The stripe in the Globetrotter window is selected via the cab sign variants
  - ROS-ILP** Wiring preparation kit (wires and switch) for cab sign or roof air deflector illumination
  - CSGN-FMX** FMX decal in the cab roof sign area
  - **HORN-F1S** One front mounted (behind grille) single tone air horn, Jericho. Operated by steering wheel buttons.
  - HORN-R2S** Two roof mounted single tone chromed air horns. Operated by steering wheel buttons.
  - ANT-CBR** Right hand side roof mounted foldable antenna and cables for CB radio, single aerial.
  - ACCBR-AP** Front, middle & rear roof mounted accessory brackets
  - ACCBR-F** Front roof mounted accessory bracket
  - ACCBR-FM** Front & middle roof mounted accessory brackets
  - ACCBR-FR** Front & rear roof mounted accessory brackets
  - ACCBR-M** Middle roof mounted accessory bracket
  - ACCBR-R** Rear roof mounted accessory bracket
  - ACCBR-RM** Rear & middle roof mounted accessory brackets
  - REFS-CW** Reflecting white stripes mounted on cab side
  - REFS-TW** Reflecting white cab side stripes by-packed in cab
  - REFS-TY** Reflecting yellow cab side stripes by-packed in cab

### Superstructure preparations

- BP-MI02** Body Builder preparation package Mixer (02)
- BP-TI03** Body Builder preparation package Tipper (03)
- SRWL-PK** Wiring preparation for chassis mounted working lamps and a 3-position switch (On/Off/Reverse auto on).  
Max load 280W.
- SWL-2FW** Two H3 70W white front chassis mounted (LH/RH side) working lamps and a 2-position switch (On/Off)
- SWL-2RW** Two H3 70W white rear chassis mounted (LH/RH side) working lamps and a 2-position switch (On/Off)
- SWL-4W** Four H3 70W white front (2) and rear (2) chassis mounted (LH/RH side) working lamps and a 2-position switch (On/Off)
- SWL-PK** Wiring preparation for chassis mounted working lamps and a 2-position switch (On/Off). Max load 280W.
- WL-CHPK** Preparation kit (switch and cable) for working lamp, max 2x70

■ Standard Equipment                       Optional Equipment

For more detailed information about cab and powertrain equipment, please refer to separate specification sheets.

For all possible options and combinations of options please consult your Volvo sales contact who can create a specification to match your requirements using the Volvo Sales Support system (VSS).

The factory reserves the right to modify design and change equipment without previous notification. The specification can vary from country to country.

# MODEL RANGE

FMX D13 64 Rigid X-high rear air FM 64 R3CAX

- W. Connector on chassis at gearbox.
  - **WLC-H2A** Two H3/70W working lamps with amber coloured lens high mounted back of cab (switch incl).
  - **WLC-H2W** Two H3/70W working lamps, white lens high mounted back of cab (switch incl).
  - **WLC-PKCH** Preparation kit (cables and switch) for cab mounted chassis working lamp. Max load 280W.
  - **WLC-PKH** Preparation kit (cables and switch) for high mounted working lamps back of cab (pass through in cab rear roof included). Max load 280W.
  - **WLC-PKL** Preparation kit (cables and switch) for low mounted working lamps back of cab (pass through in cab rear wall included). Max load 280W.
  - **WLC-PKLH** Preparation kit (cables and switch) for low and high mounted working lamps back of cab (pass throughs in rear wall and rear roof included). Max load 280W.
  - **ECBB-BAS** Body builder electrical centre without any body builder module
  - **ECBB-HIG** Body builder electrical centre with cab body builder module
  - **BBCHAS1** One 7-pole connector for Body builder interface. Wiring harness routed from the bodybuilder electrical distribution box inside the cab to a connection point inside the right frame rail beside the gearbox.
  - **BBCHAS3** Three 7-pole connectors for Body builder interface. Wiring harness routed from the bodybuilder electrical distribution box inside the cab to a connection point inside the right frame rail beside the gearbox.
  - **BEPR-T2** Body builder electrical software preparation for tipper with remote control
  - **EXSTER** Support for external steering control via body builder module
  - **TD-BAS** Trailer detection without LED sensor
  - **TD-LED** Trailer detection with LED sensor
  - **FRFS-BS** Frame rail free space on both sides to give space for crane legs or other equipment.  
One front axle with day cab: 515/507 mm (L/R side).  
One front axle with long cab: 288/360 mm (L/R side).  
Two front axles with short cab: 632/572 mm (L/R side).  
Two front axles with long cab: 405/485 mm (L/R side).
  - **FBA-BTF** Lower front body attachments for torsionally flexible platform body
  - **FBA-BTSF** Lower front body attachments for torsionally semi-flexible body (van or curtainsider)
  - **HBA-FSFB** Holes for body attachments, flexible/semi-flexible body
  - **HBA-SB** Holes for body attachments, stiff body
  - **RBA-T2** Lower rear body attachments for helper frame
  - **CRANEPK1** Crane plates mounted to frame, interface for crane capacity up to 10 ton meter
  - **CRANEPK2** Crane plates mounted to frame, interface for crane capacity up to 20 ton meter
  - **CRANEPK4** Crane plates mounted to frame, interface for crane capacity up to 40 ton meter
  - **AUXL-SPK** Electrical preparation kit (wiring and a switch in dashboard) for snow plough lights.  
Preparation for installation of additional headlights and additional turning indicators.
  - **TAILPRE2** Tail lift preparation kit, wireless remote operation
  - **TAILPREP** Tail lift preparation kit, wire remote operation
  - **AESW2** Two Body builder bistable electrical switches (marked AUX1 / AUX2)
  - **AESW2PK** Two Body builder bistable electrical switches (marked AUX1/AUX2) and in an empty 4-group preparation another four bistable switches with dummy switch caps
  - **AUXSW-4** Wiring for 4 extra hardwired switches (from Body builder electrical centre to switch positions)
- Services**
- **TGW-4GWL** Telematics gateway with 4G modem
  - **TGW-PK** Telematics gateway preparation kit
  - **FMS-PK** Fleet Management System gateway, preparation kit
  - **DRUT** My truck app gives the driver instant status information and control of the vehicle remotely from a smartphone or tablet. The variant enables the My truck app to connect to the vehicle.

**VOLVO**

Volvo Truck Corporation

volvotrucks.com