

MODEL RANGE

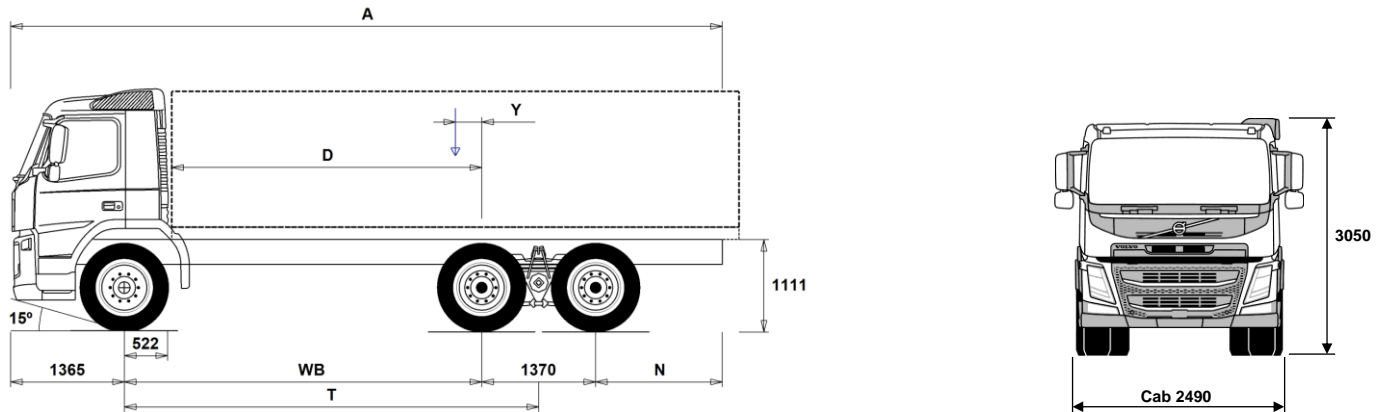

Volvo Trucks. Driving Progress

FM 11 6x4 Rigid - High T Ride - N3 Cranked front axle for on road work FM 64 R1HT



Chassis Dimensions [mm]

WB Wheelbase	3400	3700	3900	4300	4600	4900	5200	5600
A Overall Chassis Length	8010	8460	8760	9410	9860	10310	10810	11410
D Center of rear axle to front of body	2828	3128	3328	3728	4028	4328	4628	5028
N Rear Overhang (Min.)	1225	1225	1225	1225	1225	1225	1225	1225
N Rear Overhang (Max.)	1875	2025	2125	2375	2525	2675	2875	3075
T Theoretical Wheelbase	4085	4385	4585	4985	5285	5585	5885	6285
Y Center of Gravity for Payload (Min.)	-63	-21	7	63	104	144	186	238
Y Center of Gravity for Payload (Max.)	165	224	264	343	403	460	520	597

Chassis Weights [kg]

Front Axle	4270	4290	4305	4335	4355	4380	4395	4425
Rear Bogie	3815	3840	3855	3905	3935	3980	4010	4055
Kerb Weight	8085	8130	8160	8240	8290	8360	8405	8480
Payload (including body, driver, fuel, etc.)	17915	17870	17840	17760	17710	17640	17595	17520

Turning Diameter [mm]

Turning Circle Diameter Kerb to Kerb	14500	15500	16100	17300	18200	19100	20000	21300
Turning Circle Diameter Wall to Wall	16000	16900	17500	18700	19700	20600	21500	22700

Plated Weights [kg]

	Plated	Design
Gross Vehicle Weight	26000	34000
Gross Combination Weight	44000	44000
Front Axle	8000	8000
Rear Bogie	19000	26000

Important Notes

Chassis Dimensions

Cab Height: +416 mm for CAB-HSLP, -169 mm for CAB-LSLP.
Front Axle to Back of Cab: +424 mm for CAB-HSLP and CAB-SLP, +418 mm for CAB-LSLP.

D-measure includes a front clearance of 50 mm and for rigid trucks also a subframe of 100 mm.

Height can vary ± 20 mm for leaf and ± 10 mm for air suspension.

All dimensions are for unladen chassis and any tag axles down.

Rear overhang used for vehicle weight calculation is the maximum rear overhang (N Max.) for selected wheelbase.

Weight and dimensions are based upon the following tyres:

Front Axle Tyres: 315/80R22.5
Drive Axle Tyres: 315/80R22.5

Chassis weight includes oil, water, AdBlue, 0 litres fuel and without driver. Kerb weight can vary $\pm 3\%$.

Turning diameters are theoretically calculated.

Legal weights can differ from country to country.

For more detailed weight information, including optional equipment weights, ask your Volvo sales contact to enter your specification into the Volvo Weight Information system (WIS).

Do NOT use this drawing for bodybuilding. Refer to Volvo Bodybuilder Instructions and chassis assembly drawing FM64R1HT.

MODEL RANGE

FM 11 6x4 Rigid - High T Ride - N3 Cranked front axle for on road work FM 64 R1HT

TRUCK USE

- RC-ROUGH** Operating class on/off road
- RC-VROUG** Very rough road conditions
- TIPP-PRE** Tipper vehicle preparation
- UNIFORM** Basic platform vehicle

CORE COMPONENTS

- CHH-HIGH** Chassis height high - N3 "On Road" chassis - For a specific loading height always check the unique BEP chassis drawing
- RADD-TR1** T-ride 1 rear two spring bogie suspension, 75mm wide springs
- RADD-TR2** T-ride 3 rear two spring bogie suspension, reinforced
- FM-DAY** Day cab - with steel safety cage design
Designed and built to Swedish impact and ECE R29 regulations
- FM-HSLP** Globetrotter cab - with steel safety cage design
Designed and built to Swedish impact and ECE R29 regulations
- FM-LSLP** Low sleeper cab - with steel safety cage design
Designed and built to Swedish impact and ECE R29 regulations
- FM-SLP** Sleeper cab - with steel safety cage design
Designed and built to Swedish impact and ECE R29 regulations
- EU6SCR** Emission level - Euro 6
- D11K330** D11K330 10.8 litre engine developing 330hp at 16-1900rpm.
Peak torque 1600Nm at 950-1400rpm.
- D11K380** D11K380 10.8 litre engine developing 380hp at 17-1900rpm.
Peak torque 1800Nm at 950-1400rpm.
- D11K430** D11K430 10.8 litre engine developing 430hp at 17-1800rpm.
Peak torque 2050Nm at 1058-1400rpm.
- D11K460** D11K460 10.8 litre engine developing 450hp at 16-1800rpm.
Peak torque 2200Nm at 1050-1400rpm.
- EBR-EPG** Exhaust brake controlled by steering column switch
- EBR-EPGC** Exhaust pressure governor for I shift gearbox
- EBR-VEB** Volvo engine brake and exhaust pressure governor retardation 300kW
- AT2612F** AT2612F 12-speed "I-shift" automated mechanical gearbox suitable for gross train weights up to 60tonne only refer to sales engineering when used in conjunction with a PTO
- ATO2612F** ATO2612F 12-speed "I-shift" overdrive automated mechanical gearbox suitable for gross train weights up to 60tonne refer to sales engineering when used in conjunction with a PTO
- PT2106** Powertronic automatic 6-speed gearbox, max. engine torque 2100 Nm, max. permitted GCW 100000 kg
- RTH2610F** RTH2610F hub reduction tandem 26tonne drive axles, GCW 100 tonnes with differential and cross locks*
* Cross locks replaced by a dog clutch if tandem axle lift is specified
- RTH3210F** RTH3210F hub reduction tandem 32 tonne drive axles, GCW 100 tonnes with differential and cross locks*
* Cross locks replaced by a dog clutch if tandem axle lift is specified
- RTH3312** RTH3312 hub reduction tandem 33tonne drive axles, GCW 120 tonnes with differential and cross locks*
* Cross locks replaced by a dog clutch if tandem axle lift is specified
- RTS2370A** RTS2370A single reduction tandem 23tonne drive axles with differential and cross locks* - design GCW 70tonnes.
* Cross locks replaced by a dog clutch if tandem axle lift is specified.

PACKAGES

- DRIVEFM** Cab Package: Drive
- DRIVEFM+** Cab Package: Drive +
- BEDFM** One bed resting package
- AUDHIG** High Power Audio system: RDS radio with CD player - also

Standard Equipment Optional Equipment

For more detailed information about cab and powertrain equipment, please refer to separate specification sheets.

For all possible options and combinations of options please consult your Volvo sales contact who can create a specification to match your requirements using the Volvo Sales Support system (VSS).

The factory reserves the right to modify design and change equipment without previous notification. The specification can vary from country to country.

MEDIA

playing MP3/WMA files from CD -, with integrated bluetooth phone and USB/Line inputs. FM/AM antenna, speakers in dashboard, doors, and sleeping compartment.

MEDIADF

AM/FM Bluetooth radio without CD player.
USB and Aux line inputs.
Speakers in dashboard, doors, and sleeping compartment.
7" touch screen with personal apps.
AM/FM Bluetooth radio without CD player.
USB and Aux line inputs.
Speakers in dashboard, doors, and sleeping compartment.
7" touch screen with personal and professional apps.
Dynafleet vehicle on-board data display with office internet support.

MEDIANAV

AM/FM Bluetooth radio without CD player.
USB and Aux line inputs.
Speakers in dashboard, doors, and sleeping compartment.
7" touch screen with personal and professional apps.

MEDIANDF

Truck based satellite navigation (live updates not included)
AM/FM Bluetooth radio without CD player.
USB and Aux line inputs.
Speakers in dashboard, doors, and sleeping compartment.
7" touch screen with personal and professional apps.
Truck based satellite navigation (live updates not included)
Dynafleet vehicle on-board data display with office internet support.

VISI15

Visibility Package

RCHAPAC1

Chassis Package Rigid

CHASSIS

- FST-PAR** Front suspension type - 2 leaf parabolic springs
- FST-PAR3** Front suspension type - 3 leaf parabolic springs
- FAL10.0** Front axle design capacity 10 tonnes - Ensure that you have checked the tyre load index
- FAL7.1** Front axle design capacity 7.1 tonnes
- FAL7.5** Front axle design capacity 7.5 tonnes
- FAL8.0** Front axle design capacity 8.0 tonnes - Ensure that you have checked the tyre load index
- FAL8.5** Front axle design capacity 8.5 tonnes
- FAL9.0** Front axle design capacity 9.0 tonnes - Ensure that you have checked the tyre load index
- FSM-LUB** Lubricated rear shackles on front suspension pins and bushings
- FSTAB** Front anti-roll bar
- FSTAB2** Front anti-roll bar medium stiffness
- FSTAB3** Front stiff anti-roll bar
- RAL23** Rear bogie design capacity 23 tonnes
- RAL26** Rear bogie design capacity 26 tonnes
- RAL32** Rear bogie design capacity 32 tonnes
- RSTAB1** Rear anti-roll bar
- RSAP2** Heavy duty rear suspension application (with reinforcements)
- ACTST-TO** Volvo Dynamic Steering (VDS) with with extra electronic pump and torque overlay
- ASFE-BAS** Active steering feature - Basic - Volvo Dynamic Steering only
- ASFE-PS** Active steering feature - Volvo Dynamic Steering with personal settings
- PSS-SING** Single power steering system
- PSP-FIX** Power steering pump with fixed displacement
- PSP-VAR** Power steering pump with variable displacement
- EBS-MED** EBS medium package including "hill" hold function
- AUXPARK** Additional spring parking brakes
- RST-MUL** Rear Suspension, Multi-leaf springs
- RST-PAR1** Rear Suspension, Parabolic springs
- FBREG-E** Front regulating brake valve, EBS
- FBREG-RP** Front regulating brake valve, reduced pressure/low pressure range
- FRAME300** Frame rail section external height 300 mm

MODEL RANGE

FM 11 6x4 Rigid - High T Ride - N3 Cranked front axle for on road work FM 64 R1HT

- **FST8080** Frame thickness - web and flange 8.0mm
 - **FIL-EEEB** Inner liner from end of engine to end of bogie
 - **FIL-EEEF** Inner liner from end of engine to end of frame
 - **FIL-FBEB** Inner liner over rear bogie
 - **FIL-FBEF** Inner liner from front of bogie to end of frame
 - **FIL-TXEB** Inner liner from gearbox member to end of bogie
 - **FIL-TXEF** Inner liner from gearbox member to end of frame
 - **BBOX-L** Battery box located on left hand side
 - **2BAT210B** 2 x 210 Ah capacity Gel batteries
 - **2BATT170** 2 x 170 Ah capacity batteries
 - **2BATT225** 2 x 225 Ah capacity batteries
 - **BATTAMP** Battery voltage and ampere gauge
 - **BATTIND** Battery charge indication
 - **ADR2** ADR package for transportation of dangerous goods on road (Note does NOT include safe loading pass package if required this is quoted separately)
 - **MSWI-A** Main switch - ADR switch circuit shut down
 - **MSWI-C** Main switch - Chassis mounted toggle switch by battery box
 - **MSWI-R** Main switch - Key fob operated remote controlled
 - **R365A71** Right tank 365litre aluminium diameter 710mm
Min volume 255l
Max volume 885l
 - **UL-FUEL** Without left fuel tank
Min volume 160l
Max volume 730l
 - **ADTP-L** AdBlue tank on left hand side
 - **ADTP-R** AdBlue tank on right hand side
 - **ADB048** AdBlue tank usable volume 48 litres
 - **ADB064** AdBlue tank usable volume 64 litres
 - **ADB068** AdBlue tank usable volume 68 litres
 - **ADB090** AdBlue tank usable volume 90 litres
 - **FCAP-L** Locking fuel filler cap
 - **FUFF-AS** Fuel filling anti-spillage device
 - **FUFF-ATS** Fuel filling anti-theft and anti-spillage devices
 - **ESH-LEFT** Horizontal silencer, left exhaust outlet
 - **ESH-REAR** Horizontal silencer, rear exhaust outlet
 - **ESH-RIGH** Horizontal silencer, right exhaust outlet
 - **ESH-VERT** Horizontal silencer, vertical exhaust outlet
 - **EXST-SSP** Stainless steel exhaust stack - NOT polished
 - **EXST-ST** Steel exhaust stack
 - **HS-NAR** Narrow heat shield
 - **WHC-FIX2** Two fixed wheel chocks
 - **WHC-FOL2** Two foldable wheel chocks
 - **WHCP-F** Wheel chock(s) stored in the front part of the vehicle
 - **WHCP-M** Wheel chock(s) stored in the middle part of the vehicle
 - **WHCP-R** Wheel chock(s) stored in the rear part of the vehicle
 - **WHCP-T** Transport mounted wheel chock(s) stored in cab outer luggage locker
 - **TB-L80** Toolbox 800 mm, left side
 - **TB-R80** Toolbox 800 mm, right side
 - **SUP-BAS** EC approved chassis side guards
 - **CHAIN-S** Snow chains
 - **HOOK-SC** Snow chain hooks
 - **TOWF-NO1** One front towing device
 - **TOWF-NO2** Two front towing devices
 - **TOWMBR1** Towing member, high mounted in centre of frame, D = 190
 - **TOWMBRL1** Towing member, low mounted under the frame
 - **TOWMBRM** Towing member, medium mounted in line with frame lower flange
 - **RFEC-L** Rear frame end, lower flange cut for centre axle drawbar.
 - **RFEC-S** Rear frame end, straight cut for regular platform applications
 - **RFEC-U** Rear frame end, upper cut for tipper applications.
 - **C-RI4040** Towing coupling, Ringfeder 4040 G-150
 - **C-RI5055** Towing coupling, Ringfeder 5055 G-150
 - **C-RO400G** Towing coupling, Rockinger 400 G-150 for 40mm eyes
 - **C-RO50** Rockinger RO 50 50mm for centre axle trailer
 - **TOWR-ONE** Towing hitch attached to rear crossmember
 - **TREL-PK** Trailer electrical preparation kit - chassis/cab wiring
 - **TREL14** Single 14 pole electrical trailer connector
 - **TREL15** Single 15 pole electrical trailer connector - ADR certified
 - **TREL7** 7 pole - 24N trailer electrical suzie
 - **TREL7-7** 24N and 24S trailer electrical suzies
 - **TBC-DUO** Duomatic type air line connectors
 - **TBC-EC** Palm coupling type air line connectors
 - **TRBR-HCF** Full pressure hand controlled trailer brake
 - **TRBR-STA** Stationary trailer brake control
 - **TRB-STRE** Stretch Brake - Automatic low speed trailer brake activation to avoid jack-knifing and improve steerability
 - **RUP-FOLD** Folding EC approved aluminium rear underrun
 - **RUP-FOSL** Folding & sliding EC approved aluminium rear underrun
 - **RFEND-B** Three piece EC approved rear mud wings and spray flaps
 - **RFEND-T** Rear mud wings, transport mounted
 - **RFH-BAS** Basic rear wing height
 - **RFH-HIG** High rear wing height - higher wing tops
 - **RFH-LOW** Lower rear wing height - shallower wing tops
 - **ATANK-AL** Aluminium air tanks
 - **ATANK-ST** Steel air tanks
 - **REST-RUP**
 - **TL-LED** Rear lights LED
 - **BLIGHT-E** Emergency brake light
- ### WHEELS & TYRES
- **RT-AL** Alcoa brushed aluminium rims with standard holes for long stud fixing on all axles
 - **RT-ALDP** Alcoa Dura-Bright EVO aluminium rims with standard holes long stud fixing on all axles, requires cleaning with a ph neutral solution - washing up liquid.
 - **RT-ALDPD** Alcoa Dura-Bright EVO aluminium rims with countersunk holes for short stud fixing on all axles, requires cleaning with a ph neutral solution - washing up liquid.
 - **RT-ALDU** Alcoa brushed aluminium rims with countersunk holes for short stud fixing on all axles
 - **RT-SPOKE** Spoke rims on all axles
 - **RT-STEEL** Steel rims on all axles
 - **WCAP** Aerodynamic hub caps
 - **BRREC001** Bridgestone ECOPIA H - Energy rating C
 - **BRREC002** Bridgestone Ecopia H 002 Evo - Tyre recommendation 2
 - **COREC001** Continental ECOPLUS HS3 XL/HD3 - Energy rating B or C depending on size
 - **COREC002** Continental ECOPLUS HS3/HD3 - Energy rating B or C depending on size
 - **COREC003** Continental Efficient Pro S/D - Fuel Tyre Recommendation 3 Reduced mileage compared to Conti EcoPlus long haul pattern please consider when selecting these tyres.
 - **GYREC003** Goodyear FUELMAX S/(O)/D - Fuel tyre Recommendation 3
 - **GYREC004** Goodyear FUELMAX S - Energy rating B depending on size
 - **HAREC001** Hankook AL10+ E-Cube Max Long Haul Tyre - Energy rating B
 - **HAREC002** Hankook AL10+ E-Cube Long Haul Tyre - Energy rating B with wide single
 - **MIREC001** Michelin XFA2/X-LINE Energy - Fuel tyre Recommendation 1
 - **MIREC002** Michelin XZA2/X-LINE Energy - Fuel tyre Recommendation 2
 - **MIREC003** Michelin X-LINE Energy - Fuel tyre Recommendation 3
 - **MIREC004** Michelin X Line Energy F/D2 - Energy rating A
 - **PIREC001** Pirelli FH:01 Proway - Long Haul Tyre - Energy rating B
 - **PIREC002** Pirelli FH:01 II Long Haul Tyre - Energy rating B with wide single
- Standard Equipment □ Optional Equipment

For more detailed information about cab and powertrain equipment, please refer to separate specification sheets.

For all possible options and combinations of options please consult your Volvo sales contact who can create a specification to match your requirements using the Volvo Sales Support system (VSS).

The factory reserves the right to modify design and change equipment without previous notification. The specification can vary from country to country.

MODEL RANGE

FM 11 6x4 Rigid - High T Ride - N3 Cranked front axle for on road work FM 64 R1HT

<input type="checkbox"/> SPWT-D	Spare wheel & tyre with rear tyre pattern	<input type="checkbox"/> HPE-F51	engine mounted hydraulic pump Parker F1-51, engine mounted, fixed displacement, single flow,
<input type="checkbox"/> SPWT-F	Spare wheel & tyre with front tyre pattern	<input type="checkbox"/> HPE-F61	engine mounted hydraulic pump Parker F1-61, engine mounted, fixed displacement, single flow,
<input type="checkbox"/> SWCP-LF	Spare wheel carrier on left side of chassis ahead of rear axle	<input type="checkbox"/> HPE-F81	engine mounted hydraulic pump Parker F1-81, engine mounted, fixed displacement, single flow,
<input type="checkbox"/> SWCP-R	Rear mounted spare wheel carrier	<input type="checkbox"/> HPE-T53	engine mounted hydraulic pump Parker F2-53/53, engine mounted, Fixed displacement, Twin
<input type="checkbox"/> SWCP-T	Spare wheel supplied temporarily strapped to chassis	<input type="checkbox"/> HPE-T70	flow engine mounted hydraulic pump Parker F2-70/35, engine mounted, Fixed displacement, Twin
<input type="checkbox"/> SWCP-TP	Temporary spare wheel carrier on top of chassis frame	<input type="checkbox"/> HPE-V45	flow engine mounted hydraulic pump Parker VP1-45, variable displacement, single flow, engine
<input type="checkbox"/> JACK-12T	12 tonne bottle jack	<input type="checkbox"/> HPE-V75	mounted hydraulic pump Parker VP1-75, variable displacement, single flow, engine
<input type="checkbox"/> JACK-15T	15 tonne bottle jack	<input type="checkbox"/> PTPT-D	mounted hydraulic pump Powertronic PTO, 1 front/upper DIN connection for plug-in
<input type="checkbox"/> JACK-20T	20 tonne bottle jack	<input type="checkbox"/> PTPT-F	pump (max. 850 Nm) Powertronic PTO, 1 front/upper rear facing SAE flange conn.
<input checked="" type="checkbox"/> TOOL-BAS	Basic Toolkit	<input type="checkbox"/> PTR-D	for prop shaft (max.850 Nm) Gearbox PTO for plug-in pump, 0.71xeng speed
<input type="checkbox"/> TOOLKIT	Complete tool kit	<input type="checkbox"/> PTR-DH	Gearbox driven high speed PTO for one plug-in hydraulic
<input type="checkbox"/> INFLAHOS	Tyre inflation hose	<input type="checkbox"/> PTR-DM	pump Gearbox driven medium speed PTO for one plug-in hydraulic
<input type="checkbox"/> GAUGE-TP	Tyre pressure gauge	<input type="checkbox"/> PTR-F	pump Gearbox driven PTO with rear flange connection
DRIVELINE EQUIPMENT			
<input type="checkbox"/> TRAP-HD	Reinforced gearbox application	<input type="checkbox"/> PTR-FH	Gearbox driven high speed PTO with SAE drive flange
<input type="checkbox"/> TP-CON	Construction Package	<input type="checkbox"/> PTR-FL	Gearbox driven low speed PTO with SAE drive flange
<input type="checkbox"/> TP-DIST	Distribution Package	<input type="checkbox"/> PTRD-D	Gearbox driven HIGH SPEED PTO for two plug-in hydraulic
<input type="checkbox"/> TP-HD	I-shift software - Heavy duty for high GCW Special conditions apply consult Sales Engineering	<input type="checkbox"/> PTRD-D1	pumps PTRD-D1 Gearbox driven HIGH SPEED PTO (1 SAE flange &
<input type="checkbox"/> TP-LONG	Long Haul Package	<input type="checkbox"/> PTRD-D2	1 plug-in hydraulic pump) Gearbox driven HIGH SPEED PTO (2 SAE flanges & 1 plug-in
<input type="checkbox"/> AMSO-AUT	Enhanced I-shift software with manual shift available in auto mode and kickdown facility on accelerator pedal	<input type="checkbox"/> PTRD-F	hyd pump) PTO with 1 DIN + 1 flange connection rear, manual gearbox
<input type="checkbox"/> AVO-ENH	Enhanced software for off road driveability and starting	<input type="checkbox"/> HPG-F101	<input type="checkbox"/> HPG-F41
<input type="checkbox"/> APF-ENH	I-shift enhanced PTO functions	<input type="checkbox"/> HPG-F51	Parker F1-41 gearbox mounted, fixed displacement, single
<input type="checkbox"/> RET-TH	Gearbox mounted retarder	<input type="checkbox"/> HPG-F61	flow, hydraulic pump Parker F1-51 gearbox mounted, fixed displacement, single
<input type="checkbox"/> RET-TPT	Hydraulic Retarder for Powertronic gearbox	<input type="checkbox"/> HPG-F81	flow, hydraulic pump Parker F1-61 gearbox mounted, fixed displacement, single
<input type="checkbox"/> TC-HWO	Automatic gearbox oil cooler - water to oil	<input type="checkbox"/> EIDLESD	flow, hydraulic pump Parker F1-81 gearbox mounted, fixed displacement, single
<input type="checkbox"/> TC-MAOH2	Extra high performance transmission oil cooler - air to oil with front mounted radiator	<input type="checkbox"/> DTRI-PER	flow, hydraulic pump Engine idle shut down Dashboard in darker peregrine greyish brown. Steering wheel
<input type="checkbox"/> TC-MWO	Basic transmission oil cooler - water to oil	<input type="checkbox"/> STWPOS-R	grey and door panels in light beige for FH and black for FH16.
<input type="checkbox"/> 1COMP530	Single cylinder, air compressor, 530 litres per minute	<input type="checkbox"/> STWM-LE	RIGHT HAND DRIVE Leather steering wheel
<input type="checkbox"/> 2COM1100	Two cylinder, air compressor, 1100 litres per minute	<input type="checkbox"/> STGW-AD2	Adjustable steering wheel with neck tilt
<input checked="" type="checkbox"/> 2COMP900	Two cylinder, air compressor, 900 litres per minute	<input checked="" type="checkbox"/> STGW-ADJ	Adjustable steering wheel
<input type="checkbox"/> CLU-AIRC	Clutchable air compressor	<input checked="" type="checkbox"/> AIRBAG	SRS Driver's air bag
<input checked="" type="checkbox"/> AIRIN-HI	Roof mounted air intake behind cab on left hand side	<input checked="" type="checkbox"/> DRC-AMII	DPF Regeneration control switch - for manual and switching off
<input type="checkbox"/> AIRIN-LO	Low level air intake behind cab on left hand side	<input type="checkbox"/> 1DAYDIG2	regeneration Continental VDO DTCO 4.0 smart tachograph
<input type="checkbox"/> ACL1ST-S	Two stage air filter	<input type="checkbox"/> 1DAYDIGP	This tachograph can ONLY offer remote download if the option
<input checked="" type="checkbox"/> 24AL110B	110 amp alternator	<input type="checkbox"/> ARSL	of Dynafleet or an FMS gateway has been specified with this
<input checked="" type="checkbox"/> 24AL120B	120 amp alternator		order. Continental VDO DTCO 3.0 digital tachograph
<input type="checkbox"/> 24AL150B	150 amp alternator		For vehicles with long lead time - this includes prep kit for the
<input checked="" type="checkbox"/> CCV-C	Closed crankcase engine ventilation		retrofit of DTCO 4.0 tachograph. For updating to new legal demand for trick registration from
<input type="checkbox"/> CCV-OX	Closed crankcase ventilation for cold markets		15th June 2019. This tachograph can ONLY offer remote download if the option
<input checked="" type="checkbox"/> PRIM-EL	Electrical priming pump		of Dynafleet or an FMS gateway has been specified with this
<input type="checkbox"/> PRIM-MAN	Manual priming pump		order. Additional road speed limit - switch in dashboard
<input type="checkbox"/> FUEQ-EH	Fuel line electric heater		
<input type="checkbox"/> AF-R	Hot fuel recirculation heated fuel filter		
<input type="checkbox"/> FUEFE2LW	Large engine mounted dual fuel filter with water separator		
<input checked="" type="checkbox"/> FUEFE2SW	Small engine mounted dual fuel filter with water separator		
<input type="checkbox"/> EST-AID	Air inlet manifold starting heater element		
<input type="checkbox"/> 220EBH15	220V/1.5Kw electric engine block heater		
<input type="checkbox"/> PTER-100	Rear engine mounted power-take-off with DIN 100 / ISO 7646 flange		
<input type="checkbox"/> PTER-DIN	Rear engine mounted PTO with DIN5462 (female) splined shaft for a close coupled pump. Models with 3 steering axles will use this to drive the steering		
<input type="checkbox"/> PTER1400	Rear engine mounted power-take-off with SAE 1410 flange		
<input type="checkbox"/> HPE-F101	Parker F1-101, engine mounted, fixed displacement, single flow, engine mounted hydraulic pump		
<input type="checkbox"/> HPE-F41	Parker F1-41, engine mounted, fixed displacement, single flow,		

Standard Equipment

Optional Equipment

For more detailed information about cab and powertrain equipment, please refer to separate specification sheets.

For all possible options and combinations of options please consult your Volvo sales contact who can create a specification to match your requirements using the Volvo Sales Support system (VSS).

The factory reserves the right to modify design and change equipment without previous notification. The specification can vary from country to country.

MODEL RANGE

FM 11 6x4 Rigid - High T Ride - N3 Cranked front axle for on road work FM 64 R1HT

<input type="checkbox"/> SPEED-DU	Dual speed limiter		
<input type="checkbox"/> CRUIS-E	Eco cruise control (with eco-roll and l-cruise, controls in steering wheel)		
<input checked="" type="checkbox"/> CRUISEC	Cruise control, standard	<input type="checkbox"/> UPHTRI12	vinyl bolster with red vinyl side insert. Interior trim: Raven black bunk and curtains & grey vinyl side walls Seats: Blue soft textile insert, black vinyl bolster. Interior trim: Raven black bunk and curtains & blue textile side walls
<input checked="" type="checkbox"/> ESP-BAS1	Electronic Stability Control	<input type="checkbox"/> UPHTRI13	Seats: Dark grey leather insert and black leather bolster. Interior trim: Raven black bunk and curtains & grey vinyl side walls
<input type="checkbox"/> ESPC-RO	ESP (Electronic Stability Program) functionality control - Reduced / Off	<input type="checkbox"/> UPHTRI14	Seat: Dark grey leather insert and black leather bolster. Interior trim: Raven black bunk and curtains & blue textile side walls
<input type="checkbox"/> HWSS-ACB	Adaptive cruise control ACC with forward collision warning and AEBS advanced emergency brake system	<input checked="" type="checkbox"/> DST-CF4	Driver seat, comfort, suspended, belt in seat
<input checked="" type="checkbox"/> HWSS-FCB	Forward collision warning with AEBS advanced emergency brake system	<input type="checkbox"/> DST-CF5	Driver seat, comfort, suspended, belt in seat, electrically heated
<input checked="" type="checkbox"/> LSS-DW	Lane departure-warning system	<input type="checkbox"/> DST-CF6	Driver seat, comfort, suspended, belt in seat, electrically heated, ventilated
<input type="checkbox"/> LCS	Lane change support	<input type="checkbox"/> SBD-RED	Red seat belts
<input type="checkbox"/> DAS-W	Driver Alert Support system	<input type="checkbox"/> SBPRE-DS	Driver seat belt pretensioner
<input type="checkbox"/> RSENS-W	Rain sensing windscreen wipers	<input checked="" type="checkbox"/> PST-BAS1	Passenger seat - Fixed non suspended fold up with seatbelt mounted in cab
<input type="checkbox"/> CU-ECC	Electrically controlled air conditioning with sun sensor	<input type="checkbox"/> PST-BENC	Bench passenger seat
<input type="checkbox"/> CU-ECC2	Electrically controlled air conditioning with sun sensor, mist sensor, air quality sensor and carbon filter	<input type="checkbox"/> PST-CF4	Passenger seat - Comfort suspended with seatbelt mounted in seat
<input checked="" type="checkbox"/> CU-MCC	Climate unit with manual controlled air conditioning	<input type="checkbox"/> PST-CF5	Passenger seat - Comfort suspended & heated with seatbelt mounted in seat
<input checked="" type="checkbox"/> IMMOBIL	Thatcham H2 approved immobiliser	<input type="checkbox"/> PST-STD2	Passenger seat - Fixed non suspended with seatbelt mounted in cab
<input type="checkbox"/> ALARM-B	Thatcham H1 approved vehicle alarm - Cab only	<input type="checkbox"/> PST-STD4	Passenger seat - Standard suspended with seatbelt mounted in cab
<input type="checkbox"/> ALARM-E	Enhanced vehicle alarm - Thatcham H1 approved - Cab plus external sensor for body/trailer	<input type="checkbox"/> SBPRE-PS	Passenger seat belt pretensioner
<input type="checkbox"/> ALCOLOCK	Alcolock	<input type="checkbox"/> ARM-DBPS	Two armrests on driver seat and one (outer) on passenger seat
<input type="checkbox"/> BUPMON	Back up monitor with built in 7" screen on dash and one colour camera supplied loose for fitment by bodybuilder. Can accommodate up to 4 cameras for TfL Safe Scheme, CLOCS and FORS.	<input type="checkbox"/> ARMRE-BB	Two armrests on both driver and passenger seat.
<input type="checkbox"/> PHONE-PK	Telephone preparation kit (antenna, antenna attachm. cable incl.)	<input type="checkbox"/> ARMRE-DB	Two armrests, on driver seat only
<input type="checkbox"/> WLIFT-AD	Electrical window lift, automatic up/down driver side	<input type="checkbox"/> ARMRE-PB	Two armrests, on passenger seat only
<input checked="" type="checkbox"/> WLIFT-EB	Electrical window lift	<input type="checkbox"/> ARMRE-PS	Single armrest (next to driver) on passenger seat
<input type="checkbox"/> WLIFT-ME	Mechanical window lift	<input type="checkbox"/> ARU-BAS	Vinyl upholstered armrest
<input type="checkbox"/> ISUNS-BS	Side interior sun visor on both sides	<input type="checkbox"/> ARU-LEA	Leather upholstered armrest
<input checked="" type="checkbox"/> ISUNS-DS	Driver's side interior sun visor	<input checked="" type="checkbox"/> FMAT-RUB	Rubber floor mats
<input checked="" type="checkbox"/> ISUNF-B	Interior front sun visor without mirror	<input type="checkbox"/> FMAT-TX2	Textile and rubber floor mats
<input type="checkbox"/> ISUNF-MD	Interior front sun visor with mirror on driver side	<input type="checkbox"/> LBK-RES	Foldable rest bunk
<input type="checkbox"/> ISUNF-RE	Electrically operated textile interior sun blind	<input type="checkbox"/> LBK70	Lower bunk 700 x2000 mm, fixed
<input type="checkbox"/> ISUNF-RM	Manually operated textile interior sun blind	<input checked="" type="checkbox"/> ULBK	Without lower bunk
<input type="checkbox"/> ADFS	Two extra DIN slots in front shelf - can be fitted with card or drawer available as an accessory	<input type="checkbox"/> MATL-FI	Firm lower bunk pocket sprung mattress
<input checked="" type="checkbox"/> BUPALARM	Reverse alarm	<input type="checkbox"/> MATL-SF	Lower flexizone mattress - semi-firm, pocket springs up to 100kg - 16 stone
<input type="checkbox"/> RTOLL-PK	Road toll PREPARATION kit for trucks operating with "Toll Collect" in Germany	<input type="checkbox"/> MATL-SO	Lower flexizone mattress - soft, pocket springs up to 85kg - 13.5 stone
<input type="checkbox"/> REMC-MF	Multi-functio wireless remote control	<input type="checkbox"/> OLMAT-BA	35mm mattress overlay protector
<input type="checkbox"/> FIREXT3S	3kg fire extinguisher mounted on seat base	<input type="checkbox"/> OLMAT-PR	50mm premium mattress overlay protector
<input type="checkbox"/> WARNVEST	High visibility warning vest - no sleeves	<input type="checkbox"/> TBK60F	Fixed foldable top bunk 600 x 1900mm
<input type="checkbox"/> AIDKIT	First aid kit	<input type="checkbox"/> TBK70F	Fixed foldable top bunk 700 x 1900mm
<input type="checkbox"/> AIDKIT1B	First aid kit	<input type="checkbox"/> PH-CAB2	1.8kW Air to air night heater
<input type="checkbox"/> WARNLAMP	Portable warning lamp	<input type="checkbox"/> PH-ENGCA	Engine and cab night heater
<input type="checkbox"/> LAMP-IN	Inspection lamp	<input type="checkbox"/> PH-SS	Short stop heater
<input type="checkbox"/> BULBKIT	Bulb and fuse kit	<input type="checkbox"/> SLCP-BAS	Basic sleeper control panel - includes interior light, parking heater, roof hatch and door lock
<input type="checkbox"/> WRITEPAD	Writing pad	<input type="checkbox"/> SAFE	Safe box for driver's personal items
<input type="checkbox"/> UPHTRI10	Seats: Black embossed textile insert with light grey sides, black vinyl side bolster with blue vinyl side insert. Interior trim: Raven black bunk and curtains & blue textile side walls	<input type="checkbox"/> ETSB-F	Storage on engine tunnel - on front top
<input type="checkbox"/> UPHTRI11	Seats: Light grey embossed textile insert, black raven metallic	<input type="checkbox"/> ETSB-FR	Storage on engine tunnel - on front top and at rear cab wall
		<input type="checkbox"/> ETSB-FRS	Storage on engine tunnel - on front top & at rear cab wall & storage recessed into tunnel on right hand side
		<input type="checkbox"/> ETSB-FS	Storage on engine tunnel - on front top and storage recessed into tunnel on right hand side
		<input type="checkbox"/> ETSB-R	Storage on engine tunnel - box at rear cab wall

Standard Equipment

Optional Equipment

For more detailed information about cab and powertrain equipment, please refer to separate specification sheets.

For all possible options and combinations of options please consult your Volvo sales contact who can create a specification to match your requirements using the Volvo Sales Support system (VSS).

The factory reserves the right to modify design and change equipment without previous notification.
The specification can vary from country to country.

MODEL RANGE

FM 11 6x4 Rigid - High T Ride - N3 Cranked front axle for on road work FM 64 R1HT

- ETSB-RS** Storage on engine tunnel - at rear cab wall and storage recessed into tunnel on right hand side
 - ETSB-S** Storage on engine tunnel - recessed into tunnel on right hand side
 - RUS-BAS** Rear cab upper storage 154 litres - 300 mm high
 - RUS-HIG** Rear cab upper storage 245 litres - 440 mm high
 - TABLE** Folding and height adjustable table - on lower bunk
 - REF-ICPK** Fridge: engine tunnel mounted preparation kit
 - REFR-RUS** Fridge: 28 litre rear upper wall mounted with dividers
 - MICRO-PK** Preparation kit for microwave oven (wiring)
 - BOTH-D** One bottle holder under dashboard centre section
 - COFMA-PK** Coffee maker, preparation kit.
 - INLI-BAS** Interior white LED lights - basic
 - INLI-NL** Interior white and red night LED light with no dimmer
 - INLI-NLD** Interior white and red night LED light with dimmer
 - ARL-FLEX** Two flexible reading lamps (snake lamps)
 - RH-ECS** Glass roof & escape hatch - Electrically operated
 - RH-EE** Without roof hatch -Tinted glass emergency exit ONLY
 - RH-ETR** Glass roof & escape hatch - Electrically operated, tinted glass with rear opening
 - RH-MSR** Steel roof & escape hatch - Manually operated with rear opening
 - RH-MTR** Glass roof & escape hatch - Manually operated, tinted glass with rear opening
 - URH** Without roof hatch
 - SWIND-BS** Extra side window on both sides behind "B" pillar
 - SWIND-PS** Rear side window, passenger side
 - VANMIR** Vanity mirror in front shelf
 - AS-FUS** Extra shelf in front upper storage compartments
 - INFOT-PK** Preparation kit for the mounting of a flat screen TV in cab above the driver's door, includes bracket, electrical and speaker connections
- CAB EXTERIOR**
- PAICS-B** Basic cab paint - mirrors, sunvisor, instep and bumper supplied in natural finish - grey
 - PAICS-C** Complete cab - mirrors, insteps, sunvisor, and bumper finished in cab colour
 - GLAS-TIN** Tinted windows.
 - AWIND-RF** Rear window
 - DGLAS-L** Laminated door glass
 - LOCK-MAN** Manual door locking
 - LOCK-MRP** Manual door locking with internal remote control (from driver side) of passenger door
 - LOCK-REM** Central locking with remote control
 - BUMP-B** Plastic front bumper
 - BUMP-B2** Steel front bumper
 - BUMP-SP** Front bumper spoiler
 - GUARD-EH** Engine guard to protect sump and engine hoses
 - BUGNET** Insect screen in front of radiator
 - CTILT-P-E** Electrically operated hydraulic cab tilt
 - CTILT-P-M** Manually operated hydraulic cab tilt
 - FCABS-A** Front cab suspension - Air
 - FCABS-M** Front cab suspension - Mechanical spring
 - RCABS-A** Rear cab suspension - Air
 - RCABS-M** Rear cab suspension - Mechanical spring
 - MIRCOMF2** Electrically heated and operated FMX style main and wide-angle mirror on both sides, with manual passenger kerb mirror. To increase direct vision to the side the main mirrors have no cowlings
 - MIRCOMFM** Electrically heated and operated main with manual wide-angle mirror - both sides - and passenger kerb mirror
 - MIRSTD2** Electrically heated - FMX - main with wide angle mirror on both sides and kerb view mirror on passenger side, to increase direct vision to the side the main mirrors have no cowlings
 - MIRSTDFM** Electrically heated main mirror with wide angle mirror on both sides and kerb view mirror on passenger side
 - AMIR-F20** Auxiliary front view mirror with a 200mm radius
 - SUNV-H** External smoke grey sunvisor
 - AD-ROOF** Roof air deflector
 - AD-SIDEL** Side air deflector extension panels
 - AD-SIDES** Short cab side air deflector for rigid bodywork
 - HL-BASIC** Halogen H7 head lamps
 - HL-CLEAN** Head lamp cleaner - washer jets
 - HLP-ST** Headlamp protection
 - HL-ADJ** Headlight adjustment - Switch in cab
 - DRIVL2** Two spot lamps
 - UDRIVL** Without auxiliary driving lights
 - FOGL-WC** Front fog lights
 - CL-STAT** Static corner lights
 - ASL-RF2** Two Hella H11 70W spotlamps in sign box - only available with the basic headlight and no lower driving lights.
 - ASL-RFPK** Preparation kit for two spotlamps in sign box
 - BEACOA2F** Two front roof mounted amber beacon rotating warning lamps
 - BEACOA2R** Two rear roof mounted (on accessory bracket) amber beacon flashing warning LED lamps
 - BEACON-P** Roof beacon wire preparation
 - BEACONA4** Four roof mounted (2 front/2 rear) amber beacon rotating warning lamps
 - CABPT-R1** Single outlet for roof mounted accessories
 - CABPT-R2** Twin outlets for roof mounted accessories.
 - SPOTP-F** Spotlamp preparation in front, max 280W
 - SPOTP-R** Spotlamp preparation on roof, max 280W
 - SPOTP-RF** Spotlamp preparation on cab roof and in cab front, max 2x280W
 - ROS-IL2** Preparation kit for illuminated roof sign with switch loose in cab, fit after registration
 - CSGN-GTR** "Globetrotter" headboard logo
 - HORN-F1S** Single tone Jericho air horn chassis mounted
 - HORN-R2S** Two roof mounted air horns
 - ANT-CBR** Roof mounted antenna for CB radio, single aerial
 - ACCBP-AP** Front, middle & rear roof mounted accessory brackets
 - ACCBP-F** Front roof mounted accessory bracket
 - ACCBP-FM** Front & middle roof mounted accessory brackets
 - ACCBP-FR** Front & rear roof mounted accessory brackets
 - ACCBP-M** Middle roof mounted accessory bracket
 - ACCBP-R** Rear roof mounted accessory bracket
 - ACCBP-RM** Rear & middle roof mounted accessory brackets
 - REFS-TW** White cab conspicuity markings by packed in cab
 - REFS-TY** Yellow cab conspicuity markings by packed in cab
- SUPERSTRUCTURE PREPARATIONS**
- BP-MI02**
 - BP-TI03**
 - SRWL-PK** Wiring preparation for side & rear work/reverse lamps on side of chassis and a three-position switch, maximum 280W
 - SWL-2FW** Two H3 70W white front chassis mounted (LH/RH side) working lamps and a 2-position switch (On/Off)
 - SWL-2RW** Two H3 70W white rear chassis mounted (LH/RH side) working lamps and a 2-position switch (On/Off)
 - SWL-4W** 4 H3 70W white front (2) & rear (2) chassis mtd (LH/RH side) working lamps & 2-pos switch (On/Off)
 - SWL-PK** Wiring preparation for side work/reverse lamps on side of

Standard Equipment Optional Equipment

For more detailed information about cab and powertrain equipment, please refer to separate specification sheets.

For all possible options and combinations of options please consult your Volvo sales contact who can create a specification to match your requirements using the Volvo Sales Support system (VSS).

The factory reserves the right to modify design and change equipment without previous notification. The specification can vary from country to country.

MODEL RANGE

FM 11 6x4 Rigid - High T Ride - N3 Cranked front axle for on road work FM 64 R1HT

- chassis
and a three-position switch, maximum 280W
- WLC-H2A** Two H3/70W working lamps with amber coloured lens high mounted back of cab
- WLC-H2W** Two H3/70W white working lamps high mounted on the back of cab
- WLC-PKCH** Preparation kit (cables and switch) for cab mounted chassis working lamp
- WLC-PKH** Preparation kit, cables and switch for high mounted working lamps back of cab
- WLC-PKL** Preparation kit, cables and switch for low mounted working lamps back of cab
- WLC-PKLH** Preparation kit - cables and switch for low and high mounted working lamps back of cab.
- ECBB-BAS** Body builder electrical centre without body builder module
- ECBB-HIG** Body builder electrical centre with body builder module
- BBCHAS1** One 7-pole connector for Body builder interface
- BBCHAS3** Three 7-pole connectors for Body builder interface
- BEPR-T2** Body builder electrical software preparation for tipper with remote control
- EXSTER** External steering control, with VDS and bodybuilder module
- TD-BAS** Trailer detection WITHOUT LED sensing
- TD-LED** Trailer detection with LED sensing
- FRFS-BS** Frame rail free space on both sides to give space for crane legs or other equipment.
- FBA-BTF** Lower front body attachments for torsionally flexible - platform body
- FBA-BTSF** Lower front body attachments for torsionally semi-flexible body - box or curtainsider
- HBA-FSFB** Holes for body attachments - flexible/semi-flexible body
- HBA-SB** Holes for body attachments - stiff body
- RBA-T2** Lower rear body attachments for helper frame
- CRANEPK1** Crane plates mounted to frame, for cranes up to 10 tonne metre capacity
- CRANEPK2** Crane plates mounted to frame, for cranes up to 20 tonne metre capacity
- CRANEPK4** Crane plates mounted to frame, for cranes up to 40 tonne metre capacity
- AUXL-SPK** Electrical preparation kit - wiring and switch for snow plough lights
- TAILPRE2** Tail lift preparation kit, wireless remote operation
- TAILPREP** Taillift preparation kit - cab switch and warning in driver display
- AESW2** Two Body builder bistable electrical switches (marked AUX1 / AUX2)
- AESW2PK** 2 Body builder bistable el.switches (marked AUX1/AUX2) and prep. for 4 more switches
- AUXSW-4** Wiring for 4 extra switches (from Body builder electrical centre to switch positions)

DELIVERY SERVICES

- TGW-4GWL** GSM/GPRS/4G modem, LTE & WLAN for telematics gateway
- FMS-PK** Fleet Management System gateway

VOLVO

Volvo Truck Corporation
volvotrucks.com