

# MODEL RANGE

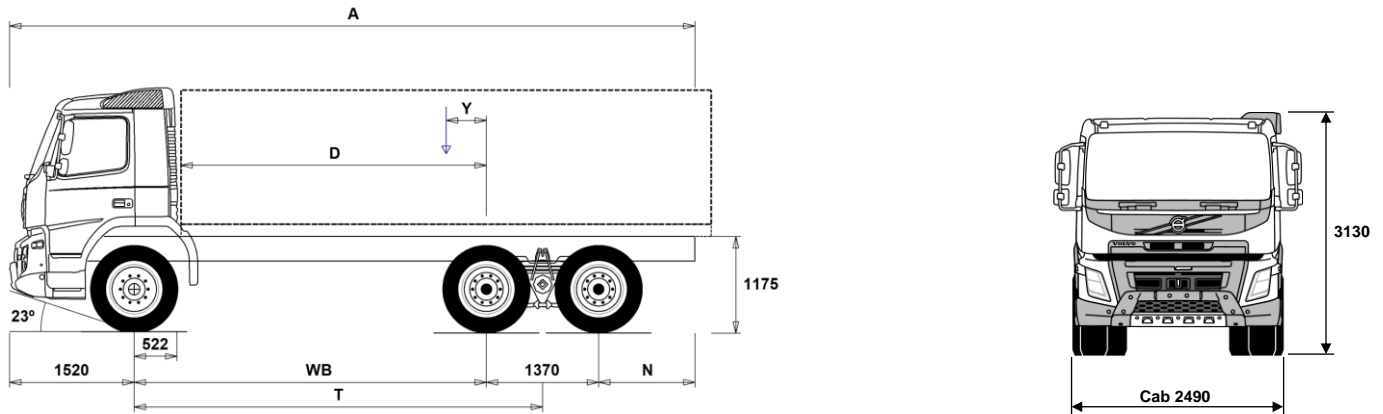

Volvo Trucks. Driving Progress

FMX11 6x4 Rigid - X-High T Ride - N3G Straight front axle FM 64 R1CTX



## Chassis Dimensions [mm]

WB Wheelbase	3400	3700	3900	4300	4600
A Overall Chassis Length	7465	7765	7965	8365	8665
D Center of rear axle to front of body	2828	3128	3328	3728	4028
N Rear Overhang (Min.)	825	825	825	825	825
N Rear Overhang (Max.)	1175	1175	1175	1175	1175
T Theoretical Wheelbase	4085	4385	4585	4985	5285
Y Center of Gravity for Payload (Min.)	-94	-56	-31	19	57
Y Center of Gravity for Payload (Max.)	137	193	230	304	359

## Chassis Weights [kg]

Front Axle	4445	4470	4490	4520	4545
Rear Bogie	3910	3920	3925	3950	3965
Kerb Weight	8355	8390	8415	8470	8510
Payload (including body, driver, fuel, etc.)	17645	17610	17585	17530	17490

## Turning Diameter [mm]

Turning Circle Diameter Kerb to Kerb	14500	15500	16100	17300	18200
Turning Circle Diameter Wall to Wall	16000	16900	17500	18800	19700

## Plated Weights [kg]

	Plated	Design
Gross Vehicle Weight	26000	34000
Gross Combination Weight	44000	50000
Front Axle	8000	8000
Rear Bogie	19000	26000

## Important Notes

### Chassis Dimensions

Cab Height: +416 mm for CAB-HSLP.

Front Axle to Back of Cab: +424 mm for CAB-HSLP and CAB-SLP.

D-measure includes a front clearance of 50 mm and for rigid trucks also a subframe of 100 mm.

Height can vary  $\pm 20$  mm for leaf and  $\pm 10$  mm for air suspension.

All dimensions are for unladen chassis and any tag axles down.

Rear overhang used for vehicle weight calculation is the maximum rear overhang (N Max.) for selected wheelbase.

Weight and dimensions are based upon the following tyres:

Front Axle Tyres: 315/80R22.5

Drive Axle Tyres: 315/80R22.5

**Chassis weight includes oil, water, AdBlue, 0 litres fuel and without driver. Kerb weight can vary  $\pm 3\%$ .**

Turning diameters are theoretically calculated.

Legal weights can differ from country to country.

For more detailed weight information, including optional equipment weights, ask your Volvo sales contact to enter your specification into the Volvo Weight Information system (WIS).

Do NOT use this drawing for bodybuilding. Refer to Volvo Bodybuilder Instructions and chassis assembly drawing FM64R1CTX.

# MODEL RANGE

FMX11 6x4 Rigid - X-High T Ride - N3G Straight front axle FM 64 R1CTX

## TRUCK USE

- RC-ROUGH** Operating class on/off road
- RC-VROUG** Very rough road conditions
- **TIPP-PRE** Tipper vehicle preparation

## CORE COMPONENTS

- **CHH-XHIG** Chassis height X-High - For a specific loading height always check the unique BEP chassis drawing
- **RADD-TR1** T-ride 1 rear two spring bogie suspension, 75mm wide springs
- RADD-TR2** T-ride 3 rear two spring bogie suspension, reinforced
- **FMX-DAY** Day cab - with steel safety cage design  
Designed and built to Swedish impact and ECE R29 regulations
- FMX-HSLP** Globetrotter cab - with steel safety cage design  
Designed and built to Swedish impact and ECE R29 regulations
- FMX-SLP** Sleeper cab - with steel safety cage design  
Designed and built to Swedish impact and ECE R29 regulations
- **EU6SCR** Emission level - Euro 6
- **D11K330** D11K330 10.8 litre engine developing 330hp at 16-1900rpm.  
Peak torque 1600Nm at 950-1400rpm.
- D11K380** D11K380 10.8 litre engine developing 380hp at 17-1900rpm.  
Peak torque 1800Nm at 950-1400rpm.
- D11K430** D11K430 10.8 litre engine developing 430hp at 17-1800rpm.  
Peak torque 2050Nm at 1058-1400rpm.
- D11K460** D11K460 10.8 litre engine developing 450hp at 16-1800rpm.  
Peak torque 2200Nm at 1050-1400rpm.
- EBR-EPG** Exhaust brake controlled by steering column switch
- EBR-EPGC** Exhaust pressure governor for I shift gearbox
- EBR-VEB** Volvo engine brake and exhaust pressure governor retardation 300kW
- **AT2612F** AT2612F 12-speed "I-shift" automated mechanical gearbox suitable for gross train weights up to 60tonne only refer to sales engineering when used in conjunction with a PTO
- ATO2612F** ATO2612F 12-speed "I-shift" overdrive automated mechanical gearbox suitable for gross train weights up to 60tonne refer to sales engineering when used in conjunction with a PTO
- PT2106** Powertronic automatic 6-speed gearbox, max. engine torque 2100 Nm, max. permitted GCW 100000 kg
- **RTH2610F** RTH2610F hub reduction tandem 26tonne drive axles, GCW 100 tonnes with differential and cross locks\*  
\* Cross locks replaced by a dog clutch if tandem axle lift is specified
- RTH3210F** RTH3210F hub reduction tandem 32 tonne drive axles, GCW 100 tonnes with differential and cross locks\*  
\* Cross locks replaced by a dog clutch if tandem axle lift is specified
- RTH3312** RTH3312 hub reduction tandem 33tonne drive axles, GCW 120 tonnes with differential and cross locks\*  
\* Cross locks replaced by a dog clutch if tandem axle lift is specified
- RTS2370A** RTS2370A single reduction tandem 23tonne drive axles with differential and cross locks\* - design GCW 70tonnes.  
\* Cross locks replaced by a dog clutch if tandem axle lift is specified.

## PACKAGES

- DRIVEFM** Cab Package: Drive
- DRIVEFM+** Cab Package: Drive +
- BEDFM** One bed resting package
- AUDHIG** High Power Audio system: RDS radio with CD player - also playing MP3/WMA files from CD -, with integrated bluetooth phone and USB/Line inputs. FM/AM antenna, speakers in dashboard, doors, and sleeping compartment.
- MEDIA** AM/FM Bluetooth radio without CD player.

■ Standard Equipment       Optional Equipment

For more detailed information about cab and powertrain equipment, please refer to separate specification sheets.

For all possible options and combinations of options please consult your Volvo sales contact who can create a specification to match your requirements using the Volvo Sales Support system (VSS).

The factory reserves the right to modify design and change equipment without previous notification. The specification can vary from country to country.

- MEDIADF** USB and Aux line inputs.  
Speakers in dashboard, doors, and sleeping compartment.  
7" touch screen with personal apps.  
AM/FM Bluetooth radio without CD player.  
USB and Aux line inputs.  
Speakers in dashboard, doors, and sleeping compartment.  
7" touch screen with personal and professional apps.  
Dynafleet vehicle on-board data display with office internet support.
- MEDIANAV** AM/FM Bluetooth radio without CD player.  
USB and Aux line inputs.  
Speakers in dashboard, doors, and sleeping compartment.  
7" touch screen with personal and professional apps.  
Truck based satellite navigation (live updates not included)
- MEDIANDF** AM/FM Bluetooth radio without CD player.  
USB and Aux line inputs.  
Speakers in dashboard, doors, and sleeping compartment.  
7" touch screen with personal and professional apps.  
Truck based satellite navigation (live updates not included)  
Dynafleet vehicle on-board data display with office internet support.

## CHASSIS

- **FST-PAR3** Front suspension type - 3 leaf parabolic springs
- FAL10.0** Front axle design capacity 10 tonnes - Ensure that you have checked the tyre load index
- **FAL8.0** Front axle design capacity 8.0 tonnes - Ensure that you have checked the tyre load index
- FAL9.0** Front axle design capacity 9.0 tonnes - Ensure that you have checked the tyre load index
- FSM-LUB** Lubricated rear shackles on front suspension pins and bushings
- **FSTAB** Front anti-roll bar
- FSTAB2** Front anti-roll bar medium stiffness
- FSTAB3** Front stiff anti-roll bar
- RAL23** Rear bogie design capacity 23 tonnes
- **RAL26** Rear bogie design capacity 26 tonnes
- RAL32** Rear bogie design capacity 32 tonnes
- **RSTAB1** Rear anti-roll bar
- RSAP2** Heavy duty rear suspension application (with reinforcements)
- ACTST-TO** Volvo Dynamic Steering (VDS) with with extra electronic pump and torque overlay
- ASFE-BAS** Active steering feature - Basic - Volvo Dynamic Steering only
- ASFE-PS** Active steering feature - Volvo Dynamic Steering with personal settings
- **PSS-SING** Single power steering system
- **PSP-FIX** Power steering pump with fixed displacement
- PSP-VAR** Power steering pump with variable displacement
- **EBS-MED** EBS medium package including "hill" hold function
- AUXPARK** Additional spring parking brakes
- RST-MUL** Rear Suspension, Multi-leaf springs
- **RST-PAR1** Rear Suspension, Parabolic springs
- **FBREG-E** Front regulating brake valve, EBS
- FBREG-RP** Front regulating brake valve, reduced pressure/low pressure range
- **FRAME300** Frame rail section external height 300 mm
- **FST8080** Frame thickness - web and flange 8.0mm
- FIL-EEEB** Inner liner from end of engine to end of bogie
- FIL-EEEF** Inner liner from end of engine to end of frame
- FIL-FBEB** Inner liner over rear bogie
- FIL-FBEF** Inner liner from front of bogie to end of frame
- **FIL-TXEB** Inner liner from gearbox member to end of bogie
- FIL-TXEF** Inner liner from gearbox member to end of frame
- **BBOX-L** Battery box located on left hand side

# MODEL RANGE

## FMX11 6x4 Rigid - X-High T Ride - N3G Straight front axle FM 64 R1CTX

<input type="checkbox"/> <b>2BAT210B</b>	2 x 210 Ah capacity Gel batteries	<input type="checkbox"/> <b>TREL7</b>	7 pole - 24N trailer electrical suzie
<input type="checkbox"/> <b>2BATT170</b>	2 x 170 Ah capacity batteries	<input type="checkbox"/> <b>TREL7-7</b>	24N and 24S trailer electrical suzies
<input type="checkbox"/> <b>2BATT225</b>	2 x 225 Ah capacity batteries	<input type="checkbox"/> <b>TBC-DUO</b>	Duomatic type air line connectors
<input checked="" type="checkbox"/> <b>BATTAMP</b>	Battery voltage and ampere gauge	<input type="checkbox"/> <b>TBC-EC</b>	Palm coupling type air line connectors
<input type="checkbox"/> <b>BATTIND</b>	Battery charge indication	<input type="checkbox"/> <b>TRBR-HCF</b>	Full pressure hand controlled trailer brake
<input type="checkbox"/> <b>ADR2</b>	ADR package for transportation of dangerous goods on road (Note does NOT include safe loading pass package if required this is quoted separately)	<input type="checkbox"/> <b>TRBR-STA</b>	Stationary trailer brake control
<input type="checkbox"/> <b>MSWI-A</b>	Main switch - ADR switch circuit shut down	<input type="checkbox"/> <b>TRB-STRE</b>	Stretch Brake - Automatic low speed trailer brake activation to avoid jack-knifing and improve steerability
<input checked="" type="checkbox"/> <b>MSWI-C</b>	Main switch - Chassis mounted toggle switch by battery box	<input type="checkbox"/> <b>RUP-FOLD</b>	Folding EC approved aluminium rear underrun
<input type="checkbox"/> <b>MSWI-R</b>	Main switch - Key fob operated remote controlled	<input type="checkbox"/> <b>RUP-FOSL</b>	Folding & sliding EC approved aluminium rear underrun
<input checked="" type="checkbox"/> <b>R315A56</b>	Right aluminium 560 mm D-shaped fuel tank, 315 litres volume Min volume 255l Max volume 885l	<input type="checkbox"/> <b>RFEND-B</b>	Three piece EC approved rear mud wings and spray flaps
<input checked="" type="checkbox"/> <b>UL-FUEL</b>	Without left fuel tank Min volume 160l Max volume 730l	<input type="checkbox"/> <b>RFEND-T</b>	Rear mud wings, transport mounted
<input type="checkbox"/> <b>ADTP-L</b>	AdBlue tank on left hand side	<input type="checkbox"/> <b>RFH-BAS</b>	Basic rear wing height
<input checked="" type="checkbox"/> <b>ADTP-R</b>	AdBlue tank on right hand side	<input type="checkbox"/> <b>RFH-HIG</b>	High rear wing height - higher wing tops
<input checked="" type="checkbox"/> <b>ADB048</b>	AdBlue tank usable volume 48 litres	<input type="checkbox"/> <b>RFH-LOW</b>	Lower rear wing height - shallower wing tops
<input type="checkbox"/> <b>ADB064</b>	AdBlue tank usable volume 64 litres	<input type="checkbox"/> <b>ATANK-AL</b>	Aluminium air tanks
<input type="checkbox"/> <b>ADB068</b>	AdBlue tank usable volume 68 litres	<input checked="" type="checkbox"/> <b>ATANK-ST</b>	Steel air tanks
<input type="checkbox"/> <b>ADB090</b>	AdBlue tank usable volume 90 litres	<input type="checkbox"/> <b>REST-RUP</b>	
<input type="checkbox"/> <b>ADB100</b>	AdBlue tank usable volume 100 litres	<input checked="" type="checkbox"/> <b>TL-LED</b>	Rear lights LED
<input checked="" type="checkbox"/> <b>FCAP-L</b>	Locking fuel filler cap	<input type="checkbox"/> <b>BLIGHT-E</b>	Emergency brake light
<input checked="" type="checkbox"/> <b>FUFF-AS</b>	Fuel filling anti-spillage device	<b>WHEELS &amp; TYRES</b>	
<input type="checkbox"/> <b>FUFF-ATS</b>	Fuel filling anti-theft and anti-spillage devices	<input type="checkbox"/> <b>RT-AL</b>	Alcoa brushed aluminium rims with standard holes for long stud fixing on all axles
<input type="checkbox"/> <b>ESH-LEFT</b>	Horizontal silencer, left exhaust outlet	<input type="checkbox"/> <b>RT-ALDP</b>	Alcoa Dura-Bright EVO aluminium rims with standard holes long stud fixing on all axles, requires cleaning with a ph neutral solution - washing up liquid.
<input checked="" type="checkbox"/> <b>ESH-REAR</b>	Horizontal silencer, rear exhaust outlet	<input type="checkbox"/> <b>RT-ALDPD</b>	Alcoa Dura-Bright EVO aluminium rims with countersunk holes for short stud fixing on all axles, requires cleaning with a ph neutral solution - washing up liquid.
<input type="checkbox"/> <b>ESH-RIGH</b>	Horizontal silencer, right exhaust outlet	<input type="checkbox"/> <b>RT-ALDU</b>	Alcoa brushed aluminium rims with countersunk holes for short stud fixing on all axles
<input type="checkbox"/> <b>ESH-VERT</b>	Horizontal silencer, vertical exhaust outlet	<input type="checkbox"/> <b>RT-SPOKE</b>	Spoke rims on all axles
<input type="checkbox"/> <b>EXST-SSP</b>	Stainless steel exhaust stack - NOT polished	<input checked="" type="checkbox"/> <b>RT-STEEL</b>	Steel rims on all axles
<input type="checkbox"/> <b>EXST-ST</b>	Steel exhaust stack	<input type="checkbox"/> <b>WCAP</b>	Aerodynamic hub caps
<input type="checkbox"/> <b>HS-NAR</b>	Narrow heat shield	<input type="checkbox"/> <b>BRREC001</b>	Bridgestone ECOPIA H - Energy rating C
<input type="checkbox"/> <b>WHC-FIX2</b>	Two fixed wheel chocks	<input type="checkbox"/> <b>BRREC002</b>	Bridgestone Ecopia H 002 Evo - Tyre recommendation 2
<input type="checkbox"/> <b>WHC-FOL2</b>	Two foldable wheel chocks	<input type="checkbox"/> <b>COREC002</b>	Continental ECOPLUS HS3/HD3 - Energy rating B or C depending on size
<input type="checkbox"/> <b>WHCP-F</b>	Wheel chock(s) stored in the front part of the vehicle	<input type="checkbox"/> <b>GYREC001</b>	Goodyear FUELMAX S/HL/D - Energy rating B or C depending on size
<input type="checkbox"/> <b>WHCP-M</b>	Wheel chock(s) stored in the middle part of the vehicle	<input type="checkbox"/> <b>GYREC002</b>	Goodyear FUELMAX S/D - Energy rating B or C depending on size
<input type="checkbox"/> <b>WHCP-R</b>	Wheel chock(s) stored in the rear part of the vehicle	<input type="checkbox"/> <b>GYREC003</b>	Goodyear FUELMAX S/(O)/D - Fuel tyre Recommendation 3
<input type="checkbox"/> <b>WHCP-T</b>	Transport mounted wheel chock(s) stored in cab outer luggage locker	<input type="checkbox"/> <b>HAREC001</b>	Hankook AL10+ E-Cube Max Long Haul Tyre - Energy rating B
<input type="checkbox"/> <b>TB-L80</b>	Toolbox 800 mm, left side	<input type="checkbox"/> <b>HAREC002</b>	Hankook AL10+ E-Cube Long Haul Tyre - Energy rating B with wide single
<input type="checkbox"/> <b>TB-R80</b>	Toolbox 800 mm, right side	<input type="checkbox"/> <b>MIREC002</b>	Michelin XZA2/X-LINE Energy - Fuel tyre Recommendation 2
<input type="checkbox"/> <b>CHAIN-S</b>	Snow chains	<input type="checkbox"/> <b>MIREC003</b>	Michelin X-LINE Energy - Fuel tyre Recommendation 3
<input type="checkbox"/> <b>HOOK-SC</b>	Snow chain hooks	<input type="checkbox"/> <b>MIREC004</b>	Michelin X Line Energy F/D2 - Energy rating A
<input checked="" type="checkbox"/> <b>TOWF-HD1</b>	One heavy duty front towing device	<input type="checkbox"/> <b>PIREC001</b>	Pirelli FH:01 Proway - Long Haul Tyre - Energy rating B
<input type="checkbox"/> <b>TOWMBRH</b>	Towing member, high mounted in centre of frame, D = 190	<input type="checkbox"/> <b>PIREC002</b>	Pirelli FH:01 II Long Haul Tyre - Energy rating B with wide single
<input type="checkbox"/> <b>TOWMBRL1</b>	Towing member, low mounted under the frame	<input type="checkbox"/> <b>SPWT-D</b>	Spare wheel & tyre with rear tyre pattern
<input type="checkbox"/> <b>TOWMBRM</b>	Towing member, medium mounted in line with frame lower flange	<input type="checkbox"/> <b>SPWT-F</b>	Spare wheel & tyre with front tyre pattern
<input type="checkbox"/> <b>RFEC-L</b>	Rear frame end, lower flange cut for centre axle drawbar.	<input type="checkbox"/> <b>SWCP-LF</b>	Spare wheel carrier on left side of chassis ahead of rear axle
<input checked="" type="checkbox"/> <b>RFEC-S</b>	Rear frame end, straight cut for regular platform applications	<input type="checkbox"/> <b>SWCP-R</b>	Rear mounted spare wheel carrier
<input type="checkbox"/> <b>RFEC-U</b>	Rear frame end, upper cut for tipper applications.	<input type="checkbox"/> <b>SWCP-T</b>	Spare wheel supplied temporarily strapped to chassis
<input type="checkbox"/> <b>C-RI4040</b>	Towing coupling, Ringfeder 4040 G-150	<input type="checkbox"/> <b>SWCP-TP</b>	Temporary spare wheel carrier on top of chassis frame
<input type="checkbox"/> <b>C-RI5055</b>	Towing coupling, Ringfeder 5055 G-150	<input type="checkbox"/> <b>JACK-12T</b>	12 tonne bottle jack
<input type="checkbox"/> <b>C-RO400G</b>	Towing coupling, Rockinger 400 G-150 for 40mm eyes	<input type="checkbox"/> <b>JACK-15T</b>	15 tonne bottle jack
<input type="checkbox"/> <b>C-RO50</b>	Rockinger RO 50 50mm for centre axle trailer	<input type="checkbox"/> <b>JACK-20T</b>	20 tonne bottle jack
<input type="checkbox"/> <b>TOWR-ONE</b>	Towing hitch attached to rear crossmember	<input checked="" type="checkbox"/> <b>TOOL-BAS</b>	Basic Toolkit
<input checked="" type="checkbox"/> <b>TREL-PK</b>	Trailer electrical preparation kit - chassis/cab wiring	<input type="checkbox"/> <b>TOOLKIT</b>	Complete tool kit
<input type="checkbox"/> <b>TREL14</b>	Single 14 pole electrical trailer connector	<input type="checkbox"/> <b>INFLAHOS</b>	Tyre inflation hose
<input type="checkbox"/> <b>TREL15</b>	Single 15 pole electrical trailer connector - ADR certified		

Standard Equipment

Optional Equipment

For more detailed information about cab and powertrain equipment, please refer to separate specification sheets.

For all possible options and combinations of options please consult your Volvo sales contact who can create a specification to match your requirements using the Volvo Sales Support system (VSS).

The factory reserves the right to modify design and change equipment without previous notification. The specification can vary from country to country.

# MODEL RANGE

FMX11 6x4 Rigid - X-High T Ride - N3G Straight front axle FM 64 R1CTX

<input type="checkbox"/> <b>GAUGE-TP</b>	Tyre pressure gauge	<input type="checkbox"/> <b>PTPT-D</b>	Powertronic PTO, 1 front/upper DIN connection for plug-in pump (max. 850 Nm)
<input type="checkbox"/> <b>TRAP-HD</b>	Reinforced gearbox application	<input type="checkbox"/> <b>PTPT-F</b>	Powertronic PTO, 1 front/upper rear facing SAE flange conn. for prop shaft (max.850 Nm)
<input type="checkbox"/> <b>TP-CON</b>	Construction Package	<input type="checkbox"/> <b>PTR-D</b>	Gearbox PTO for plug-in pump, 0.71xeng speed
<input type="checkbox"/> <b>TP-DIST</b>	Distribution Package	<input type="checkbox"/> <b>PTR-DH</b>	Gearbox driven high speed PTO for one plug-in hydraulic pump
<input type="checkbox"/> <b>TP-HD</b>	I-shift software - Heavy duty for high GCW	<input type="checkbox"/> <b>PTR-DM</b>	Gearbox driven medium speed PTO for one plug-in hydraulic pump
<input type="checkbox"/> <b>TP-LONG</b>	Special conditions apply consult Sales Engineering	<input type="checkbox"/> <b>PTR-F</b>	Gearbox driven PTO with rear flange connection
<input type="checkbox"/> <b>AMSO-AUT</b>	Long Haul Package	<input type="checkbox"/> <b>PTR-FH</b>	Gearbox driven high speed PTO with SAE drive flange
<input type="checkbox"/> <b>AVO-ENH</b>	Enhanced I-shift software with manual shift available in auto mode and kickdown facility on accelerator pedal	<input type="checkbox"/> <b>PTR-FL</b>	Gearbox driven low speed PTO with SAE drive flange
<input type="checkbox"/> <b>APF-ENH</b>	Enhanced software for off road driveability and starting	<input type="checkbox"/> <b>PTRD-D</b>	Gearbox driven HIGH SPEED PTO for two plug-in hydraulic pumps
<input type="checkbox"/> <b>RET-TH</b>	I-shift enhanced PTO functions	<input type="checkbox"/> <b>PTRD-D1</b>	Gearbox driven PTO with rear flange connection
<input type="checkbox"/> <b>RET-TPT</b>	Gearbox mounted retarder	<input type="checkbox"/> <b>PTRD-D2</b>	Gearbox driven high speed PTO with SAE drive flange
<input type="checkbox"/> <b>TC-HWO</b>	Hydraulic Retarder for Powertronic gearbox	<input type="checkbox"/> <b>PTRD-F</b>	Gearbox driven HIGH SPEED PTO for two plug-in hydraulic pumps
<input type="checkbox"/> <b>TC-MAOH2</b>	Automatic gearbox oil cooler - water to oil	<input type="checkbox"/> <b>PTRD-D1</b>	PTRD-D1 Gearbox driven HIGH SPEED PTO (1 SAE flange & 1 plug-in hydraulic pump)
<input type="checkbox"/> <b>TC-MWO</b>	Extra high performance transmission oil cooler - air to oil with front mounted radiator	<input type="checkbox"/> <b>PTRD-D2</b>	Gearbox driven HIGH SPEED PTO (2 SAE flanges & 1 plug-in hyd pump)
<input type="checkbox"/> <b>1COMP530</b>	Basic transmission oil cooler - water to oil	<input type="checkbox"/> <b>PTRD-F</b>	PTO with 1 DIN + 1 flange connection rear, manual gearbox
<input type="checkbox"/> <b>2COM1100</b>	Single cylinder, air compressor, 530 litres per minute	<input type="checkbox"/> <b>HPG-F101</b>	Parker F1-101 gearbox mounted, fixed displacement, single flow, hydraulic pump
<input type="checkbox"/> <b>2COMP900</b>	Two cylinder, air compressor, 1100 litres per minute	<input type="checkbox"/> <b>HPG-F41</b>	Parker F1-41 gearbox mounted, fixed displacement, single flow, hydraulic pump
<input type="checkbox"/> <b>CLU-AIRC</b>	Two cylinder, air compressor, 900 litres per minute	<input type="checkbox"/> <b>HPG-F51</b>	Parker F1-51 gearbox mounted, fixed displacement, single flow, hydraulic pump
<input type="checkbox"/> <b>AIRIN-HI</b>	Clutchable air compressor	<input type="checkbox"/> <b>HPG-F61</b>	Parker F1-61 gearbox mounted, fixed displacement, single flow, hydraulic pump
<input type="checkbox"/> <b>AIRIN-LO</b>	Roof mounted air intake behind cab on left hand side	<input type="checkbox"/> <b>HPG-F81</b>	Parker F1-81 gearbox mounted, fixed displacement, single flow, hydraulic pump
<input type="checkbox"/> <b>ACL1ST-S</b>	Low level air intake behind cab on left hand side	<input type="checkbox"/> <b>EIDLESD</b>	Engine idle shut down
<input type="checkbox"/> <b>24AL110B</b>	Two stage air filter	<input checked="" type="checkbox"/> <b>STWPOS-R</b>	RIGHT HAND DRIVE
<input type="checkbox"/> <b>24AL120B</b>	110 amp alternator	<input type="checkbox"/> <b>STWM-LE</b>	Leather steering wheel
<input type="checkbox"/> <b>24AL150B</b>	120 amp alternator	<input type="checkbox"/> <b>STGW-AD2</b>	Adjustable steering wheel with neck tilt
<input checked="" type="checkbox"/> <b>CCV-C</b>	150 amp alternator	<input checked="" type="checkbox"/> <b>STGW-ADJ</b>	Adjustable steering wheel
<input type="checkbox"/> <b>CCV-OX</b>	Closed crankcase engine ventilation	<input checked="" type="checkbox"/> <b>AIRBAG</b>	SRS Driver's air bag
<input checked="" type="checkbox"/> <b>PRIM-EL</b>	Closed crankcase ventilation for cold markets	<input checked="" type="checkbox"/> <b>DRC-AMII</b>	DPF Regeneration control switch - for manual and switching off regeneration
<input type="checkbox"/> <b>PRIM-MAN</b>	Electrical priming pump	<input checked="" type="checkbox"/> <b>1DAYDIG2</b>	Continental VDO DTCO 4.0 smart tachograph This tachograph can ONLY offer remote download if the option of Dynafleet or an FMS gateway has been specified with this order.
<input type="checkbox"/> <b>FUEQ-EH</b>	Manual priming pump	<input type="checkbox"/> <b>1DAYDIGP</b>	Continental VDO DTCO 3.0 digital tachograph For vehicles with long lead time - this includes prep kit for the retrofit of DTCO 4.0 tachograph. For updating to new legal demand for trick registration from 15th June 2019. This tachograph can ONLY offer remote download if the option of Dynafleet or an FMS gateway has been specified with this order.
<input type="checkbox"/> <b>AF-R</b>	Fuel line electric heater	<input type="checkbox"/> <b>ARSL</b>	Additional road speed limit - switch in dashboard
<input type="checkbox"/> <b>FUEFE2LW</b>	Hot fuel recirculation heated fuel filter	<input type="checkbox"/> <b>SPEED-DU</b>	Dual speed limiter
<input checked="" type="checkbox"/> <b>FUEFE2SW</b>	Large engine mounted dual fuel filter with water separator	<input type="checkbox"/> <b>CRUIS-E</b>	Eco cruise control (with eco-roll and I-cruise, controls in steering wheel)
<input type="checkbox"/> <b>EST-AID</b>	Small engine mounted dual fuel filter with water separator	<input checked="" type="checkbox"/> <b>CRUISEC</b>	Cruise control, standard
<input type="checkbox"/> <b>220EBH15</b>	Air inlet manifold starting heater element	<input type="checkbox"/> <b>ESP-BAS1</b>	Electronic Stability Control
<input type="checkbox"/> <b>PTER-100</b>	220V/1.5Kw electric engine block heater	<input type="checkbox"/> <b>ESPC-RO</b>	ESP (Electronic Stability Program) functionality control - Reduced / Off
<input type="checkbox"/> <b>PTER-DIN</b>	Rear engine mounted power-take-off with DIN 100 / ISO 7646 flange	<input type="checkbox"/> <b>HWSS-ACB</b>	Adaptive cruise control ACC with forward collision warning and AEBS advanced emergency brake system
<input type="checkbox"/> <b>PTER1400</b>	Rear engine mounted PTO with DIN5462 (female) splined shaft for a close coupled pump. Models with 3 steering axles will use this to drive the steering pump (AUXPSP)	<input type="checkbox"/> <b>HWSS-FCB</b>	Forward collision warning with AEBS advanced emergency brake system
<input type="checkbox"/> <b>HPE-F101</b>	Rear engine mounted power-take-off with SAE 1410 flange	<input type="checkbox"/> <b>LSS-DW</b>	Lane departure-warning system
<input type="checkbox"/> <b>HPE-F41</b>	Parker F1-101, engine mounted, fixed displacement, single flow, engine mounted hydraulic pump	<input type="checkbox"/> <b>LCS</b>	Lane change support
<input type="checkbox"/> <b>HPE-F51</b>	Parker F1-41, engine mounted, fixed displacement, single flow, engine mounted hydraulic pump		
<input type="checkbox"/> <b>HPE-F61</b>	Parker F1-51, engine mounted, fixed displacement, single flow, engine mounted hydraulic pump		
<input type="checkbox"/> <b>HPE-F81</b>	Parker F1-61, engine mounted, fixed displacement, single flow, engine mounted hydraulic pump		
<input type="checkbox"/> <b>HPE-T53</b>	Parker F1-81, engine mounted, fixed displacement, single flow, engine mounted hydraulic pump		
<input type="checkbox"/> <b>HPE-T70</b>	Parker F2-53/53, engine mounted, Fixed displacement, Twin flow engine mounted hydraulic pump		
<input type="checkbox"/> <b>HPE-V45</b>	Parker F2-70/35, engine mounted, Fixed displacement, Twin flow engine mounted hydraulic pump		
<input type="checkbox"/> <b>HPE-V75</b>	Parker VP1-45, variable displacement, single flow, engine mounted hydraulic pump		
	Parker VP1-75, variable displacement, single flow, engine mounted hydraulic pump		

Standard Equipment       Optional Equipment

For more detailed information about cab and powertrain equipment, please refer to separate specification sheets.

For all possible options and combinations of options please consult your Volvo sales contact who can create a specification to match your requirements using the Volvo Sales Support system (VSS).

The factory reserves the right to modify design and change equipment without previous notification. The specification can vary from country to country.

# MODEL RANGE

## FMX11 6x4 Rigid - X-High T Ride - N3G Straight front axle FM 64 R1CTX

<input type="checkbox"/> <b>DAS-W</b>	Driver Alert Support system	<input type="checkbox"/> <b>SBD-RED</b>	Red seat belts
<input type="checkbox"/> <b>RSSENS-W</b>	Rain sensing windscreen wipers	<input type="checkbox"/> <b>SBPRE-DS</b>	Driver seat belt pretensioner
<input type="checkbox"/> <b>CU-ECC</b>	Electrically controlled air conditioning with sun sensor	<input checked="" type="checkbox"/> <b>PST-BAS1</b>	Passenger seat - Fixed non suspended fold up with seatbelt mounted in cab
<input type="checkbox"/> <b>CU-ECC2</b>	Electrically controlled air conditioning with sun sensor, mist sensor, air quality sensor and carbon filter	<input type="checkbox"/> <b>PST-BENC</b>	Bench passenger seat
<input checked="" type="checkbox"/> <b>CU-MCC</b>	Climate unit with manual controlled air conditioning	<input type="checkbox"/> <b>PST-CF4</b>	Passenger seat - Comfort suspended with seatbelt mounted in seat
<input checked="" type="checkbox"/> <b>IMMOBIL</b>	Thatcham H2 approved immobiliser	<input type="checkbox"/> <b>PST-CF5</b>	Passenger seat - Comfort suspended & heated with seatbelt mounted in seat
<input type="checkbox"/> <b>ALARM-B</b>	Thatcham H1 approved vehicle alarm - Cab only	<input type="checkbox"/> <b>PST-STD2</b>	Passenger seat - Fixed non suspended with seatbelt mounted in cab
<input type="checkbox"/> <b>ALARM-E</b>	Enhanced vehicle alarm - Thatcham H1 approved - Cab plus external sensor for body/trailer	<input type="checkbox"/> <b>PST-STD4</b>	Passenger seat - Standard suspended with seatbelt mounted in cab
<input type="checkbox"/> <b>ALCOLOCK</b>	Alcolock	<input type="checkbox"/> <b>SBPRE-PS</b>	Passenger seat belt pretensioner
<input type="checkbox"/> <b>BUPMON</b>	Back up monitor with built in 7" screen on dash and one colour camera supplied loose for fitment by bodybuilder. Can accommodate up to 4 cameras for TFL Safe Scheme, CLOCS and FORS.	<input type="checkbox"/> <b>ARM-DBPS</b>	Two armrests on driver seat and one (outer) on passenger seat
<input type="checkbox"/> <b>PHONE-PK</b>	Telephone preparation kit (antenna, antenna attachm. cable incl.)	<input type="checkbox"/> <b>ARMRE-BB</b>	Two armrests on both driver and passenger seat.
<input type="checkbox"/> <b>WLIFT-AD</b>	Electrical window lift, automatic up/down driver side	<input type="checkbox"/> <b>ARMRE-DB</b>	Two armrests, on driver seat only
<input checked="" type="checkbox"/> <b>WLIFT-EB</b>	Electrical window lift	<input type="checkbox"/> <b>ARMRE-PB</b>	Two armrests, on passenger seat only
<input type="checkbox"/> <b>WLIFT-ME</b>	Mechanical window lift	<input type="checkbox"/> <b>ARMRE-PS</b>	Single armrest (next to driver) on passenger seat
<input type="checkbox"/> <b>ISUNS-BS</b>	Side interior sun visor on both sides	<input type="checkbox"/> <b>ARU-BAS</b>	Vinyl upholstered armrest
<input checked="" type="checkbox"/> <b>ISUNS-DS</b>	Driver's side interior sun visor	<input type="checkbox"/> <b>ARU-LEA</b>	Leather upholstered armrest
<input checked="" type="checkbox"/> <b>ISUNF-B</b>	Interior front sun visor without mirror	<input checked="" type="checkbox"/> <b>FMAT-RU2</b>	Rubber floor mats, extended
<input type="checkbox"/> <b>ISUNF-MD</b>	Interior front sun visor with mirror on driver side	<input type="checkbox"/> <b>FMAT-RUB</b>	Rubber floor mats
<input type="checkbox"/> <b>ISUNF-RE</b>	Electrically operated textile interior sun blind	<input type="checkbox"/> <b>FMAT-T2E</b>	
<input type="checkbox"/> <b>ISUNF-RM</b>	Manually operated textile interior sun blind	<input type="checkbox"/> <b>FMAT-TX2</b>	Textile and rubber floor mats
<input type="checkbox"/> <b>ADFS</b>	Two extra DIN slots in front shelf - can be fitted with card or drawer available as an accessory	<input type="checkbox"/> <b>LBK-RES</b>	Foldable rest bunk
<input checked="" type="checkbox"/> <b>BUPALARM</b>	Reverse alarm	<input type="checkbox"/> <b>LBK70</b>	Lower bunk 700 x2000 mm, fixed
<input type="checkbox"/> <b>RTOLL-PK</b>	Road toll PREPARATION kit for trucks operating with "Toll Collect" in Germany	<input checked="" type="checkbox"/> <b>ULBK</b>	Without lower bunk
<input type="checkbox"/> <b>REMC-MF</b>	Multi-functio wireless remote control	<input type="checkbox"/> <b>MATL-FI</b>	Firm lower bunk pocket sprung mattress
<input type="checkbox"/> <b>FIREXT3S</b>	3kg fire extinguisher mounted on seat base	<input type="checkbox"/> <b>MATL-SF</b>	Lower flexizone mattress - semi-firm, pocket springs up to 100kg - 16 stone
<input type="checkbox"/> <b>WARNVEST</b>	High visibility warning vest - no sleeves	<input type="checkbox"/> <b>MATL-SO</b>	Lower flexizone mattress - soft, pocket springs up to 85kg - 13.5 stone
<input type="checkbox"/> <b>AIDKIT</b>	First aid kit	<input type="checkbox"/> <b>OLMAT-BA</b>	35mm mattress overlay protector
<input type="checkbox"/> <b>AIDKIT1B</b>	First aid kit	<input type="checkbox"/> <b>OLMAT-PR</b>	50mm premium mattress overlay protector
<input type="checkbox"/> <b>WARNLAMP</b>	Portable warning lamp	<input type="checkbox"/> <b>TBK60F</b>	Fixed foldable top bunk 600 x 1900mm
<input type="checkbox"/> <b>LAMP-IN</b>	Inspection lamp	<input type="checkbox"/> <b>TBK70F</b>	Fixed foldable top bunk 700 x 1900mm
<input type="checkbox"/> <b>BULBKIT</b>	Bulb and fuse kit	<input type="checkbox"/> <b>PH-CAB2</b>	1.8kW Air to air night heater
<input type="checkbox"/> <b>WRITEPAD</b>	Writing pad	<input type="checkbox"/> <b>PH-ENGCA</b>	Engine and cab night heater
<input type="checkbox"/> <b>UPHTRI10</b>	Seats: Black embossed textile insert with light grey sides, black vinyl side bolster with blue vinyl side insert. Interior trim: Raven black bunk and curtains & blue textile side walls	<input type="checkbox"/> <b>PH-SS</b>	Short stop heater
<input checked="" type="checkbox"/> <b>UPHTRI11</b>	Seats: Light grey embossed textile insert, black raven metallic vinyl bolster with red vinyl side insert. Interior trim: Raven black bunk and curtains & grey vinyl side walls	<input type="checkbox"/> <b>SLCP-BAS</b>	Basic sleeper control panel - includes interior light, parking heater, roof hatch and door lock
<input type="checkbox"/> <b>UPHTRI12</b>	Seats: Blue soft textile insert, black vinyl bolster. Interior trim: Raven black bunk and curtains & blue textile side walls	<input type="checkbox"/> <b>SAFE</b>	Safe box for driver's personal items
<input type="checkbox"/> <b>UPHTRI13</b>	Seats: Dark grey leather insert and black leather bolster. Interior trim: Raven black bunk and curtains & grey vinyl side walls	<input type="checkbox"/> <b>ETSB-F</b>	Storage on engine tunnel - on front top
<input type="checkbox"/> <b>UPHTRI14</b>	Seat: Dark grey leather insert and black leather bolster. Interior trim: Raven black bunk and curtains & blue textile side walls	<input type="checkbox"/> <b>ETSB-FR</b>	Storage on engine tunnel - on front top and at rear cab wall
<input checked="" type="checkbox"/> <b>DST-CF4</b>	Driver seat, comfort, suspended, belt in seat	<input type="checkbox"/> <b>ETSB-FRS</b>	Storage on engine tunnel - on front top & at rear cab wall & storage recessed into tunnel on right hand side
<input type="checkbox"/> <b>DST-CF5</b>	Driver seat, comfort, suspended, belt in seat, electrically heated	<input type="checkbox"/> <b>ETSB-FS</b>	Storage on engine tunnel - on front top and storage recessed into tunnel on right hand side
<input type="checkbox"/> <b>DST-CF6</b>	Driver seat, comfort, suspended, belt in seat, electrically heated, ventilated	<input type="checkbox"/> <b>ETSB-R</b>	Storage on engine tunnel - box at rear cab wall
		<input type="checkbox"/> <b>ETSB-RS</b>	Storage on engine tunnel - at rear cab wall and storage recessed into tunnel on right hand side
		<input type="checkbox"/> <b>ETSB-S</b>	Storage on engine tunnel - recessed into tunnel on right hand side
		<input type="checkbox"/> <b>RUS-BAS</b>	Rear cab upper storage 154 litres - 300 mm high
		<input type="checkbox"/> <b>RUS-HIG</b>	Rear cab upper storage 245 litres - 440 mm high
		<input type="checkbox"/> <b>TABLE</b>	Folding and height adjustable table - on lower bunk
		<input type="checkbox"/> <b>REF-ICPK</b>	Fridge: engine tunnel mounted preparation kit
		<input type="checkbox"/> <b>REFR-RUS</b>	Fridge: 28 litre rear upper wall mounted with dividers
		<input type="checkbox"/> <b>MICRO-PK</b>	Preparation kit for microwave oven (wiring)
		<input type="checkbox"/> <b>BOTH-D</b>	One bottle holder under dashboard centre section
		<input type="checkbox"/> <b>COFMA-PK</b>	Coffee maker, preparation kit.

Standard Equipment

Optional Equipment

For more detailed information about cab and powertrain equipment, please refer to separate specification sheets.

For all possible options and combinations of options please consult your Volvo sales contact who can create a specification to match your requirements using the Volvo Sales Support system (VSS).

The factory reserves the right to modify design and change equipment without previous notification. The specification can vary from country to country.

# MODEL RANGE

FMX11 6x4 Rigid - X-High T Ride - N3G Straight front axle FM 64 R1CTX

- **INLI-BAS** Interior white LED lights - basic
- **INLI-NL** Interior white and red night LED light with no dimmer
- **INLI-NLD** Interior white and red night LED light with dimmer
- **ARL-FLEX** Two flexible reading lamps (snake lamps)
- **RH-EE** Without roof hatch -Tinted glass emergency exit ONLY
- **RH-ETR** Glass roof & escape hatch - Electrically operated, tinted glass with rear opening
- **RH-MSR** Steel roof & escape hatch - Manually operated with rear opening
- **RH-MTR** Glass roof & escape hatch - Manually operated, tinted glass with rear opening
- **URH** Without roof hatch
- **SWIND-BS** Extra side window on both sides behind "B" pillar
- **SWIND-PS** Rear side window, passenger side
- **VANMIR** Vanity mirror in front shelf
- **AS-FUS** Extra shelf in front upper storage compartments
- **INFOT-PK** Preparation kit for the mounting of a flat screen TV in cab above the driver's door, includes bracket, electrical and speaker connections

## CAB EXTERIOR

- **PAICS-B** Basic cab paint - mirrors, sunvisor, instep and bumper supplied in natural finish - grey
- **GLAS-TIN** Tinted windows.
- **AWIND-RF** Rear window
- **DGLAS-L** Laminated door glass
- **LOCK-MAN** Manual door locking
- **LOCK-MRP** Manual door locking with internal remote control (from driver side) of passenger door
- **LOCK-REM** Central locking with remote control
- **BUMP-HD** Heavy duty front bumper
- **AUXFS** Lower swinging cab step
- **GUARD-EH** Engine guard to protect sump and engine hoses
- **BUGNET** Insect screen in front of radiator
- **CTILT-P-E** Electrically operated hydraulic cab tilt
- **CTILT-P-M** Manually operated hydraulic cab tilt
- **FCABS-A** Front cab suspension - Air
- **FCABS-M** Front cab suspension - Mechanical spring
- **RCABS-A** Rear cab suspension - Air
- **RCABS-M** Rear cab suspension - Mechanical spring
- **MIRCOMFX** Electrically heated and operated -FMX- main and wide-angle mirrors with manually adjusted passenger kerb mirror, to increase direct vision to the side the main mirrors have no cowlings
- **MIRSTDX** Electrically heated -FMX- main and wide-angle mirrors with manually adjusted passenger kerb mirror, to increase direct vision to the side the main mirrors have no cowlings
- **AMIR-F20** Auxiliary front view mirror with a 200mm radius
- **SUNV-H** External smoke grey sunvisor
- **AD-ROOF** Roof air deflector
- **AD-SIDEL** Side air deflector extension panels
- **AD-SIDES** Short cab side air deflector for rigid bodywork
- **HL-BAS2** Halogen H1 head lamps
- **HL-BASIC** Halogen H7 head lamps
- **HL-CLEAN** Head lamp cleaner - washer jets
- **HLP-ST** Headlamp protection
- **HL-ADJ** Headlight adjustment - Switch in cab
- **UDRIVL** Without auxiliary driving lights
- **ASL-RF2** Two Hella H11 70W spotlamps in sign box - only available with

■ Standard Equipment

□ Optional Equipment

For more detailed information about cab and powertrain equipment, please refer to separate specification sheets.

For all possible options and combinations of options please consult your Volvo sales contact who can create a specification to match your requirements using the Volvo Sales Support system (VSS).

The factory reserves the right to modify design and change equipment without previous notification. The specification can vary from country to country.

- **ASL-RFPK** the basic headlight and no lower driving lights. Preparation kit for two spotlamps in sign box
- **BEACO2F** Two front roof mounted amber beacon rotating warning lamps
- **BEACO2R** Two rear roof mounted (on accessory bracket) amber beacon flashing warning LED lamps
- **BEACON-P** Roof beacon wire preparation
- **BEACONA4** Four roof mounted (2 front/2 rear) amber beacon rotating warning lamps
- **CABPT-R1** Single outlet for roof mounted accessories
- **CABPT-R2** Twin outlets for roof mounted accessories.
- **SPOTP-F** Spotlamp preparation in front, max 280W
- **SPOTP-R** Spotlamp preparation on roof, max 280W
- **SPOTP-RF** Spotlamp preparation on cab roof and in cab front, max 2x280W
- **ROS-IL2** Preparation kit for illuminated roof sign with switch loose in cab, fit after registration
- **CSGN-FMX** "Volvo FMX" headboard logo
- **HORN-F1S** Single tone Jericho air horn chassis mounted
- **HORN-R2S** Two roof mounted air horns
- **ANT-CBR** Roof mounted antenna for CB radio, single aerial
- **ACCBP-AP** Front, middle & rear roof mounted accessory brackets
- **ACCBP-F** Front roof mounted accessory bracket
- **ACCBP-FM** Front & middle roof mounted accessory brackets
- **ACCBP-FR** Front & rear roof mounted accessory brackets
- **ACCBP-M** Middle roof mounted accessory bracket
- **ACCBP-R** Rear roof mounted accessory bracket
- **ACCBP-RM** Rear & middle roof mounted accessory brackets
- **REFS-TW** White cab conspicuity markings by packed in cab
- **REFS-TY** Yellow cab conspicuity markings by packed in cab

## SUPERSTRUCTURE PREPARATIONS

- **BP-MI02**
- **BP-TI03**
- **SRWL-PK** Wiring preparation for side & rear work/reverse lamps on side of chassis and a three-position switch, maximum 280W
- **SWL-2FW** Two H3 70W white front chassis mounted (LH/RH side) working lamps and a 2-position switch (On/Off)
- **SWL-2RW** Two H3 70W white rear chassis mounted (LH/RH side) working lamps and a 2-position switch (On/Off)
- **SWL-4W** 4 H3 70W white front (2) & rear (2) chassis mtd (LH/RH side) working lamps & 2-pos switch (On/Off)
- **SWL-PK** Wiring preparation for side work/reverse lamps on side of chassis and a three-position switch, maximum 280W
- **WLC-H2A** Two H3/70W working lamps with amber coloured lens high mounted back of cab
- **WLC-H2W** Two H3/70W white working lamps high mounted on the back of cab
- **WLC-PKCH** Preparation kit (cables and switch) for cab mounted chassis working lamp
- **WLC-PKH** Preparation kit, cables and switch for high mounted working lamps back of cab
- **WLC-PKL** Preparation kit, cables and switch for low mounted working lamps back of cab
- **WLC-PKLH** Preparation kit - cables and switch for low and high mounted working lamps back of cab.
- **ECBB-BAS** Body builder electrical centre without body builder module
- **ECBB-HIG** Body builder electrical centre with body builder module
- **BBCHAS1** One 7-pole connector for Body builder interface
- **BBCHAS3** Three 7-pole connectors for Body builder interface
- **BEPR-T2** Body builder electrical software preparation for tipper with remote control
- **EXSTER** External steering control, with VDS and bodybuilder module
- **TD-BAS** Trailer detection WITHOUT LED sensing
- **TD-LED** Trailer detection with LED sensing
- **FRFS-BS** Frame rail free space on both sides to give space for crane

# MODEL RANGE

FMX11 6x4 Rigid - X-High T Ride - N3G Straight front axle FM 64 R1CTX

---

- legs or other equipment.
- FBA-BTF** Lower front body attachments for torsionally flexible - platform body
- FBA-BTSF** Lower front body attachments for torsionally semi-flexible body - box or curtainsider
- HBA-FSFB** Holes for body attachments - flexible/semi-flexible body
- HBA-SB** Holes for body attachments - stiff body
- RBA-T2** Lower rear body attachments for helper frame
- CRANEPK1** Crane plates mounted to frame, for cranes up to 10 tonne metre capacity
- CRANEPK2** Crane plates mounted to frame, for cranes up to 20 tonne metre capacity
- CRANEPK4** Crane plates mounted to frame, for cranes up to 40 tonne metre capacity
- AUXL-SPK** Electrical preparation kit - wiring and switch for snow plough lights
- TAILPRE2** Tail lift preparation kit, wireless remote operation
- TAILPREP** Taillift preparation kit - cab switch and warning in driver display
- AESW2** Two Body builder bistable electrical switches (marked AUX1 / AUX2)
- AESW2PK** 2 Body builder bistable el.switches (marked AUX1/AUX2) and prep. for 4 more switches
- AUXSW-4** Wiring for 4 extra switches (from Body builder electrical centre to switch positions)

## DELIVERY SERVICES

- TGW-4GWL** GSM/GPRS/4G modem, LTE & WLAN for telematics gateway
- FMS-PK** Fleet Management System gateway

**VOLVO**

Volvo Truck Corporation  
volvotrucks.com