

MODEL RANGE

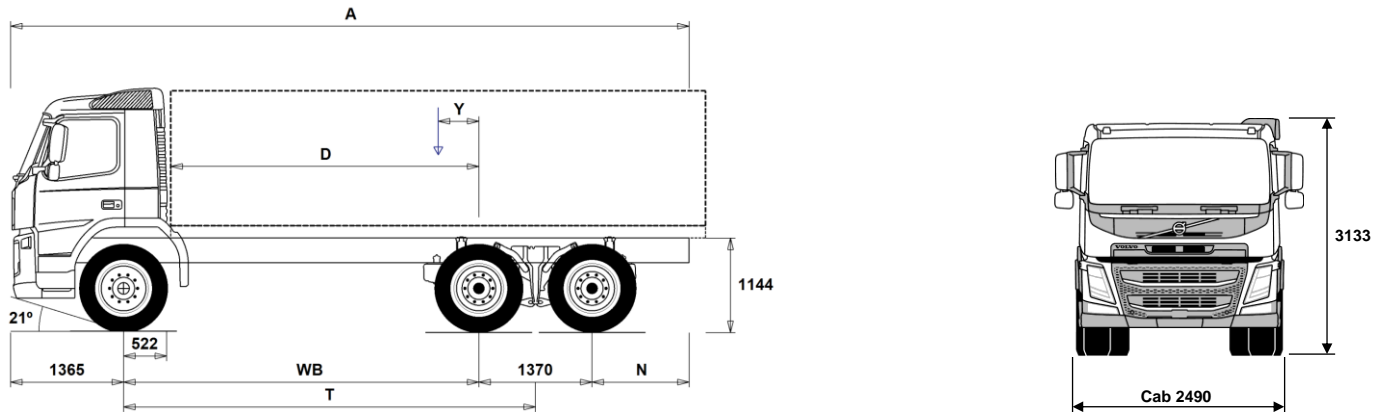

Volvo Trucks. Driving Progress

FM 11 6x4 Rigid - X-High Rear Air Suspension - N3G Straight front axle FM 64 R1CA



Chassis Dimensions [mm]

WB Wheelbase	3400	3700	3900	4300	4600
A Overall Chassis Length	7310	7610	7810	8210	8510
D Center of rear axle to front of body	2828	3128	3328	3728	4028
N Rear Overhang (Min.)	825	825	825	825	825
N Rear Overhang (Max.)	1175	1175	1175	1175	1175
T Theoretical Wheelbase	4085	4385	4585	4985	5285
Y Center of Gravity for Payload (Min.)	-74	-34	-8	43	82
Y Center of Gravity for Payload (Max.)	152	209	246	321	377

Chassis Weights [kg]

Front Axle	4295	4320	4340	4375	4400
Rear Bogie	3635	3645	3650	3670	3685
Kerb Weight	7930	7965	7990	8045	8085
Payload (including body, driver, fuel, etc.)	18070	18035	18010	17955	17915

Turning Diameter [mm]

Turning Circle Diameter Kerb to Kerb	14500	15500	16100	17300	18200
Turning Circle Diameter Wall to Wall	16000	16900	17500	18700	19700

Plated Weights [kg]

	Plated	Design
Gross Vehicle Weight	26000	29000
Gross Combination Weight	44000	44000
Front Axle	8000	8000
Rear Bogie	19000	21000

Important Notes

Chassis Dimensions

Cab Height: +416 mm for CAB-HSLP, -169 mm for CAB-LSLP.
Front Axle to Back of Cab: +424 mm for CAB-HSLP and CAB-SLP, +418 mm for CAB-LSLP.

D-measure includes a front clearance of 50 mm and for rigid trucks also a subframe of 100 mm.

Height can vary ± 20 mm for leaf and ± 10 mm for air suspension.

All dimensions are for unladen chassis and any tag axles down.

Rear overhang used for vehicle weight calculation is the maximum rear overhang (N Max.) for selected wheelbase.

Weight and dimensions are based upon the following tyres:

Front Axle Tyres: 315/80R22.5
Drive Axle Tyres: 315/80R22.5

Chassis weight includes oil, water, AdBlue, 0 litres fuel and without driver. Kerb weight can vary $\pm 3\%$.

Turning diameters are theoretically calculated.

Legal weights can differ from country to country.

For more detailed weight information, including optional equipment weights, ask your Volvo sales contact to enter your specification into the Volvo Weight Information system (WIS).

Do NOT use this drawing for bodybuilding. Refer to Volvo Bodybuilder Instructions and chassis assembly drawing FM64R1CA.

MODEL RANGE

FM 11 6x4 Rigid - X-High Rear Air Suspension - N3G Straight front axle FM 64 R1CA

TRUCK USE

- **RC-ROUGH** Operating class on/off road
- **GARB-PRE** Garbage preparation
- **TIPP-PRE** Tipper vehicle preparation

CORE COMPONENTS

- **CHH-XHIG** Chassis height X-High - For a specific loading height always check the unique BEP chassis drawing
- **RADD-G2** Rear air suspension, 2 axles - 2 driven, high ground clearance
- **FM-DAY** Day cab - with steel safety cage design
Designed and built to Swedish impact and ECE R29 regulations
- **FM-HSLP** Globetrotter cab - with steel safety cage design
Designed and built to Swedish impact and ECE R29 regulations
- **FM-LSLP** Low sleeper cab - with steel safety cage design
Designed and built to Swedish impact and ECE R29 regulations
- **FM-SLP** Sleeper cab - with steel safety cage design
Designed and built to Swedish impact and ECE R29 regulations
- **EU6SCR** Emission level - Euro 6
- **D11K330** D11K330 10.8 litre engine developing 330hp at 16-1900rpm.
Peak torque 1600Nm at 950-1400rpm.
- **D11K380** D11K380 10.8 litre engine developing 380hp at 17-1900rpm.
Peak torque 1800Nm at 950-1400rpm.
- **D11K430** D11K430 10.8 litre engine developing 430hp at 17-1800rpm.
Peak torque 2050Nm at 1058-1400rpm.
- **D11K460** D11K460 10.8 litre engine developing 450hp at 16-1800rpm.
Peak torque 2200Nm at 1050-1400rpm.
- **EBR-EPG** Exhaust brake controlled by steering column switch
- **EBR-EPGC** Exhaust pressure governor for I shift gearbox
- **EBR-VEB** Volvo engine brake and exhaust pressure governor retardation 300kW
- **AT2612F** AT2612F 12-speed "I-shift" automated mechanical gearbox suitable for gross train weights up to 60tonne only refer to sales engineering when used in conjunction with a PTO
- **ATO2612F** ATO2612F 12-speed "I-shift" overdrive automated mechanical gearbox suitable for gross train weights up to 60tonne refer to sales engineering when used in conjunction with a PTO
- **PT2106** Powertronic automatic 6-speed gearbox, max. engine torque 2100 Nm, max. permitted GCW 100000 kg
- **TAAXLIFT** Rear axle lift for double drive bogie
CONTACT VOLVO SALES ENGINEERING to check lift capability
- **RTH2610F** RTH2610F hub reduction tandem 26tonne drive axles, GCW 100 tonnes with differential and cross locks*
* Cross locks replaced by a dog clutch if tandem axle lift is specified
- **RTS2310A** RTS2310A single reduction tandem 23tonne drive axles with differential and cross locks* - design GCW 100tonnes.
* Cross locks replaced by a dog clutch if tandem axle lift is specified.
- **RTS2370A** RTS2370A single reduction tandem 23tonne drive axles with differential and cross locks* - design GCW 70tonnes.
* Cross locks replaced by a dog clutch if tandem axle lift is specified.

PACKAGES

- **DRIVEFM** Cab Package: Drive
- **DRIVEFM+** Cab Package: Drive +
- **BEDFM** One bed resting package
- **AUDHIG** High Power Audio system: RDS radio with CD player - also playing MP3/WMA files from CD -, with integrated bluetooth phone and USB/Line inputs. FM/AM antenna, speakers in dashboard, doors, and sleeping compartment.

- Standard Equipment
- Optional Equipment

For more detailed information about cab and powertrain equipment, please refer to separate specification sheets.

For all possible options and combinations of options please consult your Volvo sales contact who can create a specification to match your requirements using the Volvo Sales Support system (VSS).

The factory reserves the right to modify design and change equipment without previous notification. The specification can vary from country to country.

- **MEDIA** AM/FM Bluetooth radio without CD player.
USB and Aux line inputs.
Speakers in dashboard, doors, and sleeping compartment.
7" touch screen with personal apps.
- **MEDIADF** AM/FM Bluetooth radio without CD player.
USB and Aux line inputs.
Speakers in dashboard, doors, and sleeping compartment.
7" touch screen with personal and professional apps.
Truck based satellite navigation (live updates not included)
AM/FM Bluetooth radio without CD player.
USB and Aux line inputs.
Speakers in dashboard, doors, and sleeping compartment.
7" touch screen with personal and professional apps.
Truck based satellite navigation (live updates not included)
Dynafleet vehicle on-board data display with office internet support.
- **MEDIANAV** AM/FM Bluetooth radio without CD player.
USB and Aux line inputs.
Speakers in dashboard, doors, and sleeping compartment.
7" touch screen with personal and professional apps.
Truck based satellite navigation (live updates not included)
- **MEDIANDF** AM/FM Bluetooth radio without CD player.
USB and Aux line inputs.
Speakers in dashboard, doors, and sleeping compartment.
7" touch screen with personal and professional apps.
Truck based satellite navigation (live updates not included)
Dynafleet vehicle on-board data display with office internet support.
- **VISI15** Visibility Package
- **VISI15+** Visibility Plus Package

CHASSIS

- **FST-PAR3** Front suspension type - 3 leaf parabolic springs
- **FSLB-BAS** Front suspension levelling - basic stroke
- **FSLB-HI** Front suspension levelling - high stroke for demount operations - check with bodybuilder
- **FAL10.0** Front axle design capacity 10 tonnes - Ensure that you have checked the tyre load index
- **FAL8.0** Front axle design capacity 8.0 tonnes - Ensure that you have checked the tyre load index
- **FAL9.0** Front axle design capacity 9.0 tonnes - Ensure that you have checked the tyre load index
- **FSM-LUB** Lubricated rear shackles on front suspension pins and bushings
- **FSTAB** Front anti-roll bar
- **FSTAB2** Front anti-roll bar medium stiffness
- **FSTAB3** Front stiff anti-roll bar
- **RAL21** Rear bogie design capacity 21 tonnes
- **RAL23** Rear bogie design capacity 23 tonnes
- **RAL26** Rear bogie design capacity 26 tonnes
- **RSTAB3** Rear stiff anti-roll bar
- **RALIM105** Rear axle load limiter, 10.5 tonnes
- **RALIM115** Rear axle load limiter, 11.5 tonnes
- **RALIM13** Rear axle load limiter, 13 tonnes
- **RALIM95** Rear axle load limiter, 9.5 tonnes
- **ASF-DL1** Air suspension with 1 driving level
- **ASF-DL3** Air suspension with 3 driving levels
- **ACTST-TO** Volvo Dynamic Steering (VDS) with with extra electronic pump and torque overlay
- **ASFE-BAS** Active steering feature - Basic - Volvo Dynamic Steering only
- **ASFE-PS** Active steering feature - Volvo Dynamic Steering with personal settings
- **PSS-SING** Single power steering system
- **PSP-FIX** Power steering pump with fixed displacement
- **PSP-VAR** Power steering pump with variable displacement
- **EBS-MED** EBS medium package including "hill" hold function
- **AUXPARK** Additional spring parking brakes
- **FBREG-E** Front regulating brake valve, EBS
- **SUSPL-EC** Remote electronic control on wander-lead for air suspension levelling
- **FRAME266** Frame rail section external height 266 mm

MODEL RANGE

FM 11 6x4 Rigid - X-High Rear Air Suspension - N3G Straight front axle FM 64 R1CA

<input checked="" type="checkbox"/> FRAME300	Frame rail section external height 300 mm	<input type="checkbox"/> RFEC-L	Rear frame end, lower flange cut for centre axle drawbar.
<input type="checkbox"/> FST7070	Frame thickness - web and flange 7.0mm	<input checked="" type="checkbox"/> RFEC-S	Rear frame end, straight cut for regular platform applications
<input type="checkbox"/> FST8080	Frame thickness - web and flange 8.0mm	<input type="checkbox"/> RFEC-U	Rear frame end, upper cut for tipper applications.
<input type="checkbox"/> FIL-EEEB	Inner liner from end of engine to end of bogie	<input type="checkbox"/> C-RI4040	Towing coupling, Ringfeder 4040 G-150
<input type="checkbox"/> FIL-EEEF	Inner liner from end of engine to end of frame	<input type="checkbox"/> C-RI5055	Towing coupling, Ringfeder 5055 G-150
<input type="checkbox"/> FIL-FBEB	Inner liner over rear bogie	<input type="checkbox"/> C-RO400G	Towing coupling, Rockinger 400 G-150 for 40mm eyes
<input type="checkbox"/> FIL-FBEF	Inner liner from front of bogie to end of frame	<input type="checkbox"/> C-RO50	Rockinger RO 50 50mm for centre axle trailer
<input checked="" type="checkbox"/> FIL-TXEB	Inner liner from gearbox member to end of bogie	<input type="checkbox"/> TOWR-ONE	Towing hitch attached to rear crossmember
<input type="checkbox"/> FIL-TXEF	Inner liner from gearbox member to end of frame	<input checked="" type="checkbox"/> TREL-PK	Trailer electrical preparation kit - chassis/cab wiring
<input checked="" type="checkbox"/> BBOX-L	Battery box located on left hand side	<input type="checkbox"/> TREL14	Single 14 pole electrical trailer connector
<input type="checkbox"/> 2BAT210B	2 x 210 Ah capacity Gel batteries	<input type="checkbox"/> TREL15	Single 15 pole electrical trailer connector - ADR certified
<input checked="" type="checkbox"/> 2BATT170	2 x 170 Ah capacity batteries	<input type="checkbox"/> TREL7	7 pole - 24N trailer electrical suzie
<input type="checkbox"/> 2BATT225	2 x 225 Ah capacity batteries	<input type="checkbox"/> TREL7-7	24N and 24S trailer electrical suzies
<input checked="" type="checkbox"/> BATTAMP	Battery voltage and ampere gauge	<input type="checkbox"/> TBC-DUO	Duomatic type air line connectors
<input type="checkbox"/> BATTIND	Battery charge indication	<input type="checkbox"/> TBC-EC	Palm coupling type air line connectors
<input type="checkbox"/> ADR2	ADR package for transportation of dangerous goods on road (Note does NOT include safe loading pass package if required this is quoted seperately)	<input type="checkbox"/> TRBR-HCF	Full pressure hand controlled trailer brake
<input type="checkbox"/> MSWI-A	Main switch - ADR switch circuit shut down	<input type="checkbox"/> TRBR-STA	Stationary trailer brake control
<input checked="" type="checkbox"/> MSWI-C	Main switch - Chassis mounted toggle switch by battery box	<input type="checkbox"/> TRB-STRE	Stretch Brake - Automatic low speed trailer brake activation to avoid jack-knifing and improve steerability
<input type="checkbox"/> MSWI-R	Main switch - Key fob operated remote controlled	<input type="checkbox"/> RUP-FOSL	Folding & sliding EC approved aluminium rear underrun
<input checked="" type="checkbox"/> R315A56	Right aluminium 560 mm D-shaped fuel tank, 315 litres volume Min volume 255l Max volume 885l	<input type="checkbox"/> RFEND-B	Three piece EC approved rear mud wings and spray flaps
<input checked="" type="checkbox"/> UL-FUEL	Without left fuel tank Min volume 160l Max volume 730l	<input type="checkbox"/> RFEND-T	Rear mud wings, transport mounted
<input type="checkbox"/> ADTP-L	AdBlue tank on left hand side	<input type="checkbox"/> RFH-BAS	Basic rear wing height
<input checked="" type="checkbox"/> ADTP-R	AdBlue tank on right hand side	<input type="checkbox"/> RFH-HIG	High rear wing height - higher wing tops
<input checked="" type="checkbox"/> ADB048	AdBlue tank usable volume 48 litres	<input type="checkbox"/> RFH-LOW	Lower rear wing height - shallower wing tops
<input checked="" type="checkbox"/> ADB064	AdBlue tank usable volume 64 litres	<input type="checkbox"/> AUXATNK	Auxiliary airtank
<input type="checkbox"/> ADB068	AdBlue tank usable volume 68 litres	<input type="checkbox"/> ATANK-AL	Aluminium air tanks
<input checked="" type="checkbox"/> ADB090	AdBlue tank usable volume 90 litres	<input checked="" type="checkbox"/> ATANK-ST	Steel air tanks
<input type="checkbox"/> ADB100	AdBlue tank usable volume 100 litres	<input type="checkbox"/> RESTS-W	White conspicuity markings on chassis - sideguards, toolbox and rear overhang
<input checked="" type="checkbox"/> FCAP-L	Locking fuel filler cap	<input type="checkbox"/> REST-RUP	
<input checked="" type="checkbox"/> FUFF-AS	Fuel filling anti-spillage device	<input checked="" type="checkbox"/> TL-LED	Rear lights LED
<input type="checkbox"/> FUFF-ATS	Fuel filling anti-theft and anti-spillage devices	<input type="checkbox"/> BLIGHT-E	Emergency brake light
<input type="checkbox"/> ESH-LEFT	Horizontal silencer, left exhaust outlet	WHEELS & TYRES	
<input checked="" type="checkbox"/> ESH-REAR	Horizontal silencer, rear exhaust outlet	<input type="checkbox"/> RT-AL	Alcoa brushed aluminium rims with standard holes for long stud fixing on all axles
<input type="checkbox"/> ESH-RIGH	Horizontal silencer, right exhaust outlet	<input type="checkbox"/> RT-ALDP	Alcoa Dura-Bright EVO aluminium rims with standard holes long stud fixing on all axles, requires cleaning with a ph neutral solution - washing up liquid.
<input type="checkbox"/> ESH-VERT	Horizontal silencer, vertical exhaust outlet	<input type="checkbox"/> RT-ALDPD	Alcoa Dura-Bright EVO aluminium rims with countersunk holes for short stud fixing on all axles, requires cleaning with a ph neutral solution - washing up liquid.
<input type="checkbox"/> EXST-SSP	Stainless steel exhaust stack - NOT polished	<input type="checkbox"/> RT-ALDU	Alcoa brushed aluminium rims with countersunk holes for short stud fixing on all axles
<input type="checkbox"/> EXST-ST	Steel exhaust stack	<input type="checkbox"/> RT-SPOKE	Spoke rims on all axles
<input type="checkbox"/> HS-NAR	Narrow heat shield	<input checked="" type="checkbox"/> RT-STEEL	Steel rims on all axles
<input type="checkbox"/> WHC-FIX2	Two fixed wheel chocks	<input type="checkbox"/> WCAP	Aerodynamic hub caps
<input type="checkbox"/> WHC-FOL2	Two foldable wheel chocks	<input type="checkbox"/> BRREC001	Bridgestone ECOPIA H - Energy rating C
<input type="checkbox"/> WHCP-F	Wheel chock(s) stored in the front part of the vehicle	<input type="checkbox"/> BRREC002	Bridgestone Ecopia H 002 Evo - Tyre recommendation 2
<input type="checkbox"/> WHCP-M	Wheel chock(s) stored in the middle part of the vehicle	<input type="checkbox"/> COREC002	Continental ECOPLUS HS3/HD3 - Energy rating B or C depending on size
<input type="checkbox"/> WHCP-R	Wheel chock(s) stored in the rear part of the vehicle	<input type="checkbox"/> GYREC001	Goodyear FUELMAX S/HL/D - Energy rating B or C depending on size
<input type="checkbox"/> WHCP-T	Transport mounted wheel chock(s) stored in cab outer luggage locker	<input type="checkbox"/> GYREC003	Goodyear FUELMAX S/(O)/D - Fuel tyre Recommendation 3
<input type="checkbox"/> TB-L80	Toolbox 800 mm, left side	<input type="checkbox"/> HAREC001	Hankook AL10+ E-Cube Max Long Haul Tyre - Energy rating B
<input type="checkbox"/> TB-R80	Toolbox 800 mm, right side	<input type="checkbox"/> HAREC002	Hankook AL10+ E-Cube Long Haul Tyre - Energy rating B with wide single
<input type="checkbox"/> CHAIN-S	Snow chains	<input type="checkbox"/> MIREC002	Michelin XZA2/X-LINE Energy - Fuel tyre Recommendation 2
<input type="checkbox"/> HOOK-SC	Snow chain hooks	<input type="checkbox"/> MIREC003	Michelin X-LINE Energy - Fuel tyre Recommendation 3
<input checked="" type="checkbox"/> TOWF-NO1	One front towing device	<input type="checkbox"/> MIREC004	Michelin X Line Energy F/D2 - Energy rating A
<input type="checkbox"/> TOWF-NO2	Two front towing devices	<input type="checkbox"/> PIREC001	Pirelli FH:01 Proway - Long Haul Tyre - Energy rating B
<input type="checkbox"/> TOWMBR1	Towing member, high mounted in centre of frame, D = 190	<input type="checkbox"/> PIREC002	Pirelli FH:01 II Long Haul Tyre - Energy rating B with wide single
<input type="checkbox"/> TOWMBRL1	Towing member, low mounted under the frame	<input type="checkbox"/> SPWT-D	Spare wheel & tyre with rear tyre pattern
<input type="checkbox"/> TOWMBRM	Towing member, medium mounted in line with frame lower flange		

Standard Equipment

Optional Equipment

For more detailed information about cab and powertrain equipment, please refer to separate specification sheets.

For all possible options and combinations of options please consult your Volvo sales contact who can create a specification to match your requirements using the Volvo Sales Support system (VSS).

The factory reserves the right to modify design and change equipment without previous notification. The specification can vary from country to country.

MODEL RANGE

FM 11 6x4 Rigid - X-High Rear Air Suspension - N3G Straight front axle FM 64 R1CA

- SPWT-F** Spare wheel & tyre with front tyre pattern
 - SWCP-LF** Spare wheel carrier on left side of chassis ahead of rear axle
 - SWCP-R** Rear mounted spare wheel carrier
 - SWCP-T** Spare wheel supplied temporarily strapped to chassis
 - SWCP-TP** Temporary spare wheel carrier on top of chassis frame
 - JACK-12T** 12 tonne bottle jack
 - JACK-15T** 15 tonne bottle jack
 - JACK-20T** 20 tonne bottle jack
 - TOOL-BAS** Basic Toolkit
 - TOOLKIT** Complete tool kit
 - INFLAHOS** Tyre inflation hose
 - GAUGE-TP** Tyre pressure gauge
- ### DRIVELINE EQUIPMENT
- TRAP-HD** Reinforced gearbox application
 - TP-CON** Construction Package
 - TP-DIST** Distribution Package
 - TP-HD** I-shift software - Heavy duty for high GCW
Special conditions apply consult Sales Engineering
 - TP-LONG** Long Haul Package
 - AMSO-AUT** Enhanced I-shift software with manual shift available in auto mode and kickdown facility on accelerator pedal
 - AVO-ENH** Enhanced software for off road driveability and starting
 - APF-ENH** I-shift enhanced PTO functions
 - RET-TH** Gearbox mounted retarder
 - RET-TPT** Hydraulic Retarder for Powertronic gearbox
 - TC-HWO** Automatic gearbox oil cooler - water to oil
 - TC-MAOH2** Extra high performance transmission oil cooler - air to oil with front mounted radiator
 - TC-MWO** Basic transmission oil cooler - water to oil
 - 2COM1100** Two cylinder, air compressor, 1100 litres per minute
 - 2COMP900** Two cylinder, air compressor, 900 litres per minute
 - CLU-AIRC** Clutchable air compressor
 - AIRIN-HI** Roof mounted air intake behind cab on left hand side
 - AIRIN-LO** Low level air intake behind cab on left hand side
 - ACL1ST-S** Two stage air filter
 - 24AL110B** 110 amp alternator
 - 24AL120B** 120 amp alternator
 - 24AL150B** 150 amp alternator
 - CCV-C** Closed crankcase engine ventilation
 - CCV-OX** Closed crankcase ventilation for cold markets
 - PRIM-EL** Electrical priming pump
 - PRIM-MAN** Manual priming pump
 - FUEQ-EH** Fuel line electric heater
 - AF-R** Hot fuel recirculation heated fuel filter
 - FUEFE2LW** Large engine mounted dual fuel filter with water separator
 - FUEFE2SW** Small engine mounted dual fuel filter with water separator
 - EST-AID** Air inlet manifold starting heater element
 - 220EBH15** 220V/1.5Kw electric engine block heater
 - PTER-100** Rear engine mounted power-take-off with DIN 100 / ISO 7646 flange
 - PTER-DIN** Rear engine mounted PTO with DIN5462 (female) splined shaft for a close coupled pump.
Models with 3 steering axles will use this to drive the steering pump (AUXPSP)
 - PTER1400** Rear engine mounted power-take-off with SAE 1410 flange
 - HPE-F101** Parker F1-101, engine mounted, fixed displacement, single flow, engine mounted hydraulic pump
 - HPE-F41** Parker F1-41, engine mounted, fixed displacement, single flow, engine mounted hydraulic pump
 - HPE-F51** Parker F1-51, engine mounted, fixed displacement, single flow, engine mounted hydraulic pump
 - HPE-F61** Parker F1-61, engine mounted, fixed displacement, single flow, engine mounted hydraulic pump
 - HPE-F81** Parker F1-81, engine mounted, fixed displacement, single flow, engine mounted hydraulic pump
 - HPE-T53** Parker F2-53/53, engine mounted, Fixed displacement, Twin flow engine mounted hydraulic pump
 - HPE-T70** Parker F2-70/35, engine mounted, Fixed displacement, Twin flow engine mounted hydraulic pump
 - HPE-V45** Parker VP1-45, variable displacement, single flow, engine mounted hydraulic pump
 - HPE-V75** Parker VP1-75, variable displacement, single flow, engine mounted hydraulic pump
 - PTPT-D** Powertronic PTO, 1 front/upper DIN connection for plug-in pump (max. 850 Nm)
 - PTPT-F** Powertronic PTO, 1 front/upper rear facing SAE flange conn. for prop shaft (max.850 Nm)
 - PTR-D** Gearbox PTO for plug-in pump, 0.71xeng speed
 - PTR-DH** Gearbox driven high speed PTO for one plug-in hydraulic pump
 - PTR-DM** Gearbox driven medium speed PTO for one plug-in hydraulic pump
 - PTR-F** Gearbox driven PTO with rear flange connection
 - PTR-FH** Gearbox driven high speed PTO with SAE drive flange
 - PTR-FL** Gearbox driven low speed PTO with SAE drive flange
 - PTRD-D** Gearbox driven HIGH SPEED PTO for two plug-in hydraulic pumps
 - PTRD-D1** PTRD-D1 Gearbox driven HIGH SPEED PTO (1 SAE flange & 1 plug-in hydraulic pump)
 - PTRD-D2** Gearbox driven HIGH SPEED PTO (2 SAE flanges & 1 plug-in hyd pump)
 - PTRD-F** PTO with 1 DIN + 1 flange connection rear, manual gearbox
 - HPG-F101** Parker F1-101 gearbox mounted, fixed displacement, single flow, hydraulic pump
 - HPG-F41** Parker F1-41 gearbox mounted, fixed displacement, single flow, hydraulic pump
 - HPG-F51** Parker F1-51 gearbox mounted, fixed displacement, single flow, hydraulic pump
 - HPG-F61** Parker F1-61 gearbox mounted, fixed displacement, single flow, hydraulic pump
 - HPG-F81** Parker F1-81 gearbox mounted, fixed displacement, single flow, hydraulic pump
 - EIDLESD** Engine idle shut down
 - DTRI-PER** Dashboard in darker peregrine greyish brown. Steering wheel grey and door panels in light beige for FH and black for FH16.
 - STWPOS-R** RIGHT HAND DRIVE
 - STWM-LE** Leather steering wheel
 - STGW-AD2** Adjustable steering wheel with neck tilt
 - STGW-ADJ** Adjustable steering wheel
 - AIRBAG** SRS Driver's air bag
 - DRC-AMII** DPF Regeneration control switch - for manual and switching off regeneration
 - 1DAYDIG2** Continental VDO DTCO 4.0 smart tachograph
This tachograph can ONLY offer remote download if the option of Dynafleet or an FMS gateway has been specified with this order.
 - 1DAYDIGP** Continental VDO DTCO 3.0 digital tachograph
For vehicles with long lead time - this includes prep kit for the retrofit of DTCO 4.0 tachograph.
For updating to new legal demand for trick registration from 15th June 2019.
This tachograph can ONLY offer remote download if the option of Dynafleet or an FMS gateway has been specified with this order.
 - ARSL** Additional road speed limit - switch in dashboard
 - SPEED-DU** Dual speed limiter

■ Standard Equipment

□ Optional Equipment

For more detailed information about cab and powertrain equipment, please refer to separate specification sheets.

For all possible options and combinations of options please consult your Volvo sales contact who can create a specification to match your requirements using the Volvo Sales Support system (VSS).

The factory reserves the right to modify design and change equipment without previous notification. The specification can vary from country to country.

MODEL RANGE

FM 11 6x4 Rigid - X-High Rear Air Suspension - N3G Straight front axle FM 64 R1CA

<input type="checkbox"/> CRUIS-E	Eco cruise control (with eco-roll and I-cruise, controls in steering wheel)	vinyl bolster with red vinyl side insert. Interior trim: Raven black bunk and curtains & grey vinyl side walls
<input checked="" type="checkbox"/> CRUISEC	Cruise control, standard	Seats: Blue soft textile insert, black vinyl bolster. Interior trim: Raven black bunk and curtains & blue textile side walls
<input checked="" type="checkbox"/> ESP-BAS1	Electronic Stability Control	<input type="checkbox"/> UPHTRI12
<input type="checkbox"/> ESPC-RO	ESP (Electronic Stability Program) functionality control - Reduced / Off	<input type="checkbox"/> UPHTRI13
<input type="checkbox"/> HWSS-ACB	Adaptive cruise control ACC with forward collision warning and AEBs advanced emergency brake system	<input type="checkbox"/> UPHTRI14
<input type="checkbox"/> HWSS-FCB	Forward collision warning with AEBs advanced emergency brake system	<input checked="" type="checkbox"/> DST-CF4
<input type="checkbox"/> LSS-DW	Lane departure-warning system	<input type="checkbox"/> DST-CF5
<input type="checkbox"/> LCS	Lane change support	<input type="checkbox"/> DST-CF6
<input type="checkbox"/> DAS-W	Driver Alert Support system	<input type="checkbox"/> SBD-RED
<input type="checkbox"/> RSENS-W	Rain sensing windscreen wipers	<input type="checkbox"/> SBPRE-DS
<input type="checkbox"/> CU-ECC	Electrically controlled air conditioning with sun sensor	<input checked="" type="checkbox"/> PST-BAS1
<input type="checkbox"/> CU-ECC2	Electrically controlled air conditioning with sun sensor, mist sensor, air quality sensor and carbon filter	<input type="checkbox"/> PST-BENC
<input checked="" type="checkbox"/> CU-MCC	Climate unit with manual controlled air conditioning	<input type="checkbox"/> PST-CF4
<input checked="" type="checkbox"/> IMMOBIL	Thatcham H2 approved immobiliser	<input type="checkbox"/> PST-CF5
<input type="checkbox"/> ALARM-B	Thatcham H1 approved vehicle alarm - Cab only	<input type="checkbox"/> PST-STD2
<input type="checkbox"/> ALARM-E	Enhanced vehicle alarm - Thatcham H1 approved - Cab plus external sensor for body/trailer	<input type="checkbox"/> PST-STD4
<input type="checkbox"/> ALCOLOCK	Alcolock	<input type="checkbox"/> SBPRE-PS
<input type="checkbox"/> BUPMON	Back up monitor with built in 7" screen on dash and one colour camera supplied loose for fitment by bodybuilder. Can accommodate up to 4 cameras for TFL Safe Scheme, CLOCS and FORS.	<input type="checkbox"/> ARM-DBPS
<input type="checkbox"/> PHONE-PK	Telephone preparation kit (antenna, antenna attachm. cable incl.)	<input type="checkbox"/> ARMRE-BB
<input type="checkbox"/> WLIFT-AD	Electrical window lift, automatic up/down driver side	<input type="checkbox"/> ARMRE-DB
<input checked="" type="checkbox"/> WLIFT-EB	Electrical window lift	<input type="checkbox"/> ARMRE-PB
<input type="checkbox"/> WLIFT-ME	Mechanical window lift	<input type="checkbox"/> ARMRE-PS
<input type="checkbox"/> ISUNS-BS	Side interior sun visor on both sides	<input type="checkbox"/> ARU-BAS
<input checked="" type="checkbox"/> ISUNS-DS	Driver's side interior sun visor	<input type="checkbox"/> ARU-LEA
<input checked="" type="checkbox"/> ISUNF-B	Interior front sun visor without mirror	<input checked="" type="checkbox"/> FMAT-RUB
<input type="checkbox"/> ISUNF-MD	Interior front sun visor with mirror on driver side	<input type="checkbox"/> FMAT-TX2
<input type="checkbox"/> ISUNF-RE	Electrically operated textile interior sun blind	<input type="checkbox"/> LBK-RES
<input type="checkbox"/> ISUNF-RM	Manually operated textile interior sun blind	<input type="checkbox"/> LBK70
<input type="checkbox"/> ADFS	Two extra DIN slots in front shelf - can be fitted with card or drawer available as an accessory	<input checked="" type="checkbox"/> ULBK
<input checked="" type="checkbox"/> BUPALARM	Reverse alarm	<input type="checkbox"/> MATL-FI
<input type="checkbox"/> RTOLL-PK	Road toll PREPARATION kit for trucks operating with "Toll Collect" in Germany	<input type="checkbox"/> MATL-SF
<input type="checkbox"/> LOADIND	Load indicator with central dashboard display	<input type="checkbox"/> MATL-SO
<input type="checkbox"/> REMC-MF	Multi-functio wireless remote control	<input type="checkbox"/> OLMAT-BA
<input type="checkbox"/> FIREXT3S	3kg fire extinguisher mounted on seat base	<input type="checkbox"/> OLMAT-PR
<input type="checkbox"/> WARNVEST	High visibility warning vest - no sleeves	<input type="checkbox"/> TBK60F
<input type="checkbox"/> AIDKIT	First aid kit	<input type="checkbox"/> TBK70F
<input type="checkbox"/> AIDKIT1B	First aid kit	<input type="checkbox"/> PH-CAB2
<input type="checkbox"/> WARNLAMP	Portable warning lamp	<input type="checkbox"/> PH-ENGCA
<input type="checkbox"/> LAMP-IN	Inspection lamp	<input type="checkbox"/> PH-SS
<input type="checkbox"/> BULBKIT	Bulb and fuse kit	<input type="checkbox"/> SLCP-BAS
<input type="checkbox"/> WRITEPAD	Writing pad	<input type="checkbox"/> SAFE
<input type="checkbox"/> UPHTRI10	Seats: Black embossed textile insert with light grey sides, black vinyl side bolster with blue vinyl side insert. Interior trim: Raven black bunk and curtains & blue textile side walls	<input type="checkbox"/> ETSB-F
<input type="checkbox"/> UPHTRI11	Seats: Light grey embossed textile insert, black raven metallic	<input type="checkbox"/> ETSB-FR
		<input type="checkbox"/> ETSB-FRS
		<input type="checkbox"/> ETSB-FS
		<input type="checkbox"/> ETSB-R

Standard Equipment

Optional Equipment

For more detailed information about cab and powertrain equipment, please refer to separate specification sheets.

For all possible options and combinations of options please consult your Volvo sales contact who can create a specification to match your requirements using the Volvo Sales Support system (VSS).

The factory reserves the right to modify design and change equipment without previous notification.
The specification can vary from country to country.

MODEL RANGE

FM 11 6x4 Rigid - X-High Rear Air Suspension - N3G Straight front axle FM 64 R1CA

- ETSB-RS** Storage on engine tunnel - at rear cab wall and storage recessed into tunnel on right hand side
 - ETSB-S** Storage on engine tunnel - recessed into tunnel on right hand side
 - RUS-BAS** Rear cab upper storage 154 litres - 300 mm high
 - RUS-HIG** Rear cab upper storage 245 litres - 440 mm high
 - TABLE** Folding and height adjustable table - on lower bunk
 - REF-ICPK** Fridge: engine tunnel mounted preparation kit
 - REFR-RUS** Fridge: 28 litre rear upper wall mounted with dividers
 - MICRO-PK** Preparation kit for microwave oven (wiring)
 - BOTH-D** One bottle holder under dashboard centre section
 - COFMA-PK** Coffee maker, preparation kit.
 - INLI-BAS** Interior white LED lights - basic
 - INLI-NL** Interior white and red night LED light with no dimmer
 - INLI-NLD** Interior white and red night LED light with dimmer
 - ARL-FLEX** Two flexible reading lamps (snake lamps)
 - RH-ECS** Glass roof & escape hatch - Electrically operated
 - RH-EE** Without roof hatch - Tinted glass emergency exit ONLY
 - RH-ETR** Glass roof & escape hatch - Electrically operated, tinted glass with rear opening
 - RH-MSR** Steel roof & escape hatch - Manually operated with rear opening
 - RH-MTR** Glass roof & escape hatch - Manually operated, tinted glass with rear opening
 - URH** Without roof hatch
 - SWIND-BS** Extra side window on both sides behind "B" pillar
 - SWIND-PS** Rear side window, passenger side
 - VANMIR** Vanity mirror in front shelf
 - AS-FUS** Extra shelf in front upper storage compartments
 - INFOT-PK** Preparation kit for the mounting of a flat screen TV in cab above the driver's door, includes bracket, electrical and speaker connections
- CAB EXTERIOR**
- PAICS-B** Basic cab paint - mirrors, sunvisor, instep and bumper supplied in natural finish - grey
 - PAICS-C** Complete cab - mirrors, insteps, sunvisor, and bumper finished in cab colour
 - GLAS-TIN** Tinted windows.
 - AWIND-RF** Rear window
 - DGLAS-L** Laminated door glass
 - LOCK-MAN** Manual door locking
 - LOCK-MRP** Manual door locking with internal remote control (from driver side) of passenger door
 - LOCK-REM** Central locking with remote control
 - BUMP-B2** Steel front bumper
 - GUARD-EH** Engine guard to protect sump and engine hoses
 - BUGNET** Insect screen in front of radiator
 - CTILT-P-E** Electrically operated hydraulic cab tilt
 - CTILT-P-M** Manually operated hydraulic cab tilt
 - FCABS-A** Front cab suspension - Air
 - FCABS-M** Front cab suspension - Mechanical spring
 - RCABS-A** Rear cab suspension - Air
 - RCABS-M** Rear cab suspension - Mechanical spring
 - MIRCOMF2** Electrically heated and operated FMX style main and wide-angle mirror on both sides, with manual passenger kerb mirror. To increase direct vision to the side the main mirrors have no cowlings
 - MIRCOMFM** Electrically heated and operated main with manual wide-angle mirror - both sides - and passenger kerb mirror
 - MIRSTD2** Electrically heated - FMX - main with wide angle mirror on both sides and kerb view mirror on passenger side, to increase direct vision to the side the main mirrors have no cowlings
 - MIRSTDFM** Electrically heated main mirror with wide angle mirror on both sides and kerb view mirror on passenger side
 - AMIR-F20** Auxiliary front view mirror with a 200mm radius
 - SUNV-H** External smoke grey sunvisor
 - AD-ROOF** Roof air deflector
 - AD-SIDEL** Side air deflector extension panels
 - AD-SIDES** Short cab side air deflector for rigid bodywork
 - HL-BASIC** Halogen H7 head lamps
 - HL-BHID** High intensity Bi-Xenon head lamps
 - HL-DBL** Bi-Xenon high intensity discharge and dynamic head lamps. Dipped beam follows the road, activated by a signal from the steering system.
 - HL-CLEAN** Head lamp cleaner - washer jets
 - HLP-ST** Headlamp protection
 - HL-ADJ** Headlight adjustment - Switch in cab
 - DRIVL2** Two spot lamps
 - UDRIVL** Without auxiliary driving lights
 - FOGL-WC** Front fog lights
 - CL-STAT** Static corner lights
 - ASL-RF2** Two Hella H11 70W spotlamps in sign box - only available with the basic headlight and no lower driving lights.
 - ASL-RFPK** Preparation kit for two spotlamps in sign box
 - BEACOA2F** Two front roof mounted amber beacon rotating warning lamps
 - BEACOA2R** Two rear roof mounted (on accessory bracket) amber beacon flashing warning LED lamps
 - BEACON-P** Roof beacon wire preparation
 - BEACONA4** Four roof mounted (2 front/2 rear) amber beacon rotating warning lamps
 - CABPT-R1** Single outlet for roof mounted accessories
 - CABPT-R2** Twin outlets for roof mounted accessories.
 - SPOTP-F** Spotlamp preparation in front, max 280W
 - SPOTP-R** Spotlamp preparation on roof, max 280W
 - SPOTP-RF** Spotlamp preparation on cab roof and in cab front, max 2x280W
 - ROS-IL2** Preparation kit for illuminated roof sign with switch loose in cab, fit after registration
 - CSGN-GTR** "Globetrotter" headboard logo
 - HORN-F1S** Single tone Jericho air horn chassis mounted
 - HORN-R2S** Two roof mounted air horns
 - ANT-CBR** Roof mounted antenna for CB radio, single aerial
 - ACCBP-AP** Front, middle & rear roof mounted accessory brackets
 - ACCBP-F** Front roof mounted accessory bracket
 - ACCBP-FM** Front & middle roof mounted accessory brackets
 - ACCBP-FR** Front & rear roof mounted accessory brackets
 - ACCBP-M** Middle roof mounted accessory bracket
 - ACCBP-R** Rear roof mounted accessory bracket
 - ACCBP-RM** Rear & middle roof mounted accessory brackets
 - REFS-CW** White cab conspicuity markings mounted on cab side
 - REFS-TW** White cab conspicuity markings by packed in cab
 - REFS-TY** Yellow cab conspicuity markings by packed in cab
- SUPERSTRUCTURE PREPARATIONS**
- BP-MI02**
 - BP-TI03**
 - SRWL-PK** Wiring preparation for side & rear work/reverse lamps on side of chassis and a three-position switch, maximum 280W
 - SWL-2FW** Two H3 70W white front chassis mounted (LH/RH side) working lamps and a 2-position switch (On/Off)
 - SWL-2RW** Two H3 70W white rear chassis mounted (LH/RH side) working lamps and a 2-position switch (On/Off)

Standard Equipment Optional Equipment

For more detailed information about cab and powertrain equipment, please refer to separate specification sheets.

For all possible options and combinations of options please consult your Volvo sales contact who can create a specification to match your requirements using the Volvo Sales Support system (VSS).

The factory reserves the right to modify design and change equipment without previous notification. The specification can vary from country to country.

MODEL RANGE

FM 11 6x4 Rigid - X-High Rear Air Suspension - N3G Straight front axle FM 64 R1CA

- **SWL-4W** 4 H3 70W white front (2) & rear (2) chassis mtd (LH/RH side) working lamps & 2-pos switch (On/Off)
- **SWL-PK** Wiring preparation for side work/reverse lamps on side of chassis and a three-position switch, maximum 280W
- **WLC-H2A** Two H3/70W working lamps with amber coloured lens high mounted back of cab
- **WLC-H2W** Two H3/70W white working lamps high mounted on the back of cab
- **WLC-PKCH** Preparation kit (cables and switch) for cab mounted chassis working lamp
- **WLC-PKH** Preparation kit, cables and switch for high mounted working lamps back of cab
- **WLC-PKL** Preparation kit, cables and switch for low mounted working lamps back of cab
- **WLC-PKLH** Preparation kit - cables and switch for low and high mounted working lamps back of cab.
- **ECBB-BAS** Body builder electrical centre without body builder module
- **ECBB-HIG** Body builder electrical centre with body builder module
- **BBCHAS1** One 7-pole connector for Body builder interface
- **BBCHAS3** Three 7-pole connectors for Body builder interface
- **BEPR-T2** Body builder electrical software preparation for tipper with remote control
- **EXSTER** External steering control, with VDS and bodybuilder module
- **TD-BAS** Trailer detection WITHOUT LED sensing
- **TD-LED** Trailer detection with LED sensing
- **FRFS-BS** Frame rail free space on both sides to give space for crane legs or other equipment.
- **FBA-BTF** Lower front body attachments for torsionally flexible - platform body
- **FBA-BTSF** Lower front body attachments for torsionally semi-flexible body - box or curtainsider
- **HBA-FSFB** Holes for body attachments - flexible/semi-flexible body
- **HBA-SB** Holes for body attachments - stiff body
- **RBA-T2** Lower rear body attachments for helper frame
- **CRANEPK1** Crane plates mounted to frame, for cranes up to 10 tonne metre capacity
- **CRANEPK2** Crane plates mounted to frame, for cranes up to 20 tonne metre capacity
- **CRANEPK4** Crane plates mounted to frame, for cranes up to 40 tonne metre capacity
- **AUXL-SPK** Electrical preparation kit - wiring and switch for snow plough lights
- **TAILPRE2** Tail lift preparation kit, wireless remote operation
- **TAILPREP** Taillift preparation kit - cab switch and warning in driver display
- **AESW2** Two Body builder bistable electrical switches (marked AUX1 / AUX2)
- **AESW2PK** 2 Body builder bistable el.switches (marked AUX1/AUX2) and prep. for 4 more switches
- **AUXSW-4** Wiring for 4 extra switches (from Body builder electrical centre to switch positions)

DELIVERY SERVICES

- **TGW-4GWL** GSM/GPRS/4G modem, LTE & WLAN for telematics gateway
- **FMS-PK** Fleet Management System gateway

VOLVO

Volvo Truck Corporation
volvotrucks.com