

MODEL RANGE

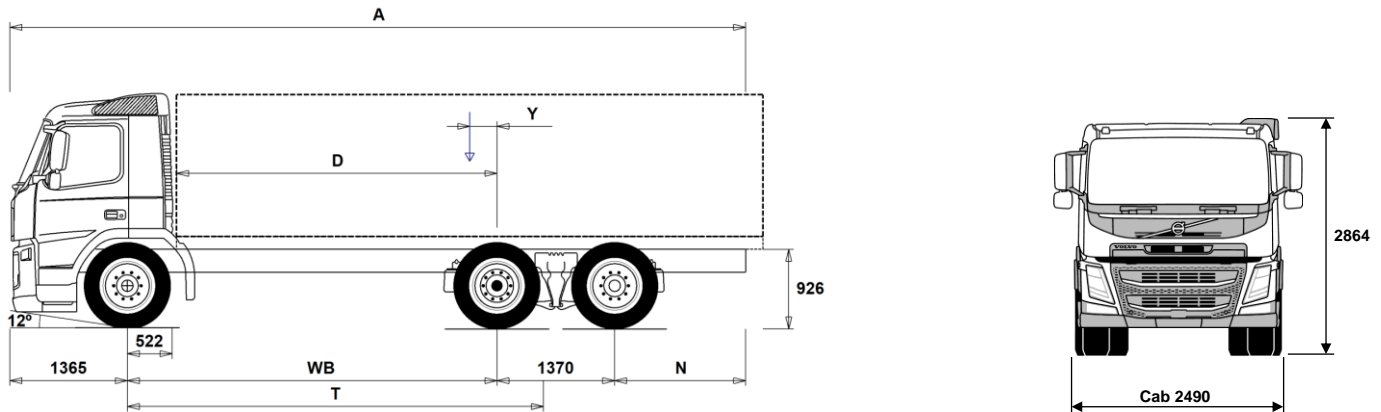

Volvo Trucks. Driving Progress

FM 13 6x2 Platform - Low Tag - Full Air Suspension FM 62 TR3LA



Chassis Dimensions [mm]

WB Wheelbase	3500	3700	3900	4300	4600	4800	4900	5200	5600	6000
A Overall Chassis Length	8160	8460	8760	9410	9860	10160	10310	10810	10960	10760
D Center of rear axle to front of body	2928	3128	3328	3728	4028	4228	4328	4628	5028	5428
N Rear Overhang (Min.)	1225	1225	1225	1225	1225	1225	1225	1225	1225	1225
N Rear Overhang (Max.)	1925	2025	2125	2375	2525	2625	2675	2875	2625	2025
T Theoretical Wheelbase	4041	4241	4441	4841	5141	5341	5441	5741	6141	6541
Y Center of Gravity for Payload (Min.)	88	117	146	203	244	273	288	332	379	421
Y Center of Gravity for Payload (Max.)	303	342	382	462	520	560	581	642	710	773

Chassis Weights [kg]

Front Axle	4125	4135	4145	4170	4195	4200	4205	4210	4260	4305
Rear Bogie	3075	3090	3100	3150	3180	3190	3200	3230	3210	3160
Kerb Weight	7200	7225	7245	7320	7375	7390	7405	7440	7470	7465
Payload (including body, driver, fuel, etc.)	18800	18775	18755	18680	18625	18610	18595	18560	18530	18535

Turning Diameter [mm]

Turning Circle Diameter Kerb to Kerb	14400	15000	15600	16800	17800	18400	18700	19600	20800	22000
Turning Circle Diameter Wall to Wall	15900	16500	17100	18300	19200	19800	20100	21100	22300	23500

Plated Weights [kg]

	Plated	Design
Gross Vehicle Weight	26000	27000
Gross Combination Weight	44000	44000
Front Axle	8000	8000
Rear Bogie	19000	19000

Important Notes

Chassis Dimensions

Cab Height: +416 mm for CAB-HSLP, -169 mm for CAB-LSLP, +554 mm for CAB-XHSL.

Front Axle to Back of Cab: +424 mm for CAB-HSLP and CAB-SLP and CAB-XHSL, +418 mm for CAB-LSLP.

D-measure includes a front clearance of 50 mm and for rigid trucks also a subframe of 100 mm.

Height can vary ± 20 mm for leaf and ± 10 mm for air suspension.

All dimensions are for unladen chassis and any tag axles down.

Rear overhang used for vehicle weight calculation is the maximum rear overhang (N Max.) for selected wheelbase.

Weight and dimensions are based upon the following tyres:

Front Axle Tyres:	315/70R22.5
Drive Axle Tyres:	315/70R22.5
Trailing/Pusher Axle Tyres:	315/70R22.5

Chassis weight includes oil, water, AdBlue, 0 litres fuel and without driver. Kerb weight can vary $\pm 3\%$.

Turning diameters are theoretically calculated. Tag axle used: TA-FIXED.

Legal weights can differ from country to country.

For more detailed weight information, including optional equipment weights, ask your Volvo sales contact to enter your specification into the Volvo Weight Information system (WIS).

Do NOT use this drawing for bodybuilding. Refer to Volvo Bodybuilder Instructions and chassis assembly drawing FM62TR3LA.

MODEL RANGE

FM 13 6x2 Platform - Low Tag - Full Air Suspension FM 62 TR3LA

TRUCK USE

- **RC-SMOOT** Operating class highway
- **GARB-PRE** Garbage preparation
- **SWAPBODY** Swap body vehicle preparation
- **UNIFORM** Basic platform vehicle

CORE COMPONENTS

- **CHH-LOW** Chassis height low - For a specific loading height always check the unique BEP chassis drawing
- **TA-HYSBS** Electro-hydraulic steered tag axle, with steering lock out at 38kph
8x2 models with rear steer will use the engine PTO to drive the steering pump, so will need an adapter.
- **TAG-FIXD** Tag axle - Fixed with twin tyres on tag axle
- **TAG-FIXS** Tag axle - Fixed with single tyres on tag axle
- **RADT-GR** Rear air suspension, 2 axles - 1 driven/1 tag
- **FM-DAY** Day cab - with steel safety cage design
Designed and built to Swedish impact and ECE R29 regulations
- **FM-HSLP** Globetrotter cab - with steel safety cage design
Designed and built to Swedish impact and ECE R29 regulations
- **FM-LSLP** Low sleeper cab - with steel safety cage design
Designed and built to Swedish impact and ECE R29 regulations
- **FM-SLP** Sleeper cab - with steel safety cage design
Designed and built to Swedish impact and ECE R29 regulations
- **FM-XHSL** Globetrotter LXL cab - with steel safety cage design
Designed and built to Swedish impact and ECE R29 regulations
- **EU6SCR** Emission level - Euro 6
- **D13 420S** D13K420 12.8 litre engine developing 420hp at 14-1800rpm.
Peak torque 2100Nm at 860 -1400rpm.
- **D13 460S** D13K460 12.8 litre engine developing 460hp at 14-1800rpm.
Peak torque 2300Nm at 900-1400rpm.
- **D13 500S** D13K500 12.8l engine developing 500hp at 14-1800rpm.
Peak torque 2500Nm at 1000-1400rpm.
- **D13K420** D13K420 - 420hp engine
- **D13K460** D13K460 - 460hp engine
- **D13K500** D13K500 - 500hp engine
- **EBR-EPG** Exhaust brake controlled by steering column switch
- **EBR-EPGC** Exhaust pressure governor for I shift gearbox
- **EBR-VEB+** Volvo engine brake + and exhaust pressure governor, enhanced performance from additional exhaust rocker control. Retardation 375kW
- **AT2412F** AT2412F 12-speed "I-shift" automated mechanical gearbox suitable for gross train weights up to 44tonne only refer to sales engineering when used in conjunction with a PTO
- **AT2612F** AT2612F 12-speed "I-shift" automated mechanical gearbox suitable for gross train weights up to 60tonne only refer to sales engineering when used in conjunction with a PTO
- **ATO2612F** ATO2612F 12-speed "I-shift" overdrive automated mechanical gearbox suitable for gross train weights up to 60tonne refer to sales engineering when used in conjunction with a PTO
- **PT2606** Powertronic automatic 6-speed gearbox, max. engine torque 2600 Nm, max. permitted GCW 130000 kg
- **SPO2812** SPO2812 - 12 speed I-shift Dual Clutch automated mechanical gearbox GCW 60tonne
- **RSH1370F** RSH1370F hub reduction rear axle with differential lock - design GCW 70 tonne
- **RSS1344E** RSS1344E single reduction rear axle with differential lock - design GCW 44tonne
- **RSS1352A** RSS1352A single reduction 13 tonne rear axle with differential lock - design GCW 52 tonne

■ Standard Equipment

□ Optional Equipment

For more detailed information about cab and powertrain equipment, please refer to separate specification sheets.

For all possible options and combinations of options please consult your Volvo sales contact who can create a specification to match your requirements using the Volvo Sales Support system (VSS).

The factory reserves the right to modify design and change equipment without previous notification. The specification can vary from country to country.

- **RSS1356** RSS1356 single reduction rear axle with differential lock - design GCW 56 tonne
- **RSS1370A** RSS1370A single reduction 13 tonne rear axle with differential lock - design GCW 70 tonne
- **RSS1370B** RSS1370B single reduction 13 tonne rear axle with differential lock - design GCW 70 tonne

PACKAGES

- **LHFP-VE** Long Haul Fuel Economy driving package
- **LHFP-VE+** Long Haul Fuel Economy plus driving package
- **DRIVEFM** Cab Package: Drive
- **DRIVEFM+** Cab Package: Drive +
- **BEDFM** One bed resting package
- **AUDHIG** High Power Audio system: RDS radio with CD player - also playing MP3/WMA files from CD -, with integrated bluetooth phone and USB/Line inputs. FM/AM antenna, speakers in dashboard, doors, and sleeping compartment. AM/FM Bluetooth radio without CD player.
- **MEDIA** USB and Aux line inputs. Speakers in dashboard, doors, and sleeping compartment. 7" touch screen with personal apps. AM/FM Bluetooth radio without CD player. USB and Aux line inputs. Speakers in dashboard, doors, and sleeping compartment. 7" touch screen with personal and professional apps. Dynafleet vehicle on-board data display with office internet support.
- **MEDIADF** AM/FM Bluetooth radio without CD player. USB and Aux line inputs. Speakers in dashboard, doors, and sleeping compartment. 7" touch screen with personal and professional apps. Dynafleet vehicle on-board data display with office internet support.
- **MEDIANAV** AM/FM Bluetooth radio without CD player. USB and Aux line inputs. Speakers in dashboard, doors, and sleeping compartment. 7" touch screen with personal and professional apps. Truck based satellite navigation (live updates not included) AM/FM Bluetooth radio without CD player. USB and Aux line inputs. Speakers in dashboard, doors, and sleeping compartment. 7" touch screen with personal and professional apps. Truck based satellite navigation (live updates not included) Dynafleet vehicle on-board data display with office internet support.
- **MEDIANDF** AM/FM Bluetooth radio without CD player. USB and Aux line inputs. Speakers in dashboard, doors, and sleeping compartment. 7" touch screen with personal and professional apps. Truck based satellite navigation (live updates not included) Dynafleet vehicle on-board data display with office internet support.
- **VISI15** Visibility Package
- **VISI15+** Visibility Plus Package
- **ASAF15** Active Safety Package

CHASSIS

- **FST-AIR** Front suspension type - air
- **FSL5-HI** Front suspension levelling - high stroke for demount operations - check with bodybuilder
- **FAL7.1** Front axle design capacity 7.1 tonnes
- **FAL7.5** Front axle design capacity 7.5 tonnes
- **FAL8.0** Front axle design capacity 8.0 tonnes - Ensure that you have checked the tyre load index
- **FSTAB2** Front anti-roll bar medium stiffness
- **FSTAB3** Front stiff anti-roll bar
- **RSL5-BAS** Rear air suspension basic levelling stroke
- **RSL5-HI** Rear air suspension high levelling stroke
- **RAL19** Rear bogie design capacity 19 tonnes
- **RSTAB2** Rear anti roll bar medium stiffness
- **RSTAB3** Rear stiff anti-roll bar
- **RALIM10** Rear axle load limiter, 10 tonnes
- **RALIM105** Rear axle load limiter, 10.5 tonnes
- **RALIM115** Rear axle load limiter, 11.5 tonnes
- **RALIM95** Rear axle load limiter, 9.5 tonnes
- **ASF-DL1** Air suspension with 1 driving level
- **ASF-DL3** Air suspension with 3 driving levels
- **ACTST-TO** Volvo Dynamic Steering (VDS) with with extra electronic pump and torque overlay
- **ASFE-BAS** Active steering feature - Basic - Volvo Dynamic Steering only

MODEL RANGE

FM 13 6x2 Platform - Low Tag - Full Air Suspension FM 62 TR3LA

- | | |
|---|--|
| <ul style="list-style-type: none"> <input type="checkbox"/> ASFE-PS Active steering feature - Volvo Dynamic Steering with personal settings <input checked="" type="checkbox"/> PSS-SING Single power steering system <input checked="" type="checkbox"/> PSP-FIX Power steering pump with fixed displacement <input type="checkbox"/> PSP-VAR Power steering pump with variable displacement <input checked="" type="checkbox"/> EBS-MED EBS medium package including "hill" hold function <input checked="" type="checkbox"/> FRAME266 Frame rail section external height 266 mm <input type="checkbox"/> FIL-EEEB Inner liner from end of engine to end of bogie <input type="checkbox"/> FIL-EEEF Inner liner from end of engine to end of frame <input type="checkbox"/> FIL-FBEB Inner liner over rear bogie <input type="checkbox"/> FIL-FBEF Inner liner from front of bogie to end of frame <input type="checkbox"/> FIL-TXEB Inner liner from gearbox member to end of bogie <input type="checkbox"/> FIL-TXEF Inner liner from gearbox member to end of frame <input checked="" type="checkbox"/> BBOX-L Battery box located on left hand side <input type="checkbox"/> BATS-D Dual energy battery system - 2 living batteries and 2 starter batteries. <input checked="" type="checkbox"/> BATS-S Single energy battery system (2 batteries) <input type="checkbox"/> 2BAT210B 2 x 210 Ah capacity Gel batteries <input checked="" type="checkbox"/> 2BATT170 2 x 170 Ah capacity batteries <input type="checkbox"/> 2BATT225 2 x 225 Ah capacity batteries <input checked="" type="checkbox"/> BATTAMP Battery voltage and ampere gauge <input type="checkbox"/> BATTIND Battery charge indication <input type="checkbox"/> ADR2 ADR package for transportation of dangerous goods on road (Note does NOT include safe loading pass package if required this is quoted separately) <input type="checkbox"/> MSWI-A Main switch - ADR switch circuit shut down <input checked="" type="checkbox"/> MSWI-C Main switch - Chassis mounted toggle switch by battery box <input type="checkbox"/> MSWI-R Main switch - Key fob operated remote controlled <input checked="" type="checkbox"/> R315A56 Right aluminium 560 mm D-shaped fuel tank, 315 litres volume
Min volume 255l
Max volume 885l <input checked="" type="checkbox"/> UL-FUEL Without left fuel tank
Min volume 160l
Max volume 540l <input type="checkbox"/> ADTP-L AdBlue tank on left hand side <input checked="" type="checkbox"/> ADTP-R AdBlue tank on right hand side <input checked="" type="checkbox"/> ADB048 AdBlue tank usable volume 48 litres <input type="checkbox"/> ADB068 AdBlue tank usable volume 68 litres <input type="checkbox"/> ADB100 AdBlue tank usable volume 100 litres <input type="checkbox"/> ADTC-BF AdBlue tank cover with satin alloy look decorative cover <input checked="" type="checkbox"/> FCAP-L Locking fuel filler cap <input checked="" type="checkbox"/> FUFF-AS Fuel filling anti-spillage device <input type="checkbox"/> FUFF-ATS Fuel filling anti-theft and anti-spillage devices <input type="checkbox"/> ESH-LEFT Horizontal silencer, left exhaust outlet <input checked="" type="checkbox"/> ESH-REAR Horizontal silencer, rear exhaust outlet <input type="checkbox"/> ESH-VERT Horizontal silencer, vertical exhaust outlet <input type="checkbox"/> EXST-SSP Stainless steel exhaust stack - NOT polished <input type="checkbox"/> EXST-ST Steel exhaust stack <input type="checkbox"/> HS-NAR Narrow heat shield <input type="checkbox"/> WHC-FIX2 Two fixed wheel chocks <input type="checkbox"/> WHC-FOL2 Two foldable wheel chocks <input type="checkbox"/> WHCP-F Wheel chock(s) stored in the front part of the vehicle <input type="checkbox"/> WHCP-M Wheel chock(s) stored in the middle part of the vehicle <input type="checkbox"/> WHCP-R Wheel chock(s) stored in the rear part of the vehicle <input type="checkbox"/> WHCP-T Transport mounted wheel chock(s) stored in cab outer luggage locker <input type="checkbox"/> TB-L80 Toolbox 800 mm, left side <input type="checkbox"/> TB-R80 Toolbox 800 mm, right side <input type="checkbox"/> CHAIN-S Snow chains | <ul style="list-style-type: none"> <input type="checkbox"/> HOOK-SC Snow chain hooks <input checked="" type="checkbox"/> TOWF-NO1 One front towing device <input type="checkbox"/> TOWF-NO2 Two front towing devices <input type="checkbox"/> TOWMBRH Towing member, high mounted in centre of frame, D = 190 <input type="checkbox"/> TOWMBRL1 Towing member, low mounted under the frame <input type="checkbox"/> TOWMBRL2 Towing member, low and forward mounted under the frame <input type="checkbox"/> TOWMBRL3 Towing member, low and far forward mounted under the frame <input type="checkbox"/> TOWMBRM Towing member, medium mounted in line with frame lower flange <input type="checkbox"/> RFEC-L Rear frame end, lower flange cut for centre axle drawbar. <input checked="" type="checkbox"/> RFEC-S Rear frame end, straight cut for regular platform applications <input type="checkbox"/> RFEC-U Rear frame end, upper cut for tipper applications. <input type="checkbox"/> C-RI4040 Towing coupling, Ringfeder 4040 G-150 <input type="checkbox"/> C-RI5055 Towing coupling, Ringfeder 5055 G-150 <input type="checkbox"/> C-RO400G Towing coupling, Rockinger 400 G-150 for 40mm eyes <input type="checkbox"/> C-RO50 Rockinger RO 50 50mm for centre axle trailer <input type="checkbox"/> TOWR-ONE Towing hitch attached to rear crossmember <input checked="" type="checkbox"/> TREL-PK Trailer electrical preparation kit - chassis/cab wiring <input type="checkbox"/> TREL14 Single 14 pole electrical trailer connector <input type="checkbox"/> TREL15 Single 15 pole electrical trailer connector - ADR certified <input type="checkbox"/> TREL7 7 pole - 24N trailer electrical suzie <input type="checkbox"/> TREL7-7 24N and 24S trailer electrical suzies <input type="checkbox"/> TBC-DUO Duomatic type air line connectors <input type="checkbox"/> TBC-EC Palm coupling type air line connectors <input type="checkbox"/> TRBR-HCF Full pressure hand controlled trailer brake <input type="checkbox"/> TRBR-STA Stationary trailer brake control <input type="checkbox"/> TRB-STRE Stretch Brake - Automatic low speed trailer brake activation to avoid jack-knifing and improve steerability <input type="checkbox"/> RUP-FOLD Folding EC approved aluminium rear underrun <input type="checkbox"/> RFEND-B Three piece EC approved rear mud wings and spray flaps <input type="checkbox"/> RFEND-T Rear mud wings, transport mounted <input type="checkbox"/> RFH-BAS Basic rear wing height <input type="checkbox"/> RFH-HIG High rear wing height - higher wing tops <input type="checkbox"/> RFH-LOW Lower rear wing height - shallower wing tops <input type="checkbox"/> AUXATNK Auxiliary airtank <input type="checkbox"/> ATANK-AL Aluminium air tanks <input checked="" type="checkbox"/> ATANK-ST Steel air tanks <input type="checkbox"/> RESTS-W White conspicuity markings on chassis - sideguards, toolbox and rear overhang <input type="checkbox"/> REST-RUP <input checked="" type="checkbox"/> TL-LED Rear lights LED <input type="checkbox"/> BLIGHT-E Emergency brake light |
|---|--|
- WHEELS & TYRES**
- | |
|--|
| <ul style="list-style-type: none"> <input type="checkbox"/> RT-AL Alcoa brushed aluminium rims with standard holes for long stud fixing on all axles <input type="checkbox"/> RT-ALDP Alcoa Dura-Bright EVO aluminium rims with standard holes long stud fixing on all axles, requires cleaning with a ph neutral solution - washing up liquid. <input type="checkbox"/> RT-ALDPD Alcoa Dura-Bright EVO aluminium rims with countersunk holes for short stud fixing on all axles, requires cleaning with a ph neutral solution - washing up liquid. <input type="checkbox"/> RT-ALDU Alcoa brushed aluminium rims with countersunk holes for short stud fixing on all axles <input checked="" type="checkbox"/> RT-STEEL Steel rims on all axles <input type="checkbox"/> WCAP Aerodynamic hub caps <input type="checkbox"/> BRREC001 Bridgestone ECOPIA H - Energy rating C <input type="checkbox"/> COREC001 Continental ECOPLUS HS3 XL/HD3 - Energy rating B or C depending on size <input type="checkbox"/> COREC002 Continental ECOPLUS HS3/HD3 - Energy rating B or C depending on size <input type="checkbox"/> COREC003 Continental Efficient Pro S/D - Fuel Tyre Recommendation 3 Reduced mileage compared to Conti EcoPlus long haul pattern please consider when selecting these tyres. |
|--|
- Standard Equipment □ Optional Equipment

For more detailed information about cab and powertrain equipment, please refer to separate specification sheets.

For all possible options and combinations of options please consult your Volvo sales contact who can create a specification to match your requirements using the Volvo Sales Support system (VSS).

The factory reserves the right to modify design and change equipment without previous notification. The specification can vary from country to country.

MODEL RANGE

FM 13 6x2 Platform - Low Tag - Full Air Suspension FM 62 TR3LA

- GYREC001** Goodyear FUELMAX S/HL/D - Energy rating B or C depending on size
 - GYREC002** Goodyear FUELMAX S/D - Energy rating B or C depending on size
 - GYREC004** Goodyear FUELMAX S - Energy rating B depending on size
 - HAREC001** Hankook AL10+ E-Cube Max Long Haul Tyre - Energy rating B
 - HAREC002** Hankook AL10+ E-Cube Long Haul Tyre - Energy rating B with wide single
 - MIREC001** Michelin XFA2/X-LINE Energy - Fuel tyre Recommendation 1
 - MIREC003** Michelin X-LINE Energy - Fuel tyre Recommendation 3
 - MIREC004** Michelin X Line Energy F/D2 - Energy rating A
 - PIREC001** Pirelli FH:01 Proway - Long Haul Tyre - Energy rating B
 - PIREC002** Pirelli FH:01 II Long Haul Tyre - Energy rating B with wide single

 - SPWT-D** Spare wheel & tyre with rear tyre pattern
 - SPWT-F** Spare wheel & tyre with front tyre pattern

 - SWCP-LF** Spare wheel carrier on left side of chassis ahead of rear axle
 - SWCP-R** Rear mounted spare wheel carrier
 - SWCP-T** Spare wheel supplied temporarily strapped to chassis
 - SWCP-TP** Temporary spare wheel carrier on top of chassis frame

 - JACK-12T** 12 tonne bottle jack
 - TOOL-BAS** Basic Toolkit
 - TOOLKIT** Complete tool kit
 - INFLAHOS** Tyre inflation hose
 - GAUGE-TP** Tyre pressure gauge
- ### DRIVELINE EQUIPMENT
- ASO-C** Crawler gear -
Ratio direct top gearbox 19:1
Ratio Overdrive gearbox 17:1
 - ASO-ULC** Ultra low crawler and crawler gear -
Ratios direct top gearbox 32:1 and 19:1
Ratios Overdrive box 32:1 and 17:1
 - TRAP-HD** Reinforced gearbox application
 - TP-CON** Construction Package
 - TP-DIST** Distribution Package
 - TP-LONG** Long Haul Package
 - AMSO-AUT** Enhanced I-shift software with manual shift available in auto mode and kickdown facility on accelerator pedal
 - AVO-ENH** Enhanced software for off road driveability and starting
 - APF-ENH** I-shift enhanced PTO functions
 - RET-TH** Gearbox mounted retarder
 - RET-TPT** Hydraulic Retarder for Powertronic gearbox
 - TC-HWO** Automatic gearbox oil cooler - water to oil
 - TC-MAOH2** Extra high performance transmission oil cooler - air to oil with front mounted radiator
 - TC-MWO** Basic transmission oil cooler - water to oil
 - 2COM1100** Two cylinder, air compressor, 1100 litres per minute
 - 2COMP900** Two cylinder, air compressor, 900 litres per minute
 - CLU-AIRC** Clutchable air compressor
 - AIRIN-HI** Roof mounted air intake behind cab on left hand side
 - AIRIN-LO** Low level air intake behind cab on left hand side
 - ACL1ST-S** Two stage air filter
 - 24AL110B** 110 amp alternator
 - 24AL120B** 120 amp alternator
 - 24AL150B** 150 amp alternator
 - CCV-C** Closed crankcase engine ventilation
 - CCV-O** Open crankcase engine breather
 - CCV-OX** Closed crankcase ventilation for cold markets
 - PRIM-EL** Electrical priming pump
 - PRIM-MAN** Manual priming pump
 - FUEQ-EH** Fuel line electric heater

 - AF-R** Hot fuel recirculation heated fuel filter
 - FUEFE2LW** Large engine mounted dual fuel filter with water separator
 - FUEFE2SW** Small engine mounted dual fuel filter with water separator
 - EST-AID** Air inlet manifold starting heater element
 - 220EBH15** 220V/1.5Kw electric engine block heater
 - PTER-100** Rear engine mounted power-take-off with DIN 100 / ISO 7646 flange
 - PTER-DIN** Rear engine mounted PTO with DIN5462 (female) splined shaft for a close coupled pump.
Models with 3 steering axles will use this to drive the steering pump (AUXPSP)
 - PTER1400** Rear engine mounted power-take-off with SAE 1410 flange
 - HPE-F101** Parker F1-101, engine mounted, fixed displacement, single flow, engine mounted hydraulic pump
 - HPE-F41** Parker F1-41, engine mounted, fixed displacement, single flow, engine mounted hydraulic pump
 - HPE-F51** Parker F1-51, engine mounted, fixed displacement, single flow, engine mounted hydraulic pump
 - HPE-F61** Parker F1-61, engine mounted, fixed displacement, single flow, engine mounted hydraulic pump
 - HPE-F81** Parker F1-81, engine mounted, fixed displacement, single flow, engine mounted hydraulic pump
 - HPE-T53** Parker F2-53/53, engine mounted, Fixed displacement, Twin flow engine mounted hydraulic pump
 - HPE-T70** Parker F2-70/35, engine mounted, Fixed displacement, Twin flow engine mounted hydraulic pump
 - HPE-V45** Parker VP1-45, variable displacement, single flow, engine mounted hydraulic pump
 - HPE-V75** Parker VP1-75, variable displacement, single flow, engine mounted hydraulic pump
 - PTPT-D** Powertronic PTO, 1 front/upper DIN connection for plug-in pump (max. 850 Nm)
 - PTPT-F** Powertronic PTO, 1 front/upper rear facing SAE flange conn. for prop shaft (max.850 Nm)
 - PTR-D** Gearbox PTO for plug-in pump, 0.71xeng speed
 - PTR-DH** Gearbox driven high speed PTO for one plug-in hydraulic pump
 - PTR-DM** Gearbox driven medium speed PTO for one plug-in hydraulic pump
 - PTR-F** Gearbox driven PTO with rear flange connection
 - PTR-FH** Gearbox driven high speed PTO with SAE drive flange
 - PTR-FL** Gearbox driven low speed PTO with SAE drive flange
 - PTRD-D** Gearbox driven HIGH SPEED PTO for two plug-in hydraulic pumps
 - PTRD-D1** PTRD-D1 Gearbox driven HIGH SPEED PTO (1 SAE flange & 1 plug-in hydraulic pump)
 - PTRD-D2** Gearbox driven HIGH SPEED PTO (2 SAE flanges & 1 plug-in hyd pump)
 - PTRD-F** PTO with 1 DIN + 1 flange connection rear, manual gearbox
 - HPG-F101** Parker F1-101 gearbox mounted, fixed displacement, single flow, hydraulic pump
 - HPG-F41** Parker F1-41 gearbox mounted, fixed displacement, single flow, hydraulic pump
 - HPG-F51** Parker F1-51 gearbox mounted, fixed displacement, single flow, hydraulic pump
 - HPG-F61** Parker F1-61 gearbox mounted, fixed displacement, single flow, hydraulic pump
 - HPG-F81** Parker F1-81 gearbox mounted, fixed displacement, single flow, hydraulic pump
 - EIDLESD** Engine idle shut down
 - DTRI-PER** Dashboard in darker peregrine greyish brown. Steering wheel grey and door panels in light beige for FH and black for FH16.
 - STWPOS-R** RIGHT HAND DRIVE
 - STWM-LE** Leather steering wheel
 - STGW-AD2** Adjustable steering wheel with neck tilt
 - STGW-ADJ** Adjustable steering wheel
 - AIRBAG** SRS Driver's air bag
 - DRC-AMII** DPF Regeneration control switch - for manual and switching off

Standard Equipment Optional Equipment

For more detailed information about cab and powertrain equipment, please refer to separate specification sheets.

For all possible options and combinations of options please consult your Volvo sales contact who can create a specification to match your requirements using the Volvo Sales Support system (VSS).

The factory reserves the right to modify design and change equipment without previous notification. The specification can vary from country to country.

MODEL RANGE

FM 13 6x2 Platform - Low Tag - Full Air Suspension FM 62 TR3LA

- | | |
|---|--|
| <ul style="list-style-type: none"> regeneration ■ 1DAYDIG2 Continental VDO DTCO 4.0 smart tachograph
This tachograph can ONLY offer remote download if the option of Dynafleet or an FMS gateway has been specified with this order. □ 1DAYDIGP Continental VDO DTCO 3.0 digital tachograph
For vehicles with long lead time - this includes prep kit for the retrofit of DTCO 4.0 tachograph.
For updating to new legal demand for truck registration from 15th June 2019.
This tachograph can ONLY offer remote download if the option of Dynafleet or an FMS gateway has been specified with this order. □ ARSL Additional road speed limit - switch in dashboard □ SPEED-DU Dual speed limiter □ CRUIS-E Eco cruise control (with eco-roll and I-cruise, controls in steering wheel) ■ CRUISEC Cruise control, standard ■ ESP-BAS1 Electronic Stability Control □ ESPC-RO ESP (Electronic Stability Program) functionality control - Reduced / Off □ HWSS-ACB Adaptive cruise control ACC with forward collision warning and AEBs advanced emergency brake system ■ HWSS-FCB Forward collision warning with AEBs advanced emergency brake system ■ LSS-DW Lane departure-warning system □ LCS Lane change support □ DAS-W Driver Alert Support system □ RSENS-W Rain sensing windscreen wipers □ CU-ECC Electrically controlled air conditioning with sun sensor □ CU-ECC2 Electrically controlled air conditioning with sun sensor, mist sensor, air quality sensor and carbon filter ■ CU-MCC Climate unit with manual controlled air conditioning ■ IMMOBIL Thatcham H2 approved immobiliser □ ALARM-B Thatcham H1 approved vehicle alarm - Cab only □ ALARM-E Enhanced vehicle alarm - Thatcham H1 approved - Cab plus external sensor for body/trailer □ ALCOLOCK Alcolock □ BUPMON Back up monitor with built in 7" screen on dash and one colour camera supplied loose for fitment by bodybuilder.
Can accommodate up to 4 cameras for TfL Safe Scheme, CLOCS and FORS. □ PHONE-PK Telephone preparation kit (antenna, antenna attachm. cable incl.) □ WLIFT-AD Electrical window lift, automatic up/down driver side ■ WLIFT-EB Electrical window lift □ WLIFT-ME Mechanical window lift □ ISUNS-BS Side interior sun visor on both sides ■ ISUNS-DS Driver's side interior sun visor ■ ISUNF-B Interior front sun visor without mirror □ ISUNF-MD Interior front sun visor with mirror on driver side □ ISUNF-RE Electrically operated textile interior sun blind □ ISUNF-RM Manually operated textile interior sun blind □ ADFS Two extra DIN slots in front shelf - can be fitted with card or drawer available as an accessory ■ BUPALARM Reverse alarm □ RTOLL-PK Road toll PREPARATION kit for trucks operating with "Toll Collect" in Germany □ LOADIND Load indicator with central dashboard display | <ul style="list-style-type: none"> □ REMC-MF Multi-function wireless remote control □ FIREXT3S 3kg fire extinguisher mounted on seat base □ WARNVEST High visibility warning vest - no sleeves □ AIDKIT First aid kit □ AIDKIT1B First aid kit □ WARNLAMP Portable warning lamp □ LAMP-IN Inspection lamp □ BULBKIT Bulb and fuse kit □ WRITEPAD Writing pad □ UPHTRI10 Seats: Black embossed textile insert with light grey sides, black vinyl side bolster with blue vinyl side insert.
Interior trim: Raven black bunk and curtains & blue textile side walls □ UPHTRI11 Seats: Light grey embossed textile insert, black raven metallic vinyl bolster with red vinyl side insert.
Interior trim: Raven black bunk and curtains & grey vinyl side walls □ UPHTRI12 Seats: Blue soft textile insert, black vinyl bolster.
Interior trim: Raven black bunk and curtains & blue textile side walls □ UPHTRI13 Seats: Dark grey leather insert and black leather bolster.
Interior trim: Raven black bunk and curtains & grey vinyl side walls □ UPHTRI14 Seat: Dark grey leather insert and black leather bolster.
Interior trim: Raven black bunk and curtains & blue textile side walls ■ DST-CF4 Driver seat, comfort, suspended, belt in seat □ DST-CF5 Driver seat, comfort, suspended, belt in seat, electrically heated □ DST-CF6 Driver seat, comfort, suspended, belt in seat, electrically heated, ventilated □ SBD-RED Red seat belts □ SBPRE-DS Driver seat belt pretensioner ■ PST-BAS1 Passenger seat - Fixed non suspended fold up with seatbelt mounted in cab □ PST-BENC Bench passenger seat □ PST-CF4 Passenger seat - Comfort suspended with seatbelt mounted in seat □ PST-CF5 Passenger seat - Comfort suspended & heated with seatbelt mounted in seat □ PST-STD2 Passenger seat - Fixed non suspended with seatbelt mounted in cab □ PST-STD4 Passenger seat - Standard suspended with seatbelt mounted in cab □ SBPRE-PS Passenger seat belt pretensioner □ ARM-DBPS Two armrests on driver seat and one (outer) on passenger seat □ ARMRE-BB Two armrests on both driver and passenger seat. □ ARMRE-DB Two armrests, on driver seat only □ ARMRE-PB Two armrests, on passenger seat only □ ARMRE-PS Single armrest (next to driver) on passenger seat □ ARU-BAS Vinyl upholstered armrest □ ARU-LEA Leather upholstered armrest ■ FMAT-RUB Rubber floor mats □ FMAT-TX2 Textile and rubber floor mats □ LBK-RES Foldable rest bunk □ LBK70 Lower bunk 700 x2000 mm, fixed ■ ULBK Without lower bunk □ MATL-FI Firm lower bunk pocket sprung mattress □ MATL-SF Lower flexizone mattress - semi-firm, pocket springs up to 100kg - 16 stone □ MATL-SO Lower flexizone mattress - soft, pocket springs up to 85kg - 13.5 stone □ OLMAT-BA 35mm mattress overlay protector |
|---|--|

■ Standard Equipment

□ Optional Equipment

For more detailed information about cab and powertrain equipment, please refer to separate specification sheets.

For all possible options and combinations of options please consult your Volvo sales contact who can create a specification to match your requirements using the Volvo Sales Support system (VSS).

The factory reserves the right to modify design and change equipment without previous notification. The specification can vary from country to country.

MODEL RANGE

FM 13 6x2 Platform - Low Tag - Full Air Suspension FM 62 TR3LA

- OLMAT-PR** 50mm premium mattress overlay protector
 - TBK60F** Fixed foldable top bunk 600 x 1900mm
 - TBK70F** Fixed foldable top bunk 700 x 1900mm
 - PH-CAB2** 1.8kW Air to air night heater
 - PH-ENGCA** Engine and cab night heater
 - PH-SS** Short stop heater
 - SLCP-BAS** Basic sleeper control panel - includes interior light, parking heater, roof hatch and door lock
 - SAFE** Safe box for driver's personal items
 - ETSB-F** Storage on engine tunnel - on front top
 - ETSB-FR** Storage on engine tunnel - on front top and at rear cab wall
 - ETSB-FRS** Storage on engine tunnel - on front top & at rear cab wall & storage recessed into tunnel on right hand side
 - ETSB-FS** Storage on engine tunnel - on front top and storage recessed into tunnel on right hand side
 - ETSB-R** Storage on engine tunnel - box at rear cab wall
 - ETSB-RS** Storage on engine tunnel - at rear cab wall and storage recessed into tunnel on right hand side
 - ETSB-S** Storage on engine tunnel - recessed into tunnel on right hand side
 - RUS-BAS** Rear cab upper storage 154 litres - 300 mm high
 - RUS-HIG** Rear cab upper storage 245 litres - 440 mm high
 - TABLE** Folding and height adjustable table - on lower bunk
 - REF-ICPK** Fridge: engine tunnel mounted preparation kit
 - REFR-RUS** Fridge: 28 litre rear upper wall mounted with dividers
 - MICRO-PK** Preparation kit for microwave oven (wiring)
 - BOTH-D** One bottle holder under dashboard centre section
 - COFMA-PK** Coffee maker, preparation kit.
 - INLI-BAS** Interior white LED lights - basic
 - INLI-NL** Interior white and red night LED light with no dimmer
 - INLI-NLD** Interior white and red night LED light with dimmer
 - ARL-FLEX** Two flexible reading lamps (snake lamps)
 - RH-ECS** Glass roof & escape hatch - Electrically operated
 - RH-EE** Without roof hatch -Tinted glass emergency exit ONLY
 - RH-ETR** Glass roof & escape hatch - Electrically operated, tinted glass with rear opening
 - RH-MSR** Steel roof & escape hatch - Manually operated with rear opening
 - RH-MTR** Glass roof & escape hatch - Manually operated, tinted glass with rear opening
 - URH** Without roof hatch
 - SWIND-BS** Extra side window on both sides behind "B" pillar
 - SWIND-PS** Rear side window, passenger side
 - VANMIR** Vanity mirror in front shelf
 - AS-FUS** Extra shelf in front upper storage compartments
 - INFOT-PK** Preparation kit for the mounting of a flat screen TV in cab above the driver's door, includes bracket, electrical and speaker connections
- ### CAB EXTERIOR
- PAICS-B** Basic cab paint - mirrors, sunvisor, instep and bumper supplied in natural finish - grey
 - PAICS-C** Complete cab - mirrors, insteps, sunvisor, and bumper finished in cab colour
 - GLAS-TIN** Tinted windows.
 - AWIND-RF** Rear window
 - DGLAS-L** Laminated door glass
 - LOCK-MAN** Manual door locking
 - LOCK-MRP** Manual door locking with internal remote control (from driver side) of passenger door
 - LOCK-REM** Central locking with remote control
 - BUMP-B** Plastic front bumper
 - BUMP-B2** Steel front bumper
 - BUGNET** Insect screen in front of radiator
 - CTILT-P-E** Electrically operated hydraulic cab tilt
 - CTILT-P-M** Manually operated hydraulic cab tilt
 - FCABS-A** Front cab suspension - Air
 - FCABS-M** Front cab suspension - Mechanical spring
 - RCABS-A** Rear cab suspension - Air
 - RCABS-M** Rear cab suspension - Mechanical spring
 - MIRCOMF2** Electrically heated and operated FMX style main and wide-angle mirror on both sides, with manual passenger kerb mirror. To increase direct vision to the side the main mirrors have no cowlings
 - MIRCOMFM** Electrically heated and operated main with manual wide-angle mirror - both sides - and passenger kerb mirror
 - MIRSTD2** Electrically heated - FMX - main with wide angle mirror on both sides and kerb view mirror on passenger side, to increase direct vision to the side the main mirrors have no cowlings
 - MIRSTDFM** Electrically heated main mirror with wide angle mirror on both sides and kerb view mirror on passenger side
 - AMIR-F20** Auxiliary front view mirror with a 200mm radius
 - SUNV-H** External smoke grey sunvisor
 - AD-ROOF** Roof air deflector
 - AD-SIDEL** Side air deflector extension panels
 - AD-SIDES** Short cab side air deflector for rigid bodywork
 - HL-BASIC** Halogen H7 head lamps
 - HL-BHID** High intensity Bi-Xenon head lamps
 - HL-DBL** Bi-Xenon high intensity discharge and dynamic head lamps. Dipped beam follows the road, activated by a signal from the steering system.
 - HL-CLEAN** Head lamp cleaner - washer jets
 - HLP-ST** Headlamp protection
 - HL-ADJ** Headlight adjustment - Switch in cab
 - DRIVL2** Two spot lamps
 - UDRIVL** Without auxiliary driving lights
 - FOGL-WC** Front fog lights
 - CL-STAT** Static corner lights
 - ASL-RF2** Two Hella H11 70W spotlamps in sign box - only available with the basic headlight and no lower driving lights.
 - ASL-RFPK** Preparation kit for two spotlamps in sign box
 - BEACOA2F** Two front roof mounted amber beacon rotating warning lamps
 - BEACOA2R** Two rear roof mounted (on accessory bracket) amber beacon flashing warning LED lamps
 - BEACON-P** Roof beacon wire preparation
 - BEACONA4** Four roof mounted (2 front/2 rear) amber beacon rotating warning lamps
 - CABPT-R1** Single outlet for roof mounted accessories
 - CABPT-R2** Twin outlets for roof mounted accessories.
 - SPOTP-F** Spotlamp preparation in front, max 280W
 - SPOTP-R** Spotlamp preparation on roof, max 280W
 - SPOTP-RF** Spotlamp preparation on cab roof and in cab front, max 2x280W
 - ROS-IL2** Preparation kit for illuminated roof sign with switch loose in cab, fit after registration
 - CSGN-GTR** "Globetrotter" headboard logo
 - HORN-F1S** Single tone Jericho air horn chassis mounted
 - HORN-R2S** Two roof mounted air horns
 - ANT-CBR** Roof mounted antenna for CB radio, single aerial
 - ACCBR-AP** Front, middle & rear roof mounted accessory brackets
 - ACCBR-F** Front roof mounted accessory bracket
 - ACCBR-FM** Front & middle roof mounted accessory brackets
 - ACCBR-FR** Front & rear roof mounted accessory brackets

Standard Equipment

Optional Equipment

For more detailed information about cab and powertrain equipment, please refer to separate specification sheets.

For all possible options and combinations of options please consult your Volvo sales contact who can create a specification to match your requirements using the Volvo Sales Support system (VSS).

The factory reserves the right to modify design and change equipment without previous notification. The specification can vary from country to country.

MODEL RANGE

FM 13 6x2 Platform - Low Tag - Full Air Suspension FM 62 TR3LA

- **ACCB-R-M** Middle roof mounted accessory bracket
- **ACCB-R-R** Rear roof mounted accessory bracket
- **ACCB-RM** Rear & middle roof mounted accessory brackets
- **REFS-CW** White cab conspicuity markings mounted on cab side
- **REFS-TW** White cab conspicuity markings by packed in cab
- **REFS-TY** Yellow cab conspicuity markings by packed in cab

SUPERSTRUCTURE PREPARATIONS

- **SW745-EE** Swapbody equipped with front stop block for wheelbase 4600 mm and body length 7150/7450 mm. Height 130 mm above frame.
- **SW745-FE** Swapbody equipped with front stop block for wheelbase 4800 mm and body length 7150/7450 mm. Height 130 mm above frame.
- **SW782-ME** Swapbody equipped with front stop block for wheelbase 4900 mm and body length 7150/7450/7820 mm. Height 130 mm above frame.
- **CROSSRE** Cross reinforcement for swapbody
- **SRWL-PK** Wiring preparation for side & rear work/reverse lamps on side of chassis and a three-position switch, maximum 280W
- **SWL-2FW** Two H3 70W white front chassis mounted (LH/RH side) working lamps and a 2-position switch (On/Off)
- **SWL-2RW** Two H3 70W white rear chassis mounted (LH/RH side) working lamps and a 2-position switch (On/Off)
- **SWL-4W** 4 H3 70W white front (2) & rear (2) chassis mtd (LH/RH side) working lamps & 2-pos switch (On/Off)
- **SWL-PK** Wiring preparation for side work/reverse lamps on side of chassis and a three-position switch, maximum 280W
- **WLC-H2A** Two H3/70W working lamps with amber coloured lens high mounted back of cab
- **WLC-H2W** Two H3/70W white working lamps high mounted on the back of cab
- **WLC-PKCH** Preparation kit (cables and switch) for cab mounted chassis working lamp
- **WLC-PKH** Preparation kit, cables and switch for high mounted working lamps back of cab
- **WLC-PKL** Preparation kit, cables and switch for low mounted working lamps back of cab
- **WLC-PKLH** Preparation kit - cables and switch for low and high mounted working lamps back of cab.
- **ECBB-BAS** Body builder electrical centre without body builder module
- **ECBB-HIG** Body builder electrical centre with body builder module
- **BBCHAS1** One 7-pole connector for Body builder interface
- **BBCHAS3** Three 7-pole connectors for Body builder interface
- **BEPR-T2** Body builder electrical software preparation for tipper with remote control
- **EXSTER** External steering control, with VDS and bodybuilder module
- **TD-BAS** Trailer detection WITHOUT LED sensing
- **TD-LED** Trailer detection with LED sensing
- **FRFS-BS** Frame rail free space on both sides to give space for crane legs or other equipment.
- **FBA-BTF** Lower front body attachments for torsionally flexible - platform body
- **FBA-BTSF** Lower front body attachments for torsionally semi-flexible body - box or curtainsider
- **HBA-FSFB** Holes for body attachments - flexible/semi-flexible body
- **HBA-SB** Holes for body attachments - stiff body
- **RBA-T2** Lower rear body attachments for helper frame
- **CRANEPK1** Crane plates mounted to frame, for cranes up to 10 tonne metre capacity
- **CRANEPK2** Crane plates mounted to frame, for cranes up to 20 tonne metre capacity
- **CRANEPK4** Crane plates mounted to frame, for cranes up to 40 tonne metre capacity
- **AUXL-SPK** Electrical preparation kit - wiring and switch for snow plough lights

- **TAILPRE2** Tail lift preparation kit, wireless remote operation
- **TAILPREP** Taillift preparation kit - cab switch and warning in driver display
- **AESW2** Two Body builder bistable electrical switches (marked AUX1 / AUX2)
- **AESW2PK** 2 Body builder bistable el.switches (marked AUX1/AUX2) and prep. for 4 more switches
- **AUXSW-4** Wiring for 4 extra switches (from Body builder electrical centre to switch positions)

DELIVERY SERVICES

- **TGW-4GWL** GSM/GPRS/4G modem, LTE & WLAN for telematics gateway
- **FMS-PK** Fleet Management System gateway

VOLVO

Volvo Truck Corporation

volvotrucks.com