

# MODEL RANGE

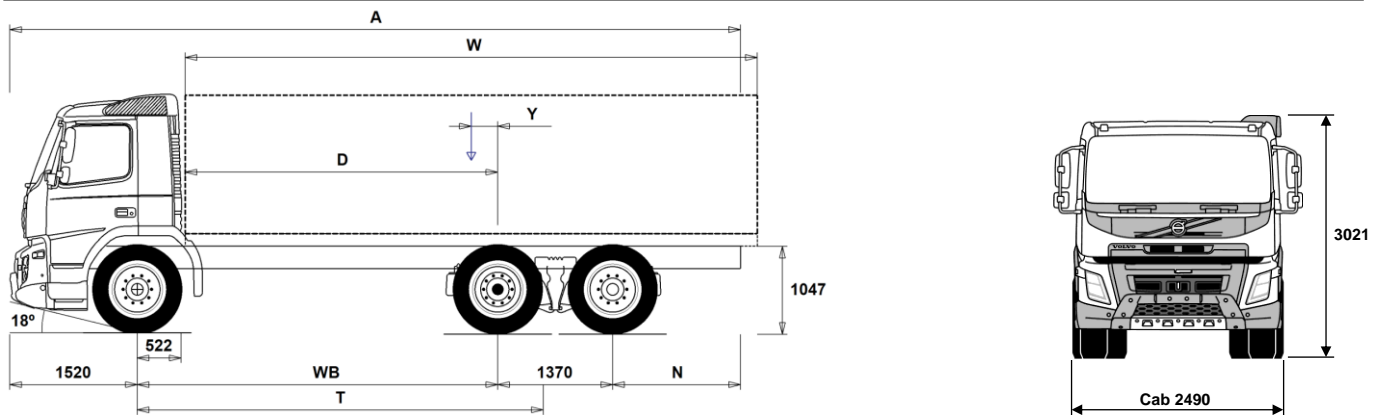

Volvo Trucks. Driving Progress

FMX D11 62 Rigid tag rear air FM 62 TR1HAX



## Chassis Dimensions [mm]

WB Wheelbase	3500	3700	3900	4300	4600	4800	4900	5200	5600	6000
A Overall Chassis Length	8315	8615	8915	9565	10015	10315	10465	10965	11065	10915
D Center of rear axle to front of body	2928	3128	3328	3728	4028	4228	4328	4628	5028	5428
N Rear Overhang (Min.)	1225	1225	1225	1225	1225	1225	1225	1225	1225	1225
N Rear Overhang (Max.)	1925	2025	2125	2375	2525	2625	2675	2875	2575	2025
T Theoretical Wheelbase	4041	4241	4441	4841	5141	5341	5441	5741	6141	6541
Y Center of Gravity for Payload (Min.)	42	72	101	158	197	226	241	285	331	374
Y Center of Gravity for Payload (Max.)	42	72	101	158	197	226	241	285	331	374
W Body Length (Min.)	5794	6135	6477	7162	7684	8027	8196	8710	9417	9908
W Body Length (Max.)	5794	6135	6477	7162	7684	8027	8196	8710	9417	9908

## Chassis Weights [kg]

Front Axle	4440	4440	4440	4445	4470	4475	4470	4475	4510	4550
Rear Bogie	2865	2890	2910	2975	3040	3060	3075	3115	3105	3070
Kerb Weight	7305	7330	7350	7420	7510	7535	7545	7590	7615	7620
Payload (including body, driver, fuel, etc.)	18795	18770	18750	18680	18590	18565	18555	18510	18485	18480

## Turning Diameter [mm]

Turning Circle Diameter Kerb to Kerb	14400	15000	15600	16800	17800	18400	18700	19600	20800	22000
Turning Circle Diameter Wall to Wall	15900	16500	17100	18300	19300	19900	20200	21100	22300	23500

## Plated Weights [kg]

Gross Vehicle Weight	26100
Gross Combination Weight	44000
Front Axle	7100
Rear Bogie	19000

## Design

## Important Notes

### Chassis Dimensions

Cab Height: +416 mm for CAB-HSLP, +554 mm for CAB-XHSL.  
Front Axle to Back of Cab: +424 mm for CAB-HSLP and CAB-SLP and CAB-XHSL.

D-measure includes a front clearance of 50 mm and for rigid trucks also a subframe of 100 mm.

Height can vary  $\pm 20$  mm for leaf and  $\pm 10$  mm for air suspension.

All dimensions are for unladen chassis and any tag axles down. Chassis height used: CHH-HIGH.

Rear overhang used for vehicle weight calculation is the maximum rear overhang (N Max.) for selected wheelbase.

Height change when chassis height CHH-MED, FRAME266: 0 mm.

Weight and dimensions are based upon the following tyres:

Front Axle Tyres:	315/80R22.5
Drive Axle Tyres:	315/80R22.5
Trailing/Pusher Axle Tyres:	315/80R22.5

**Chassis weight includes oil, water, AdBlue, 0 litres fuel and without driver. Kerb weight can vary  $\pm 3\%$ .**

Turning diameters are theoretically calculated. Tag axle used: TA-FIXED.

Legal weights can differ from country to country.

For more detailed weight information, including optional equipment weights, ask your Volvo sales contact to enter your specification into the Volvo Weight Information system (WIS).

Do NOT use this drawing for bodybuilding. Refer to Volvo Bodybuilder Instructions and chassis assembly drawing FM62TR1HAX.

# MODEL RANGE

FMX D11 62 Rigid tag rear air FM 62 TR1HAX

## Transport operation

- **RC-ROUGH** Rough road conditions.
  - Less than 95% of the driven distance on well maintained or less maintained surfaced roads.
  - and / or
  - In total not more than 5% of the driven distance on:
    - Very badly maintained surfaced roads.
    - Hard packed sand or gravel surface of very bad quality.
    - Washboards.
    - Soft unpaved surface.
    - Off-road.
- **RC-SMOOT** Smooth road conditions.
  - At least 95% of the driven distance on well maintained or less maintained surfaced roads.
  - Driving occurs on:
    - Badly maintained surfaced roads.
    - Hard packed sand or gravel surface of good or bad quality.
- **GARB-PRE** Garbage preparation
- **SWAPBODY** Swap body vehicle preparation
- **TIPP-PRE** Tipper vehicle preparation
- **UNIFORM** Basic platform vehicle

## Core components

- **CHH-HIGH** Chassis height high - approx. 1000 mm above ground level
- **CHH-MED** Chassis height medium - approx. 900 mm above ground level
- **TA-HYSBS** El. hydraulically steered tag axle with single wheels (two wheels on complete axle) and steering lock out at 38 km/h
- **TAG-FIXD** Fixed tag axle with twin wheels (4 wheels on complete axle)
- **TAG-FIXS** Fixed tag axle with single wheels (two wheels on complete axle)
- **TAG-SSTE** Self steered tag axle with single wheels (two wheels on complete axle)
- **RADT-GR** Rear air suspension, 2 axles - 1 driven / 1 tag
- **FMX-DAY** FMX Day cab
- **FMX-HSLP** FMX Globetrotter sleeper cab
- **FMX-SLP** FMX Sleeper cab
- **EU6SCR** Euro 6 emission level with Selective Catalytic Reduction (SCR), particulate filter and Exhaust Gas Recirculation (EGR)
- **D11K330** Diesel engine, 10.8 litre Euro 6 SCR + EGR (Diesel particulate filter), 330 hp, 1600 Nm
- **D11K380** Diesel engine, 10.8 litre Euro 6 SCR + EGR (Diesel particulate filter), 380 hp, 1800 Nm
- **D11K430** Diesel engine, 10.8 litre Euro 6 SCR + EGR (Diesel Particulate Filter), 430 hp, 2050 Nm
- **D11K460** Diesel engine, 10.8 litre Euro 6 SCR + EGR (Diesel Particulate Filter), 460 hp, 2200 Nm
- **EBR-EPG** Engine brake with exhaust pressure governor, EPG
- **EBR-EPGC** Volvo engine compression brake with exhaust pressure governor, EPG (for I-shift)
- **EBR-VEB** Volvo Engine Brake, VEB (compression brake with exhaust pressure governor, EPG)
- **AT2412F** I-Shift automated mechanical 12-speed gearbox without clutch pedal, max. engine torque 2400 Nm, max. permitted GCW 44000 kg.
- **AT2612F** I-Shift automated mechanical 12-speed gearbox without clutch pedal, max. engine torque 2600 Nm, max. permitted GCW 100000 kg.
- **ATO2612F** I-Shift automated mechanical 12-speed overdrive gearbox without clutch, max. engine torque 2600 Nm, max. permitted GCW 100000 kg. Suitable for hub reduction rear axles.
- **PT2106** Powertronic automatic 6-speed gearbox, max. engine torque 2100 Nm, max. permitted GCW 100000 kg
- **RSH1370F** Rear hub reduction solo axle - axle load 13 tonnes, GCW 70 tonnes, version F
- **RSS1344C** Rear single reduction solo axle - axle load 13 tonnes, GCW 44 tonnes, version C
- **RSS1344E** Rear single reduction solo axle - axle load 13 tonnes, GCW 44 tonnes, version E
- **RSS1352A** Rear single reduction solo axle - axle load 13 tonnes, GCW 52

■ Standard Equipment

□ Optional Equipment

For more detailed information about cab and powertrain equipment, please refer to separate specification sheets.

For all possible options and combinations of options please consult your Volvo sales contact who can create a specification to match your requirements using the Volvo Sales Support system (VSS).

The factory reserves the right to modify design and change equipment without previous notification. The specification can vary from country to country.

- **RSS1356** tonnes, version A  
Rear single reduction solo axle - axle load 13 tonnes, GCW 56 tonnes
- **RSS1370A** Rear single reduction solo axle - axle load 13 tonnes, GCW 70 tonnes, version A
- **RSS1370B** Rear single reduction solo axle - axle load 13 tonnes, GCW 70 tonnes, version B

## Packages

- **EDITION** Exterior Striping/Emblem. Model specific design on FH,FM,FH16 and FMX
- **DRIVEFM** Driving package FM
- **DRIVEFM+** Driving plus package FM
- **BEDFM** Bed resting package FM
- **AUDBAS** Audio basic. RDS radio with CD player, FM/AM antenna and speakers in dashboard & doors. Prepared for Dynafleet office internet portal support. High power audio system. RDS radio with CD player (also playing mp3/wma/wav files from CD), FM/AM antenna, speakers in dashboard & doors & sleeping compartment, integrated bluetooth phone and USB/Line inputs. Prepared for Dynafleet office internet portal support.
- **AUDHIG** Media package with infotainment. Prepared for Dynafleet office internet portal support.
- **MEDIA** Media package with infotainment. Prepared for both Dynafleet vehicle onboard support and for Dynafleet office internet portal support.
- **MEDIADF** Media package with infotainment and Navigation support and prepared for Dynafleet office internet portal support.
- **MEDIANAV** Media package with infotainment and Navigation support and prepared for Dynafleet vehicle onboard support and for Dynafleet office internet portal support.
- **MEDIANDF** Media package with infotainment and Navigation support and prepared for Dynafleet vehicle onboard support and for Dynafleet office internet portal support.
- **VISIX15** Visibility package FMX
- **ASAF15** Active safety package
- **ENOPT** Energy optimization package
- **ENOPT+** Energy optimization+ package
- **OFFRFMXD** Construction package for FMX day cab
- **OFFRFMXS** Construction package for FMX sleeper cabs
- **RCHAPAC1** Rigid chassis package
- Chassis**
- **FST-AIR** Front air suspension
- **FST-PAR** 2 leaf front parabolic suspension (normal stiffness)
- **FST-PAR3** 3 leaf front parabolic suspension (stiffer than normal)
- **FSLB-BAS** Front air suspension basic levelling stroke
- **FSLB-HI** Front air suspension high levelling stroke
- **FAL10.0** Front axle load 10.0 tonnes
- **FAL7.1** Front axle load 7.1 tonnes
- **FAL7.5** Front axle load 7.5 tonnes
- **FAL8.0** Front axle load 8.0 tonnes
- **FAL8.5** Front axle load 8.5 tonnes
- **FAL9.0** Front axle load 9.0 tonnes
- **FSTAB** Front stabilizer with normal stiffness
- **FSTAB2** Front stabilizer with medium high stiffness
- **FSTAB3** Front stiff stabilizer
- **RAL19** Rear axles load 19 tonnes
- **RAL20.5** Rear axles load 20.5 tonnes
- **RAL22.5** Rear axles load 22.5 tonnes
- **RAL23** Rear axles load 23 tonnes
- **RSTAB2** Rear stabilizer with medium stiffness
- **RSTAB3** Rear stiff stabilizer
- **RALIM105** First rear drive axle load limiter, 10.5 tonnes (speed controlled)
- **RALIM115** First rear drive axle load limiter, 11.5 tonnes (speed controlled)
- **RALIM95** First rear drive axle load limiter, 9.5 tonnes
- **ASF-DL1** Air suspension with 1 driving level
- **ASF-DL3** Air suspension with 3 driving levels

# MODEL RANGE

## FMX D11 62 Rigid tag rear air FM 62 TR1HAX

- ACTST-TO** Volvo Dynamic Steering (VDS) with extra pump and torque overlay
- ASFE-BAS** Volvo Dynamic Steering feature basic
- ASFE-PS** Volvo Dynamic Steering personal settings
- PSS-SING** Single power steering system
- PSP-FIX** Power steering pump with fixed displacement
- PSP-VAR** Power steering pump with variable displacement
- EBS-MED** EBS (Electronic Brake System) medium package:
  - ABS (Anti-lock Braking System)
  - Lining Wear Sensing (20 % left)
  - Lining Wear Control (incl. wear on the axle)
  - Brake Blending
  - Drag Torque Control
  - Diff Lock Synchronization
  - Diff lock Control
  - Brake Temperature Warning
  - External Brake Demand
  - Diagnosis Via Truck Electronic System
  - Traction Control System
  - Emergency Brake Assistance
  - Constant Wheel Brake Monitoring
  - Coupling Force Control
  - Automatic Parking Brake Activation
  - Lining Wear Analyses (calc of remaining mileage)
  - Hill Starting Assistance
  - EBS status monitoring via Truck Electronic System
- RST-AIR** Rear air suspension
- RST-AIR4** Rear air suspension with increased stiffness
- FBREG-E** Front axle regulating brake valve for EBS
- SUSPL-EC** Air suspension levelling with electronic control
- FRAME266** Frame rail section external height 266 mm
- FRAME300** Frame rail section external height 300 mm
- FST7070** Frame section thickness - web 7.0 mm / flange 7.0 mm
- FST8080** Frame section thickness - web 8.0 mm / flange 8.0 mm
- FIL-EEEB** Frame inner liner from end of engine end to end of bogie
- FIL-EEEF** Frame inner liner from end of engine end to end of frame
- FIL-TXEB** Frame inner liner from transmission cross member to end of bogie
- FIL-TXEF** Frame inner liner from transmission cross member to end of frame
- BBOX-L** Battery box on left hand side
- 2BAT210B** Gel batteries 2x210 Ah
- 2BATT170** Batteries 2x170 Ah
- 2BATT225** Batteries 2x225 Ah
- BATTAMP** Battery voltage and ampere gauge
- BATTIND** Battery voltage, ampere and battery status gauge with visual alerts
- ADR2** ADR adaptation - transportation of dangerous goods, 2 switches (1 inside cab in dashboard, 1 outside on cab back passenger side).
- MSWI-A** ADR main switch - ADR switch circuit shut down
- MSWI-C** Chassis main switch - battery box placed toggle switch circuit shut down
- MSWI-R** Remote controlled main switch - key fob operated circuit shut down
- R330A71** Right 330 litre aluminium 710 mm high D-shaped diesel tank. Usable volume is 97% of stated volume. Min volume 255l Max volume 885l
- UL-FUEL** Without left diesel tank Min volume 160l Max volume 730l
- ADTP-L** AdBlue tank on left hand side (for dual front axles between the axles)
- ADTP-R** AdBlue tank on right hand side
- ADB048** AdBlue tank usable volume 48 litres
- ADB064** AdBlue tank usable volume 64 litres
- ADB068** AdBlue tank usable volume 68 litres
- ADB090** AdBlue tank usable volume 90 litres
- ADB100** AdBlue tank usable volume 100 litres
- ADTC-BF** AdBlue tank cover painted in silver metallic
- FCAP-L** Lockable diesel and AdBlue tank caps
- FUFF-AS** Fuel filling anti-spillage device
- FUFF-ATS** Fuel filling anti-theft and anti-spillage devices
- ESH-LEFT** Horizontal muffler, left exhaust outlet
- ESH-REAR** Horizontal muffler, rear exhaust outlet
- ESH-VERT** Horizontal muffler, vertical exhaust outlet on right hand side
- ESV-VERT** Vertical muffler, vertical exhaust outlet on right hand side
- EXST-SSP** Bright polished vertical stainless steel exhaust top pipe
- EXST-ST** Aluminized steel vertical exhaust top pipe
- HS-NAR** Narrow Euro 6 muffler heat shield. Partly (due to heat release) reduced distance (moved inwards) to silencer. Makes better space for e.g. support legs.
- WHC-FIX2** Two fixed wheel chocks
- WHC-FOL2** 2 foldable wheel chocks
- WHCP-F** Wheel chock(s) in the front part of the vehicle.
  - TRACTOR, BBOX-L, Fold, 1/2 w chocks = Top of left side battery box
  - TRACTOR, BBOX-EF, Fold, 1/2 w chocks = Top of left side fuel tank
  - TRACTOR, BBOX-EF, Fix, 2 w chocks = Left frame front of fuel tank
  - RIGID, 1 front axle, Fold, 1/2 w chocks = Top of left side battery box
  - RIGID, 2 front axles, Fold, Frame free space, 2 wc = Top of left side battery box
  - RIGID, 2 front axles, Fix, W/o frame free space, 2 wc = Left frame behind 1st front wheel
- WHCP-M** Wheel chock(s) in the middle part of the vehicle
  - TRACTOR, BBOX-L, Fix, 1/2 w chocks = Left frame front of rear wheels
  - RIGID, 1 front axle, Fix, 1/2 w chocks = Left frame front of (or behind) rear wheels
- WHCP-R** Wheel chock(s) in the rear part of the vehicle
  - RIGID, 1 front axle, Fix, 1/2 w chocks = Left frame rear (or front) of rear wheels
- WHCP-T** Transport mounted wheel chock(s) in cab outer luggage compartment
- TB-L80** Left toolbox 800 mm length (mounting length 800 mm, real length 730 mm)
- TB-R80** Right toolbox 800 mm length (mounting length 800 mm, real length 730 mm)
- SUP-BAS** Standard aluminium bars for side underrun protection
- CHAIN-S** Snow chains
- HOOK-SC** Snow chain hooks. Rear mounted for tractors and side mounted in rear overhang for rigids. Two hooks on each side.
- TOWF-HD1** One heavy duty front towing device
- TOWMBRH** High mounted towing member, in centre of frame
- TOWMBRL1** Towing member, low mounted under the frame (position 1)
- TOWMBRL2** Towing member, low and forward mounted under the frame (position 2)
- TOWMBRL3** Towing member, low and far forward mounted under the frame, (position 3)
- TOWMBRM** Towing member, medium mounted in line with frame lower flange
- RFEC-L** Rear frame end, lower cut (for centre axle drawbar)
- RFEC-S** Rear frame end, straight cut (for regular platform applications)
- RFEC-U** Rear frame end, upper cut (for e.g. tipper, refuse and hooklift applications)

Standard Equipment                       Optional Equipment

For more detailed information about cab and powertrain equipment, please refer to separate specification sheets.

For all possible options and combinations of options please consult your Volvo sales contact who can create a specification to match your requirements using the Volvo Sales Support system (VSS).

The factory reserves the right to modify design and change equipment without previous notification. The specification can vary from country to country.

# MODEL RANGE

## FMX D11 62 Rigid tag rear air FM 62 TR1HAX

- C-RI4040** Towing coupling Ringfeder RF4040A G-150
  - C-RI4045** Towing coupling Ringfeder RF4045A G-150
  - C-RI5055** Towing coupling Ringfeder RF5055A G-150
  - C-RO400G** Towing coupling Rockinger 400 G-150
  - C-RO50** Towing coupling Rockinger 50 mm
  - C-VBG750** Towing coupling VBG 750V
  - C-VBG850** Towing coupling VBG 8500
  - TOWR-ONE** One rear towing device in frame end cross member
  - TREL-PK** Trailer electrical preparation kit (chassis/cab wiring)
  - TREL15** 15 pol electrical trailer connector (ADR certified)
  - TREL7-7** 2x7 pol (24N+24S) electrical trailer connectors (UADR)
  - TBC-DUO** Trailer brake connection, Duomatic
  - TBC-EC** Trailer brake connection, European Community
  - TRBR-STA** Stationary trailer brake control
  - TRB-STRE** Automatic low speed trailer brake activation (stretch brake) to avoid jack-knifing and to improve steerability
  - RUP-FOLD** Foldable aluminium rear underrun protection, EC approved
  - RUP-FOSL** Foldable and slidable aluminium rear underrun protection, EC approved
  - RFEND-B** Rear 3 piece fenders with anti-spray function (all rear axles)
  - RFEND-T** Transport mounted one-piece rear fenders
  - RFH-BAS** Optimal fender installation (rear and 2nd front axle) with regard to legal demands, wheel/tyre sizes, chassis height and fifth wheel height.
  - RFH-HIG** Highest fender installation (rear and 2nd front axle). Suitable for rough and very rough road conditions.
  - RFH-LOW** Lower fender installation (rear and 2nd front axle). Suitable only for smooth road conditions. Increased risk of fender top wear.
  - AUXATNK** Extra air tank
  - ATANK-AL** Aluminium air tanks
  - ATANK-ST** Steel air tanks
  - RESTS-W** Reflecting white stripes mounted on chassis side (underrun prot./toolbox/between fenders/overhang)
  - REST-RUP** Reflecting red stripes mounted on rear underrun protection
  - TL-LED** LED tail lamps (tail light, exterior marker light, brake light, hazard warning light, reverse light, rear fog light, licence plate light and reflector).
  - BLIGHT-E** Emergency brake light
  - FRACLOS** Frame end closing
  - RT-AL** Brushed aluminium rims with std holes (long stud fixing) on all axles
  - RT-ALDP** Dura-Bright polished aluminium rims with std holes (long stud fixing) on all axles
  - RT-ALDPD** Dura-Bright polished aluminium rims with countersunk holes (short stud fixing) on all axles
  - RT-ALDU** Brushed aluminium rims with countersunk holes (short stud fixing) on all axles
  - RT-STEEL** Steel rims on all axles
  - WCAP** Wheel caps
  - BRREC001** Bridgestone ECOPIA H - Fuel Tyre Recommendation 1
  - BRREC002** Bridgestone Ecopia H 002 Evo - Tyre recommendation 2
  - COREC002** Continental ECOPLUS HS3/HD3 - Fuel Tyre Recommendation 2
  - COREC003** FUEL EFFICIENCY CLASS A Continental Efficient Pro S/D - Fuel Tyre Recommendation 3
  - GYREC002** Good Year Fuelmax S Gen-2 Long Haul - Tyre Recommendation 2
  - GYREC003** Good Year Fuelmax S/(O)/D - Tyre Recommendation 3
  - GYREC004** Good Year Fuelmax S Gen2 - Tyre Recommendation 4
  - HAREC001** Hankook AL10+ E-Cube Max Long Haul Tire Recommendation 1
  - HAREC002** Hankook AL10+ E-Cube Long Haul Tire Recommendation 2
  - MIREC001** Michelin XFA2/X-LINE Energy - Fuel Tyre Recommendation 1
  - MIREC002** Michelin XZA2/X-LINE Energy - Fuel Tyre Recommendation 2
  - MIREC003** Michelin X-LINE Energy - Fuel Tyre Recommendation 3
  - MIREC004** FUEL EFFICIENCY CLASS A Michelin X Line Energy F/D2 - Fuel Tyre Recommendation 4
  - PIREC001** Pirelli FH:01 Proway - Tyre Recommendation 1
  - PIREC002** Pirelli FH:01 II - Tyre Recommendation 2
  - SPWT-D** Spare wheel with tyre equal to drive
  - SPWT-F** Spare wheel with tyre equal to front wheel
  - SWCP-LF** Spare wheel carrier on left side in front of rear axle
  - SWCP-R** Spare wheel carrier mounted behind rear axle and below frame
  - SWCP-T** Temporary spare wheel carrier. Spare wheel is transport mounted (strapped on top of the frame rails) with plastic stripes.
  - SWCP-TP** Spare wheel carrier transport mounted with the spare wheel on top of the frame rails
  - JACK-12T** Jack 12 tonnes
  - JACK-15T** Jack 15 tonnes
  - JACK-20T** Jack 20 tonnes
  - TOOL-BAS** Basic tools (combination screw driver, socket wrench)
  - TOOLKIT** Extended tool kit
  - INFLAHOS** Tyre inflation hose (18 metres) with nozzles in both ends
  - GAUGE-TP** Tyre pressure gauge
  - OBDEP-C** EU6 mandatory on board diagnostics, phase C regulations
  - OBDEP-D** EU6 mandatory on board diagnostics, phase D regulations
- ### Powertrain equipment
- TRAP-HD** Reinforced gearbox application. For manual gearboxes a heavy-duty nodular iron range housing. For I-shift gearboxes (2412 excl.) a reinforced gear shifting system.
  - PVT-BAS** Basic topography information, learning by GPS positioning
  - PVT-EXT** Extended topography information, learning by GPS positioning and centrally stored data
  - TP-BAS** I-shift City gear changing software
  - TP-CON** I-shift construction gear changing software
  - TP-DIST** I-shift distribution gear changing software
  - TP-LONG** I-shift long haul gear changing software
  - AMSO-AUT** I-shift manual gear shift available in automatic mode incl kickdown function
  - AVO-ENH** Enhanced I-shift software for construction and off road applications
  - APF-ENH** Enhanced I-shift PTO functions (Auto Neutral / Reverse Inhibit / Split Box Connection)
  - RET-TH** Retarder (incl cooler) for manual and I-shift gearboxes with oil as brake fluid
  - RET-TPT** Retarder for hydraulic gearbox
  - TC-HWO** Cooler for hydraulic gearboxes - water/oil
  - TC-MAOH2** Extra high performance cooler for manual/I-shift gearboxes - air/oil
  - TC-MWO** Basic performance cooler for manual/I-Shift gearboxes - water/oil
  - TC-MWOH2** High performance cooler for manual/I-Shift gearboxes - water/oil
  - 2COM1100** Dual cylinder air compressor 760 cc / 1100 l/min
  - 2COMP900** Dual cylinder air compressor 636 cc
  - CLU-AIRC** Air compressor clutch automatically declutched when not needed in order to save fuel
  - AIRIN-HI** High air intake
  - AIRIN-LO** Low air intake
  - ACL1ST-S** Air cleaner with additional filter element (primary + secondary)
  - 24AL110B** Alternator 110 Ampere
  - 24AL120B** Alternator 120 Ampere
  - 24AL150B** Alternator 150 Ampere

Standard Equipment       Optional Equipment

For more detailed information about cab and powertrain equipment, please refer to separate specification sheets.

For all possible options and combinations of options please consult your Volvo sales contact who can create a specification to match your requirements using the Volvo Sales Support system (VSS).

The factory reserves the right to modify design and change equipment without previous notification. The specification can vary from country to country.

# MODEL RANGE

## FMX D11 62 Rigid tag rear air FM 62 TR1HAX

- |  |   |
|--|---|
| <ul style="list-style-type: none"> <li><input type="checkbox"/> <b>CCV-C</b> Closed crankcase ventilation</li> <li><input type="checkbox"/> <b>PRIM-EL</b> Electrical priming pump for fast and easy bleeding of the fuel system</li> <li>■ <b>PRIM-MAN</b> Manual priming pump for fast and easy bleeding of the fuel system</li> <li><input type="checkbox"/> <b>AF-R</b> Hot fuel recirculation heated fuel filter</li> <li>■ <b>EST-AID</b> Engine start pre-heating element</li> <li><input type="checkbox"/> <b>220EBH15</b> Engine block heater, 220 volt, 1.5 kW</li> <li><input type="checkbox"/> <b>PTER-100</b> Rear engine mounted clutch independent power-take-off with flange connection (DIN 100 / ISO 7646)</li> <li><input type="checkbox"/> <b>PTER-DIN</b> Rear engine mounted clutch independent PTO with splined shaft groove (female) for a close coupled pump (DIN 5462 / ISO 7653)</li> <li><input type="checkbox"/> <b>PTER1400</b> Rear engine mounted clutch independent power-take-off with flange connection (SAE 1410 / ISO 7647)</li> <li><input type="checkbox"/> <b>HPE-F101</b> Rear engine mounted hydraulic pump F1-101, fixed displacement, single flow</li> <li><input type="checkbox"/> <b>HPE-F41</b> Rear engine mounted hydraulic pump F1-41, fixed displacement, single flow</li> <li><input type="checkbox"/> <b>HPE-F51</b> Rear engine mounted hydraulic pump F1-51, fixed displacement, single flow</li> <li><input type="checkbox"/> <b>HPE-F61</b> Rear engine mounted hydraulic pump F1-61, fixed displacement, single flow</li> <li><input type="checkbox"/> <b>HPE-F81</b> Rear engine mounted hydraulic pump F1-81, fixed displacement, single flow</li> <li><input type="checkbox"/> <b>HPE-T53</b> Rear engine mounted hydraulic pump F2-53/53, fixed displacement, twin flow</li> <li><input type="checkbox"/> <b>HPE-T70</b> Rear engine mounted hydraulic pump F2-70/35, fixed displacement, twin flow</li> <li><input type="checkbox"/> <b>HPE-V45</b> Rear engine mounted hydraulic pump VP1-45, variable displacement, single flow</li> <li><input type="checkbox"/> <b>HPE-V75</b> Rear engine mounted hydraulic pump VP1-75, variable displacement, single flow</li> <li><input type="checkbox"/> <b>PTPT-D</b> Automatic gearbox driven power take-off, 1 front/upper connection (DIN 5462 / ISO 7653) for plug-in pump (max. 850 Nm).</li> <li><input type="checkbox"/> <b>PTPT-F</b> Automatic gearbox driven Power take-off, 1 front/upper rear facing flange connection (SAE 1410 / ISO 7647) for propeller shaft (max. 850 Nm).</li> <li><input type="checkbox"/> <b>PTR-D</b> Mechanical gearbox driven low speed power take-off, 1 rear connection (DIN 5462 / ISO 7653) for plug-in pump (max. 1000 Nm).</li> <li><input type="checkbox"/> <b>PTR-DH</b> Mechanical gearbox driven high speed power take-off, 1 rear connection (DIN 5462 / ISO 7653) for plug-in pump (max. 600 Nm).</li> <li><input type="checkbox"/> <b>PTR-DM</b> Mechanical gearbox driven medium speed power take-off, 1 rear connection (DIN 5462 / ISO 7653) for plug-in pump (max. 600 Nm).</li> <li><input type="checkbox"/> <b>PTR-F</b> Mechanical gearbox driven low speed power take-off, 1 rear flange connection (SAE 1410 / ISO 7647) for propeller shaft (max. 1000 Nm).</li> <li><input type="checkbox"/> <b>PTR-FH</b> Mechanical gearbox driven high speed power take-off, 1 rear flange connection (SAE 1310 / ISO 7647) for propeller shaft (max. 600 Nm).</li> <li><input type="checkbox"/> <b>PTR-FL</b> Mechanical gearbox driven low speed power take-off, 1 rear flange connection (SAE 1310 / ISO 7647) for propeller shaft (max. 600 Nm).</li> <li><input type="checkbox"/> <b>PTRD-D</b> Mechanical gearbox driven high speed power take-off, 1 rear and 1 front connections (DIN 5462 / ISO 7653) for plug-in pumps (max. 870 Nm).</li> <li><input type="checkbox"/> <b>PTRD-D1</b> Mechanical gearbox driven high speed power take-off, 1 rear flange connection (SAE 1410 / ISO 7647) for propeller shaft / 1 front connection (DIN 5462 / ISO 7653) for plug-in pump (max. 870 Nm).</li> <li><input type="checkbox"/> <b>PTRD-D2</b> Mechanical gearbox driven power take-off, 2 rear flange (high-low speed) connections (SAE 1310/1410 / ISO 7647) for propeller shafts / 1 front (high speed) connection (DIN 5462 / ISO 7653) for plug-in pump (max. 870/1000 Nm).</li> <li><input type="checkbox"/> <b>PTRD-F</b> Mechanical gearbox driven high speed power take-off, 1 rear flange connection (SAE 1410 / ISO 7647) for propeller shaft (max. 870 Nm).</li> </ul> | <ul style="list-style-type: none"> <li><input type="checkbox"/> <b>HPG-F101</b> Gearbox mounted hydraulic pump F1-101, fixed displacement, single flow</li> <li><input type="checkbox"/> <b>HPG-F41</b> Gearbox mounted hydraulic pump F1-41, fixed displacement, single flow</li> <li><input type="checkbox"/> <b>HPG-F51</b> Gearbox mounted hydraulic pump F1-51, fixed displacement, single flow</li> <li><input type="checkbox"/> <b>HPG-F61</b> Gearbox mounted hydraulic pump F1-61, fixed displacement, single flow</li> <li><input type="checkbox"/> <b>HPG-F81</b> Gearbox mounted hydraulic pump F1-81, fixed displacement, single flow</li> <li><input type="checkbox"/> <b>EIDLESD</b> Engine idle shut down</li> </ul> <p><b>Cab Interior, Driving</b></p> <ul style="list-style-type: none"> <li>■ <b>STWPOS-L</b> Left hand drive</li> <li><input type="checkbox"/> <b>STWM-LE</b> Leather steering wheel</li> <li><input type="checkbox"/> <b>STGW-AD2</b> Mechanically adjustable steering wheel with neck tilt</li> <li>■ <b>STGW-ADJ</b> Mechanically adjustable steering wheel</li> <li><input type="checkbox"/> <b>AIRBAG</b> Airbag on driver side</li> <li><input type="checkbox"/> <b>INST-BAS</b> Basic level instrument cluster - 4 inch monochrome display 240x320 pix</li> <li><input type="checkbox"/> <b>DRC-AMII</b> Regeneration control of diesel filter particulates - auto initiation / manual on demand / manual inhibition</li> <li>■ <b>DRC-AUTO</b> Regeneration control of diesel filter particulates - fully automatic (in motion)</li> <li>■ <b>1DAYDIG2</b> Gen 2 one day digital tachograph, EC approved</li> <li><input type="checkbox"/> <b>1DAYDIGP</b> One day digital tachograph, EC approved + Prep Kit for TAS-DIG2</li> <li><input type="checkbox"/> <b>ARSL</b> Additional road speed limiter (switch in dashboard)</li> <li><input type="checkbox"/> <b>SPEED-DU</b> Dual speed limiter</li> <li><input type="checkbox"/> <b>CRUIS-E</b> Cruise control I-Cruise with controls in the steering wheel, I-Roll incl. Adding PVT-EXT/-MAP give I-See.</li> <li>■ <b>CRUISEC</b> Basic cruise control with controls in steering wheel</li> <li>■ <b>ESP-BAS1</b> Electronic Stability Program package intended for RIGID single vehicles or vehicle combinations with standard centre of gravity height when laden and for TRACTOR vehicle combinations with a single trailer or multiple trailers with ABS/EBS.</li> <li><input type="checkbox"/> <b>ESPC-RO</b> ESP (Electronic Stability Program) functionality control - Reduced / Off</li> <li><input type="checkbox"/> <b>HWSS-AC</b> Adaptive cruise control with forward collision warning</li> <li><input type="checkbox"/> <b>HWSS-ACB</b> Adaptive cruise control with forward collision warning (stationary and moving objects) and emergency braking. Using both radar and camera to collect info.</li> <li>■ <b>HWSS-FCB</b> Forward collision warning (stationary and moving objects) with emergency braking</li> <li>■ <b>LSS-DW</b> Lane keeping support - lane departure warning system</li> <li><input type="checkbox"/> <b>LCS</b> Lane Change Support</li> <li><input type="checkbox"/> <b>DAS-W</b> Driver Alert Support (drowsy driver warning)</li> <li><input type="checkbox"/> <b>RSENS-W</b> Wiper rain sensor</li> <li><input type="checkbox"/> <b>CU-ECC</b> Fully electrically controlled air conditioning with sun sensor</li> <li><input type="checkbox"/> <b>CU-ECC2</b> Fully electrically controlled air conditioning with sun sensor, mist sensor, air quality sensor and carbon filter</li> <li>■ <b>CU-MCC</b> Electrical manually controlled air conditioning</li> <li>■ <b>IMMOBIL</b> Immobiliser</li> <li><input type="checkbox"/> <b>ALARM-B</b> Burglar alarm - cab</li> <li><input type="checkbox"/> <b>ALARM-E</b> Burglar alarm - cab/body/trailer</li> <li><input type="checkbox"/> <b>ALCOLOCK</b> Alcolock</li> <li><input type="checkbox"/> <b>BUPMON</b> Back-up monitor including a 7 inch colour display integrated in dashboard, Waeco CCD-camera (delivered loose in cab) with a heated lens, motorised lens protection, 1 m pigtail cable (front) and 10 metres chassis cable for tractor /20 metres for rigid. Camera wirings not installed. Use PCA30081 for</li> </ul> |
|--|---|

■ Standard Equipment

Optional Equipment

For more detailed information about cab and powertrain equipment, please refer to separate specification sheets.

For all possible options and combinations of options please consult your Volvo sales contact who can create a specification to match your requirements using the Volvo Sales Support system (VSS).

The factory reserves the right to modify design and change equipment without previous notification. The specification can vary from country to country.

# MODEL RANGE

FMX D11 62 Rigid tag rear air FM 62 TR1HAX

- installation.
- PHONE-PK** Telephone preparation kit (antenna, antenna attachment, cable from antenna to radio shelf).
  - WLIFT-AD** Electrical window lift, auto up/down driver side; el operated on passenger side
  - WLIFT-EB** Electrical window lift.  
From the driver side both windows can be operated and from the passenger side the passenger side window can be operated.
  - ISUNS-BS** Manually manoeuvred side interior sun visor (roller blind type) on both sides
  - ISUNS-DS** Manually manoeuvred side interior sun visor (roller blind type) on driver side
  - ISUNF-B** Interior front plastic sun visors (driver and passenger side) without mirror on driver side
  - ISUNF-MD** Interior front plastic sun visors (driver and passenger side) with mirror on driver side
  - ISUNF-RE** Electrical textile interior sun visor (roller blind) integrated in front shelf
  - ISUNF-RM** Manual interior textile sun visor (roller-blind) integrated in front shelf
  - ADFS** Two extra DIN slots in front shelf (push/pull storage), 165x40x180 mm (WxHxD)
  - BUPALARM** Back-up alarm
  - RTOLL-PK** Preparation kit for road toll collect (GPS/GSM antenna and cables)
  - LOADIND** Load indicator with dashboard display.  
Measures axle pressures, load weight and total weight of truck and one trailer.
  - REMC-MF** Wireless remote control - multi functional
  - FIREXT2G** Fire extinguisher 2 kg, German decal
  - FIREXT3S** Fire extinguisher 3 kg, Swedish/English decal
  - WARNVEST** Warning vest. Fulfils European standard according to EN 471 class 2.
  - WARNTRI2** Two warning triangles
  - AIDKIT** First aid kit containing sticking plaster, washing and drying pads, compresses, elastic bandages, respiratory mask, gloves and scissors
  - AIDKIT1B** First aid kit containing sticking plaster, compresses, elastic bandages, gloves, scissors, triangular bandage, bandaging cloths, adhesive tape and rescue sheet (German requirements)
  - WARNLAMP** Portable warning lamp with batteries
  - LAMP-IN** Inspection lamp with 10 m cable
  - BULBKIT** Bulb and fuse kit
  - WRITEPAD** Writing pad with spring-loaded paper clip
- Cab Interior, Living**
- UPHTRI10** Seat upholstery with black embossed textile insert, black vinyl bolster and blue vinyl side insert & textile interior trim in matching grey/blue nuances
  - UPHTRI11** Seat upholstery with light grey embossed textile insert, raven metallic vinyl bolster and red vinyl side insert & vinyl/textile interior trim in matching skylark/grey/black nuances
  - UPHTRI12** Seat upholstery with blue soft textile insert, black vinyl bolster & textile interior trim in matching grey/black/blue colours
  - UPHTRI13** Seat upholstery with dark grey leather insert and black leather bolster & vinyl/textile interior trim in matching grey/black nuances
  - UPHTRI14** Seat with dark grey leather insert and black leather bolster & textile interior trim in matching grey and black colours
  - DST-CF1** Driver seat, comfort, suspended
  - DST-CF4** Driver seat, comfort, suspended, belt in seat
  - DST-CF5** Driver seat, comfort, suspended, belt in seat, electrically heated
  - DST-CF6** Driver seat, comfort, suspended, belt in seat, electrically heated, ventilated
  - SBD-RED** Red safety belts, passenge and driver seats
  - SBPRE-DS** Driver seat belt pretensioner
  - PST-BAS1** Passenger seat, basic, non suspended
  - PST-BENC** Bench passenger seat
  - PST-CF4** Passenger seat, comfort, suspended, belt in seat
  - PST-CF5** Passenger seat, comfort, suspended, belt in seat, electrically heated
  - PST-STD2** Passenger seat, regular, non suspended
  - PST-STD4** Passenger seat, regular, suspended
  - SBPRE-PS** Passenger seat belt pretensioner
  - ARM-DBPS** Two armrests on driver seat and one (outer) on passenger seat
  - ARMRE-BB** Two armrests on both driver and passenger seats
  - ARMRE-DB** Two armrests on driver seat
  - ARMRE-PB** Two armrests on passenger seat
  - ARMRE-PS** Single armrest (next to driver) on passenger seat
  - ARU-BAS** Vinyl armrest upholstery
  - ARU-LEA** Leather armrest upholstery
  - FMAT-RU2** Two black rubber floor mats with raised edges and an extended side (FMX)
  - FMAT-RUB** Two black rubber floor mats
  - FMAT-T2E** Two dark grey textile floor mats and two black rubber floor mats with an extended side (FMX)
  - FMAT-TX2** Two textile (dark grey on FH/FM, black on FH16) and two black rubber floor mats
  - LBK-RES** Lower fixed rest kit, foldable to rear wall
  - LBK70** Lower fixed bunk, not foldable - 2000x700 mm. Safety net included.
  - ULBK** Without lower bunk
  - MATL-FI** Mattress lower bunk - firm for over approx. 100 kg, pocket springs.
  - MATL-SF** Mattress lower bunk - semi-firm up to approx 100 kg, pocket springs.
  - OLMAT-BA** Overlay mattress protector, 28 mm thick black textile
  - OLMAT-PR** Overlay mattress protector, 35 mm thick black textile
  - TBK60F** Fixed top bunk 600x1900 mm, foldable up to 52 degrees to rear wall (depending on cab version and upper storage). Safety net included.
  - TBK70F** Fixed top bunk 700x1900 mm, foldable up to 52 degrees to rear wall (depending on cab version and upper storage). Safety net included.
  - PH-CAB2** Cab parking heater, 2 kW
  - PH-ENGCA** Engine and cab parking heater
  - PH-SS** Short stop heater
  - SLCP-BAS** Basic sleeper control panel (controlling interior light, parking heater, roof hatch and door lock)
  - SAFE** Key operated safe box under bed (FH) or at bed end (FM)
  - ETSB-F** Storage on engine tunnel - on front top
  - ETSB-FR** Storage on engine tunnel - on front top and at rear cab wall
  - ETSB-FRS** Storage on engine tunnel - on front top & at rear cab wall & storage immersed into tunnel on RH side
  - ETSB-FS** Storage on engine tunnel - on front top and storage immersed into tunnel on right hand side
  - ETSB-R** Fixed engine tunnel storage box at rear cab wall
  - ETSB-RS** Storage on engine tunnel - at rear cab wall and storage immersed into tunnel on right hand side
  - ETSB-S** Storage on engine tunnel - immersed into tunnel on right hand side
  - RUS-BAS** Rear cab upper storage 154 litres (300 mm high)
  - RUS-HIG** Rear cab upper storage 245 litres (440 mm high)
  - TABLE** Foldable and height adjustable table to be mounted to the lower bunk
  - REF-ICPK** Refrigerator preparation kit, engine tunnel mounted
- Standard Equipment       Optional Equipment

For more detailed information about cab and powertrain equipment, please refer to separate specification sheets.

For all possible options and combinations of options please consult your Volvo sales contact who can create a specification to match your requirements using the Volvo Sales Support system (VSS).

The factory reserves the right to modify design and change equipment without previous notification. The specification can vary from country to country.

# MODEL RANGE

FMX D11 62 Rigid tag rear air FM 62 TR1HAX

- REFR-RUS** 28 litre rear upper wall mounted refrigerator with dividers
  - MICRO-PK** Preparation kit for microwave oven (el. cables to front shelf)
  - BOTH-D** One 1.5 litre plastic soft-drink bottle holder under dashboard centre section
  - COFMA-PK** Preparation kit (24V) for coffee maker
  - INLI-BAS** Interior white light with smooth light transition at on/off, no dimming
  - INLI-NL** Interior white and red (night) light with smooth light transition at on/off
  - INLI-NLD** Interior white and red (night) light with smooth light transition at on/off and dimmer
  - ARL-FLEX** Two (driver and passenger side) reading lamps with flexible arms (snake lamps) and led lamps fitted on side walls
  - RH-EE** Without roof hatch, sky window / emergency exit (tinted glass)
  - RH-ETR** Roof hatch - Electrically operated / Tinted glass / Rear opening
  - RH-MSR** Roof hatch - Manually operated / Steel / Rear opening
  - RH-MTR** Roof hatch - Manually operated / Tinted glass / Rear opening
  - URH** Without roof hatch
  - SWIND-BS** Extra side window on both sides
  - SWIND-PS** Rear side window on passenger side
  - VANMIR** Vanity mirror in front shelf lid.  
In sleeper cab on passenger side and in high/extra high cabs in middle section of the front shelf.
  - AS-FUS** One extra shelf in each of the two front upper storage compartments.  
Only 1 shelf if microwave oven mounted in one of the two compartments.
  - INFOT-PK** Preparation kit (bracket, security straps, power cable, antenna cable and aux cable) for mounting of a television above driver door.
- Cab Exterior**
- PAICS-B** Basic painting in a lightning grey colour of cab surrounding parts (mirror housings, insteps, bumper and if fitted bumper spoiler and sun visor).  
If fitted roof air deflector, side air deflector and chassis fairings are always painted in cab colour.
  - GLAS-TIN** Tinted windows (front/side/rear)
  - AWIND-RF** Rear fixed window (without curtains)
  - DGLAS-L** Laminated door glass
  - LOCK-MAN** Manual door locking
  - LOCK-MRP** Manual door locking with internal remote control (from driver side) of passenger door
  - LOCK-REM** Central door locking with remote control
  - BUMP-HD** Heavy duty front bumper
  - GUARD-EH** Guard plate for cooling pipes and oil sump
  - SIDEH-B** Guide rail on day cab driver side
  - SIDSTP-R** Side ladder and guide rail on on day cab driver side
  - BUGNET** Radiator screen / Mosquito net (PVC coated fibreglass) in front of radiator
  - CTILTP-E** Electrical cab tilt pump
  - CTILTP-M** Manual cab tilt pump
  - FCABS-A** Air front cab suspension
  - FCABS-M** Mechanical cab suspension
  - RCABS-A** Air rear cab suspension
  - RCABS-M** Mechanical rear cab suspension
  - MIRCOMFX** El heated & operated robust main rear view mirrors, electrically heated wide angle mirrors (both sides).  
Close view mirror on passenger side.
  - MIRSTDX** Electrically heated robust main rear view mirrors and wide angle mirrors (both sides). Close view mirror on passenger side.
- AMIR-F20** Front close view mirror above windscreen, passenger side (radius 200 mm)
  - SUNV-H** Exterior transparent dark grey front sun visor
  - AD-ROOF** Roof air deflector. Design (length, height etc.) automatically calculated and varies depending on vehicle total height (chassis height, cab type, tyres etc).
  - AD-SIDEL** Long cab side air deflector
  - AD-SIDES** Short cab side air deflectors
  - HL-BAS2** Halogen H1 head lamps (heavy duty)
  - HL-BASIC** Halogen H7 head lamps
  - HL-BHID2** Bi-Xenon head lamps, high intensity discharged (heavy duty)
  - HL-CLEAN** High pressure headlamp cleaner
  - HLP-ST** Steel headlamp protection
  - HL-ADJ** Adjustable headlamps to adjust the height of the light beam
  - DRL-LED** V-shaped ("V-light") day running light (LED).  
Turned on low beam gives a dimmed "V-light".
  - ASL-RF2** Two Hella H11 70W spot lamps in sign box (one on each side of the Globetrotter sign)
  - ASL-RFPK** Preparation kit for two spot lamps in sign box
  - BEACO2F** Two front roof mounted amber rotating beacon warning lamps. Mounted on accessory bracket if ordered, otherwise on cab roof on both sides of the hatch.
  - BEACO2R** Two rear roof mounted (on accessory bracket) amber warning lamps.  
Rotating beacon lamps mounted on sleeper cab.  
Flashing LED lamps mounted on high/extra high sleeper cabs. Prepared wiring (switch and connected relay included) for warning lamps on cab roof.  
Max load 300 W.
  - BEACON-P** Four roof mounted amber warning lamps.  
2 front mounted (on accessory bracket if ordered) rotating beacon lamps.  
2 rear mounted (on mandatory accessory bracket) rotating beacon lamps on sleeper cab.  
2 rear mounted (on mandatory accessory bracket) flashing LED lamps on high/xhigh sleeper cabs.
  - BEACONA4** One front cab roof pass through on passenger side
  - CABPT-R1** Two front cab roof pass throughs, one on each side
  - SPOTP-F** Spotlamp preparation in cab front, max 280W
  - SPOTP-R** Spotlamp preparation on cab roof, max 280W
  - SPOTP-RF** Spotlamp preparation on cab roof and in cab front, max 2x280W
  - ROS-IL** Illuminated roof sign with switch in radio shelf. Switch for turning on/off.
  - ROS-IL2** Preparation kit for installing an illuminated roof sign\*. It includes a prerouted cable harness, a switch and LED-lamps. The switch is connected in the radio shelf middle section. Switch cap with icon, are enclosed in cab. Lamps in sign are mounted. The stripe in the Globetrotter window is selected via the cab sign variants
  - ROS-ILP** Wiring preparation kit (wires and switch) for cab sign or roof air deflector illumination
  - CSGN-FMX** FMX decal in the cab roof sign area
  - HORN-F1S** One front mounted (behind grille) single tone air horn, Jericho. Operated by steering wheel buttons.
  - HORN-R2S** Two roof mounted single tone chromed air horns. Operated by steering wheel buttons.
  - ANT-CBR** Right hand side roof mounted foldable antenna and cables for CB radio, single aerial.
  - ACCBR-AP** Front, middle & rear roof mounted accessory brackets
  - ACCBR-F** Front roof mounted accessory bracket
  - ACCBR-FM** Front & middle roof mounted accessory brackets
  - ACCBR-FR** Front & rear roof mounted accessory brackets
  - ACCBR-M** Middle roof mounted accessory bracket
  - ACCBR-R** Rear roof mounted accessory bracket
  - ACCBR-RM** Rear & middle roof mounted accessory brackets

Standard Equipment

Optional Equipment

For more detailed information about cab and powertrain equipment, please refer to separate specification sheets.

For all possible options and combinations of options please consult your Volvo sales contact who can create a specification to match your requirements using the Volvo Sales Support system (VSS).

The factory reserves the right to modify design and change equipment without previous notification. The specification can vary from country to country.

# MODEL RANGE

FMX D11 62 Rigid tag rear air FM 62 TR1HAX

- REFS-CW Reflecting white stripes mounted on cab side
- REFS-TW Reflecting white cab side stripes by-packed in cab
- REFS-TY Reflecting yellow cab side stripes by-packed in cab

## Superstructure preparations

- SW745-EE Swapbody equipped with front stop block for wheelbase 4600 mm, body length 7150/7450 mm and load carrier height 130 mm above frame
- SW745-FE Swapbody equipped with front stop block for wheelbase 4800 mm, body length 7150/7450 mm and load carrier height 130 mm above frame
- SW745-GE Swapbody equipped with front stop block for wheelbase 4600 mm, body length 7150/7450 mm and load carrier height 190 mm above frame
- SW745-HE Swapbody equipped with front stop block for wheelbase 4800 mm, body length 7150/7450 mm and load carrier height 190 mm above frame
- SW782-ME Swapbody equipped with front stop block for wheelbase 4900 mm, body length 7150/7450/7820 mm and load carrier height 130 mm above frame
- SW782-OE Swapbody equipped with front stop block for wheelbase 4900 mm, body length 7150/7450/7820 mm and load carrier height 190 mm above frame
- CROSSRE Cross reinforcement for swapbody
- SRWL-PK Wiring preparation for chassis mounted working lamps and a 3-position switch (On/Off/Reverse auto on). Max load 280W.
- SWL-2FW Two H3 70W white front chassis mounted (LH/RH side) working lamps and a 2-position switch (On/Off)
- SWL-2RW Two H3 70W white rear chassis mounted (LH/RH side) working lamps and a 2-position switch (On/Off)
- SWL-4W Four H3 70W white front (2) and rear (2) chassis mounted (LH/RH side) working lamps and a 2-position switch (On/Off)
- SWL-PK Wiring preparation for chassis mounted working lamps and a 2-position switch (On/Off). Max load 280W.
- WL-CHPK Preparation kit (switch and cable) for working lamp, max 2x70 W. Connector on chassis at gearbox.
- WLC-H2A Two H3/70W working lamps with amber coloured lens high mounted back of cab (switch incl).
- WLC-H2W Two H3/70W working lamps, white lens high mounted back of cab (switch incl).
- WLC-PKCH Preparation kit (cables and switch) for cab mounted chassis working lamp. Max load 280W.
- WLC-PKH Preparation kit (cables and switch) for high mounted working lamps back of cab (pass through in cab rear roof included). Max load 280W.
- WLC-PKL Preparation kit (cables and switch) for low mounted working lamps back of cab (pass through in cab rear wall included). Max load 280W.
- WLC-PKLH Preparation kit (cables and switch) for low and high mounted working lamps back of cab (pass throughs in rear wall and rear roof included). Max load 280W.
- ECBB-BAS Body builder electrical centre without any body builder module
- ECBB-HIG Body builder electrical centre with cab body builder module
- BBCHAS1 One 7-pole connector for Body builder interface. Wiring harness routed from the bodybuilder electrical distribution box inside the cab to a connection point inside the right frame rail beside the gearbox.
- BBCHAS3 Three 7-pole connectors for Body builder interface. Wiring harness routed from the bodybuilder electrical distribution box inside the cab to a connection point inside the right frame rail beside the gearbox.
- BEPR-T2 Body builder electrical software preparation for tipper with remote control
- EXSTER Support for external steering control via body builder module
- TD-BAS Trailer detection without LED sensor
- TD-LED Trailer detection with LED sensor
- FRFS-BS Frame rail free space on both sides to give space for crane legs or other equipment.

One front axle with day cab: 515/507 mm (L/R side).  
One front axle with long cab: 288/360 mm (L/R side).  
Two front axles with short cab: 632/572 mm (L/R side).  
Two front axles with long cab: 405/485 mm (L/R side).

- FBA-BTF Lower front body attachments for torsionally flexible platform body
- FBA-BTSF Lower front body attachments for torsionally semi-flexible body (van or curtainsider)
- HBA-FSFB Holes for body attachments, flexible/semi-flexible body
- HBA-SB Holes for body attachments, stiff body
- RBA-T2 Lower rear body attachments for helper frame
- CRANEPK1 Crane plates mounted to frame, interface for crane capacity up to 10 ton meter
- CRANEPK2 Crane plates mounted to frame, interface for crane capacity up to 20 ton meter
- CRANEPK4 Crane plates mounted to frame, interface for crane capacity up to 40 ton meter
- AUXL-SPK Electrical preparation kit (wiring and a switch in dashboard) for snow plough lights. Preparation for installation of additional headlights and additional turning indicators.
- TAILPRE2 Tail lift preparation kit, wireless remote operation
- TAILPREP Tail lift preparation kit, wire remote operation
- AESW2 Two Body builder bistable electrical switches (marked AUX1 / AUX2)
- AESW2PK Two Body builder bistable electrical switches (marked AUX1/AUX2) and in an empty 4-group preparation another four bistable switches with dummy switch caps
- AUXSW-4 Wiring for 4 extra hardwired switches (from Body builder electrical centre to switch positions)

## Services

- TGW-4GWL Telematics gateway with 4G modem
- TGW-PK Telematics gateway preparation kit
- FMS-PK Fleet Management System gateway, preparation kit
- DRUT My truck app gives the driver instant status information and control of the vehicle remotely from a smartphone or tablet. The variant enables the My truck app to connect to the vehicle.

# VOLVO

Volvo Truck Corporation

volvotrucks.com