

MODEL RANGE

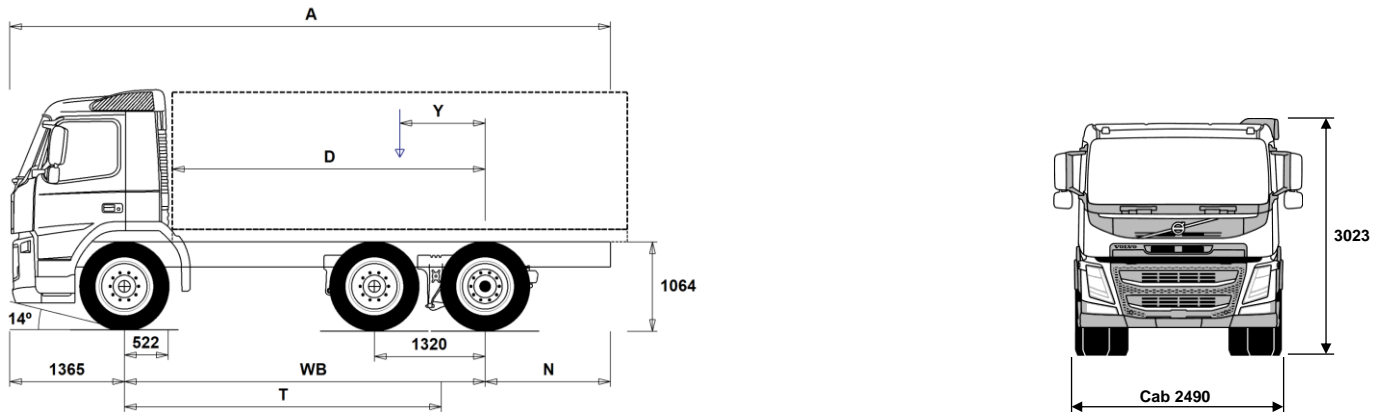

Volvo Trucks. Driving Progress

FM 13 6x2 Platform - Steered Pusher - Rear Air Suspension FM 62 PR3HA



Chassis Dimensions [mm]

WB Wheelbase	4300	4600	4900	5200	5600	6000
A Overall Chassis Length	7960	8560	8960	9460	10060	10660
D Center of rear axle to front of body	3728	4028	4328	4628	5028	5428
N Rear Overhang (Min.)	1395	1395	1395	1395	1395	1395
N Rear Overhang (Max.)	2295	2595	2695	2895	3095	3295
T Theoretical Wheelbase	3779	4079	4379	4679	5079	5479
Y Center of Gravity for Payload (Min.)	594	599	600	604	604	602
Y Center of Gravity for Payload (Max.)	1150	1201	1247	1297	1359	1420

Chassis Weights [kg]

Front Axle	4365	4370	4385	4385	4410	4435
Rear Bogie	2625	2670	2680	2720	2770	2805
Kerb Weight	6990	7040	7065	7105	7180	7240
Payload (including body, driver, fuel, etc.)	16660	16610	16585	16545	16470	16410

Turning Diameter [mm]

Turning Circle Diameter Kerb to Kerb	15900	16800	17800	18800	20000	21300
Turning Circle Diameter Wall to Wall	17300	18200	19200	20200	21400	22700

Plated Weights [kg]

	Plated	Design
Gross Vehicle Weight	23650	26100
Gross Combination Weight	44000	44000
Front Axle	7100	7100
Rear Bogie	19000	19000

Important Notes

Chassis Dimensions

Cab Height: +416 mm for CAB-HSLP, -169 mm for CAB-LSLP, +554 mm for CAB-XHSL.

Front Axle to Back of Cab: +424 mm for CAB-HSLP and CAB-SLP and CAB-XHSL, +418 mm for CAB-LSLP.

D-measure includes a front clearance of 50 mm and for rigid trucks also a subframe of 100 mm.

Height can vary ± 20 mm for leaf and ± 10 mm for air suspension.

All dimensions are for unladen chassis and any tag axles down.

Rear overhang used for vehicle weight calculation is the maximum rear overhang (N Max.) for selected wheelbase.

Weight and dimensions are based upon the following tyres:

Front Axle Tyres:	315/80R22.5
Drive Axle Tyres:	315/80R22.5
Trailing/Pusher Axle Tyres:	315/80R22.5

Chassis weight includes oil, water, AdBlue, 0 litres fuel and without driver. Kerb weight can vary $\pm 3\%$.

Turning diameters are theoretically calculated. Tag axle used: PA-HYDRS.

Legal weights can differ from country to country.

For more detailed weight information, including optional equipment weights, ask your Volvo sales contact to enter your specification into the Volvo Weight Information system (WIS).

Do NOT use this drawing for bodybuilding. Refer to Volvo Bodybuilder Instructions and chassis assembly drawing FM62PR3HA.

MODEL RANGE

FM 13 6x2 Platform - Steered Pusher - Rear Air Suspension FM 62 PR3HA

TRUCK USE

- GARB-PRE** Garbage preparation
- UNIFORM** Basic platform vehicle

CORE COMPONENTS

- CHH-HIGH** Chassis height high - N3 "On Road" chassis - For a specific loading height always check the unique BEP chassis drawing
- PU-EHYS** Electro-hydraulically steered pusher axle
- RAPD-GR** Rear air suspension, 2 axles - 1 pusher/1 driven
- FM-DAY** Day cab - with steel safety cage design
Designed and built to Swedish impact and ECE R29 regulations
- FM-HSLP** Globetrotter cab - with steel safety cage design
Designed and built to Swedish impact and ECE R29 regulations
- FM-LSLP** Low sleeper cab - with steel safety cage design
Designed and built to Swedish impact and ECE R29 regulations
- FM-SLP** Sleeper cab - with steel safety cage design
Designed and built to Swedish impact and ECE R29 regulations
- FM-XHSL** Globetrotter LXL cab - with steel safety cage design
Designed and built to Swedish impact and ECE R29 regulations
- EU6SCR** Emission level - Euro 6
- D13 420S** D13K420 12.8 litre engine developing 420hp at 14-1800rpm.
Peak torque 2100Nm at 860 -1400rpm.
- D13 460S** D13K460 12.8 litre engine developing 460hp at 14-1800rpm.
Peak torque 2300Nm at 900-1400rpm.
- D13 500S** D13K500 12.8l engine developing 500hp at 14-1800rpm.
Peak torque 2500Nm at 1000-1400rpm.
- D13K420** D13K420 - 420hp engine
- D13K460** D13K460 - 460hp engine
- D13K500** D13K500 - 500hp engine
- EBR-EPG** Exhaust brake controlled by steering column switch
- EBR-EPGC** Exhaust pressure governor for I shift gearbox
- EBR-VEB+** Volvo engine brake + and exhaust pressure governor, enhanced performance from additional exhaust rocker control. Retardation 375kW
- AT2412F** AT2412F 12-speed "I-shift" automated mechanical gearbox suitable for gross train weights up to 44tonne only refer to sales engineering when used in conjunction with a PTO
- AT2612F** AT2612F 12-speed "I-shift" automated mechanical gearbox suitable for gross train weights up to 60tonne only refer to sales engineering when used in conjunction with a PTO
- ATO2612F** ATO2612F 12-speed "I-shift" overdrive automated mechanical gearbox suitable for gross train weights up to 60tonne refer to sales engineering when used in conjunction with a PTO
- PT2606** Powertronic automatic 6-speed gearbox, max. engine torque 2600 Nm, max. permitted GCW 130000 kg
- RSH1370F** RSH1370F hub reduction rear axle with differential lock - design GCW 70 tonne
- RSS1344E** RSS1344E single reduction rear axle with differential lock - design GCW 44tonne
- RSS1352A** RSS1352A single reduction 13 tonne rear axle with differential lock - design GCW 52 tonne
- RSS1356** RSS1356 single reduction rear axle with differential lock - design GCW 56 tonne
- RSS1370A** RSS1370A single reduction 13 tonne rear axle with differential lock - design GCW 70 tonne
- RSS1370B** RSS1370B single reduction 13 tonne rear axle with differential lock - design GCW 70 tonne

PACKAGES

- LHFP-VE** Long Haul Fuel Economy driving package
- LHFP-VE+** Long Haul Fuel Economy plus driving package

- Standard Equipment
- Optional Equipment

For more detailed information about cab and powertrain equipment, please refer to separate specification sheets.

For all possible options and combinations of options please consult your Volvo sales contact who can create a specification to match your requirements using the Volvo Sales Support system (VSS).

The factory reserves the right to modify design and change equipment without previous notification. The specification can vary from country to country.

- DRIVEFM** Cab Package: Drive
 - DRIVEFM+** Cab Package: Drive +
 - BEDFM** One bed resting package
 - AUDHIG** High Power Audio system: RDS radio with CD player - also playing MP3/WMA files from CD -, with integrated bluetooth phone and USB/Line inputs. FM/AM antenna, speakers in dashboard, doors, and sleeping compartment.
 - MEDIA** AM/FM Bluetooth radio without CD player.
USB and Aux line inputs.
Speakers in dashboard, doors, and sleeping compartment.
7" touch screen with personal apps.
 - MEDIADF** AM/FM Bluetooth radio without CD player.
USB and Aux line inputs.
Speakers in dashboard, doors, and sleeping compartment.
7" touch screen with personal and professional apps.
Dynafleet vehicle on-board data display with office internet support.
 - MEDIANAV** AM/FM Bluetooth radio without CD player.
USB and Aux line inputs.
Speakers in dashboard, doors, and sleeping compartment.
7" touch screen with personal and professional apps.
Truck based satellite navigation (live updates not included)
 - MEDIANDF** AM/FM Bluetooth radio without CD player.
USB and Aux line inputs.
Speakers in dashboard, doors, and sleeping compartment.
7" touch screen with personal and professional apps.
Truck based satellite navigation (live updates not included)
Dynafleet vehicle on-board data display with office internet support.
 - VISI15** Visibility Package
 - VISI15+** Visibility Plus Package
 - ASAF15** Active Safety Package
 - RCHAPAC1** Chassis Package Rigid
- ### CHASSIS
- FST-AIR** Front suspension type - air
 - FST-PAR** Front suspension type - 2 leaf parabolic springs
 - FSL5-BAS** Front suspension levelling - basic stroke
 - FSL5-HI** Front suspension levelling - high stroke for demount operations - check with bodybuilder
 - FAL7.1** Front axle design capacity 7.1 tonnes
 - FAL7.5** Front axle design capacity 7.5 tonnes
 - FAL8.0** Front axle design capacity 8.0 tonnes - Ensure that you have checked the tyre load index
 - FAL8.5** Front axle design capacity 8.5 tonnes
 - FAL9.0** Front axle design capacity 9.0 tonnes - Ensure that you have checked the tyre load index
 - FSTAB** Front anti-roll bar
 - FSTAB2** Front anti-roll bar medium stiffness
 - FSTAB3** Front stiff anti-roll bar
 - RAL19** Rear bogie design capacity 19 tonnes
 - RSTAB3** Rear stiff anti-roll bar
 - RALIM115** Rear axle load limiter, 11.5 tonnes
 - ASF-DL1** Air suspension with 1 driving level
 - ACTST-TO** Volvo Dynamic Steering (VDS) with with extra electronic pump and torque overlay
 - ASFE-BAS** Active steering feature - Basic - Volvo Dynamic Steering only
 - ASFE-PS** Active steering feature - Volvo Dynamic Steering with personal settings
 - PSS-SING** Single power steering system
 - PSP-VAR** Power steering pump with variable displacement
 - EBS-MED** EBS medium package including "hill" hold function
 - FBREG-E** Front regulating brake valve, EBS
 - SUSPL-EC** Remote electronic control on wander-lead for air suspension

MODEL RANGE

FM 13 6x2 Platform - Steered Pusher - Rear Air Suspension FM 62 PR3HA

	levelling		
■ FRAME300	Frame rail section external height 300 mm	■ TOWF-NO1	One front towing device
□ FST7070	Frame thickness - web and flange 7.0mm	□ TOWF-NO2	Two front towing devices
■ FST8080	Frame thickness - web and flange 8.0mm	□ TOWMBRH	Towing member, high mounted in centre of frame, D = 190
□ FIL-EEEB	Inner liner from end of engine to end of bogie	□ TOWMBRL1	Towing member, low mounted under the frame
□ FIL-EEEF	Inner liner from end of engine to end of frame	□ TOWMBRL2	Towing member, low and forward mounted under the frame
□ FIL-FBEB	Inner liner over rear bogie	□ TOWMBRL3	Towing member, low and far forward mounted under the frame
□ FIL-FBEF	Inner liner from front of bogie to end of frame	□ TOWMBRM	Towing member, medium mounted in line with frame lower flange
□ FIL-TXEB	Inner liner from gearbox member to end of bogie	□ RFEC-L	Rear frame end, lower flange cut for centre axle drawbar.
□ FIL-TXEF	Inner liner from gearbox member to end of frame	■ RFEC-S	Rear frame end, straight cut for regular platform applications
■ BBOX-L	Battery box located on left hand side	□ RFEC-U	Rear frame end, upper cut for tipper applications.
□ BATS-D	Dual energy battery system - 2 living batteries and 2 starter batteries.	□ C-RI4040	Towing coupling, Ringfeder 4040 G-150
■ BATS-S	Single energy battery system (2 batteries)	□ C-RI5055	Towing coupling, Ringfeder 5055 G-150
□ 2BAT210B	2 x 210 Ah capacity Gel batteries	□ C-RO400G	Towing coupling, Rockinger 400 G-150 for 40mm eyes
■ 2BATT170	2 x 170 Ah capacity batteries	□ C-RO50	Rockinger RO 50 50mm for centre axle trailer
□ 2BATT225	2 x 225 Ah capacity batteries	□ TOWR-ONE	Towing hitch attached to rear crossmember
■ BATTAMP	Battery voltage and ampere gauge	■ TREL-PK	Trailer electrical preparation kit - chassis/cab wiring
□ BATTIND	Battery charge indication	□ TREL14	Single 14 pole electrical trailer connector
□ ADR2	ADR package for transportation of dangerous goods on road (Note does NOT include safe loading pass package if required this is quoted separately)	□ TREL15	Single 15 pole electrical trailer connector - ADR certified
□ MSWI-A	Main switch - ADR switch circuit shut down	□ TREL7	7 pole - 24N trailer electrical suzie
■ MSWI-C	Main switch - Chassis mounted toggle switch by battery box	□ TREL7-7	24N and 24S trailer electrical suzies
□ MSWI-R	Main switch - Key fob operated remote controlled	□ TBC-DUO	Duomatic type air line connectors
■ R330A71	Right aluminium 710 mm D-shaped fuel tank, 330 litres volume Min volume 150l Max volume 810l	□ TBC-EC	Palm coupling type air line connectors
■ UL-FUEL	Without left fuel tank Min volume 160l Max volume 690l	□ TRBR-HCF	Full pressure hand controlled trailer brake
□ ADTP-L	AdBlue tank on left hand side	□ TRBR-STA	Stationary trailer brake control
■ ADTP-R	AdBlue tank on right hand side	□ TRB-STRE	Stretch Brake - Automatic low speed trailer brake activation to avoid jack-knifing and improve steerability
□ ADB048	AdBlue tank usable volume 48 litres	□ RUP-FOLD	Folding EC approved aluminium rear underrun
■ ADB064	AdBlue tank usable volume 64 litres	□ RUP-FOSL	Folding & sliding EC approved aluminium rear underrun
□ ADB068	AdBlue tank usable volume 68 litres	□ RFEND-B	Three piece EC approved rear mud wings and spray flaps
□ ADB090	AdBlue tank usable volume 90 litres	□ RFEND-T	Rear mud wings, transport mounted
□ ADB100	AdBlue tank usable volume 100 litres	■ RFH-BAS	Basic rear wing height
□ ADTC-BF	AdBlue tank cover with satin alloy look decorative cover	□ RFH-HIG	High rear wing height - higher wing tops
■ FCAP-L	Locking fuel filler cap	□ RFH-LOW	Lower rear wing height - shallower wing tops
■ FUFF-AS	Fuel filling anti-spillage device	□ ATANK-AL	Aluminium air tanks
□ FUFF-ATS	Fuel filling anti-theft and anti-spillage devices	■ ATANK-ST	Steel air tanks
□ ESH-LEFT	Horizontal silencer, left exhaust outlet	■ TL-LED	Rear lights LED
■ ESH-REAR	Horizontal silencer, rear exhaust outlet	□ BLIGHT-E	Emergency brake light
□ ESH-RIGH	Horizontal silencer, right exhaust outlet		
□ ESH-VERT	Horizontal silencer, vertical exhaust outlet		
□ EXST-SSP	Stainless steel exhaust stack - NOT polished		
□ EXST-ST	Steel exhaust stack		
□ HS-NAR	Narrow heat shield		
□ WHC-FIX2	Two fixed wheel chocks		
□ WHC-FOL2	Two foldable wheel chocks		
□ WHCP-F	Wheel chock(s) stored in the front part of the vehicle		
□ WHCP-M	Wheel chock(s) stored in the middle part of the vehicle		
□ WHCP-R	Wheel chock(s) stored in the rear part of the vehicle		
□ WHCP-T	Transport mounted wheel chock(s) stored in cab outer luggage locker		
□ TB-R80	Toolbox 800 mm, right side		
□ SUP-BAS	EC approved chassis side guards		
□ CHAIN-S	Snow chains		
□ HOOK-SC	Snow chain hooks		
■ Standard Equipment		□ Optional Equipment	

For more detailed information about cab and powertrain equipment, please refer to separate specification sheets.

For all possible options and combinations of options please consult your Volvo sales contact who can create a specification to match your requirements using the Volvo Sales Support system (VSS).

The factory reserves the right to modify design and change equipment without previous notification. The specification can vary from country to country.

MODEL RANGE

FM 13 6x2 Platform - Steered Pusher - Rear Air Suspension FM 62 PR3HA

- HAREC002** Hankook AL10+ E-Cube Long Haul Tyre - Energy rating B with wide single
 - MIREC001** Michelin XFA2/X-LINE Energy - Fuel tyre Recommendation 1
 - MIREC002** Michelin XZA2/X-LINE Energy - Fuel tyre Recommendation 2
 - MIREC003** Michelin X-LINE Energy - Fuel tyre Recommendation 3
 - MIREC004** Michelin X Line Energy F/D2 - Energy rating A
 - PIREC001** Pirelli FH:01 Proway - Long Haul Tyre - Energy rating B
 - PIREC002** Pirelli FH:01 II Long Haul Tyre - Energy rating B with wide single
 - SPWT-D** Spare wheel & tyre with rear tyre pattern
 - SPWT-F** Spare wheel & tyre with front tyre pattern
 - SWCP-LF** Spare wheel carrier on left side of chassis ahead of rear axle
 - SWCP-R** Rear mounted spare wheel carrier
 - SWCP-T** Spare wheel supplied temporarily strapped to chassis
 - SWCP-TP** Temporary spare wheel carrier on top of chassis frame
 - JACK-12T** 12 tonne bottle jack
 - JACK-15T** 15 tonne bottle jack
 - JACK-20T** 20 tonne bottle jack
 - TOOL-BAS** Basic Toolkit
 - TOOLKIT** Complete tool kit
 - INFLAHOS** Tyre inflation hose
 - GAUGE-TP** Tyre pressure gauge
- ### DRIVELINE EQUIPMENT
- TRAP-HD** Reinforced gearbox application
 - TP-CON** Construction Package
 - TP-DIST** Distribution Package
 - TP-LONG** Long Haul Package
 - AMSO-AUT** Enhanced I-shift software with manual shift available in auto mode and kickdown facility on accelerator pedal
 - AVO-ENH** Enhanced software for off road driveability and starting
 - APF-ENH** I-shift enhanced PTO functions
 - RET-TH** Gearbox mounted retarder
 - RET-TPT** Hydraulic Retarder for Powertronic gearbox
 - TC-HWO** Automatic gearbox oil cooler - water to oil
 - TC-MAOH2** Extra high performance transmission oil cooler - air to oil with front mounted radiator
 - TC-MWO** Basic transmission oil cooler - water to oil
 - 2COM1100** Two cylinder, air compressor, 1100 litres per minute
 - 2COMP900** Two cylinder, air compressor, 900 litres per minute
 - CLU-AIRC** Clutchable air compressor
 - AIRIN-HI** Roof mounted air intake behind cab on left hand side
 - AIRIN-LO** Low level air intake behind cab on left hand side
 - ACL1ST-S** Two stage air filter
 - 24AL110B** 110 amp alternator
 - 24AL120B** 120 amp alternator
 - 24AL150B** 150 amp alternator
 - CCV-C** Closed crankcase engine ventilation
 - CCV-O** Open crankcase engine breather
 - CCV-OX** Closed crankcase ventilation for cold markets
 - PRIM-EL** Electrical priming pump
 - PRIM-MAN** Manual priming pump
 - FUEQ-EH** Fuel line electric heater
 - AF-R** Hot fuel recirculation heated fuel filter
 - FUEFE2LW** Large engine mounted dual fuel filter with water separator
 - FUEFE2SW** Small engine mounted dual fuel filter with water separator
 - EST-AID** Air inlet manifold starting heater element
 - 220EBH15** 220V/1.5Kw electric engine block heater
 - PTER-100** Rear engine mounted power-take-off with DIN 100 / ISO 7646 flange
 - PTER-DIN** Rear engine mounted PTO with DIN5462 (female) splined shaft for a close coupled pump.
 - PTER1400** Models with 3 steering axles will use this to drive the steering pump (AUXPSP)
 - HPE-F101** Parker F1-101, engine mounted, fixed displacement, single flow, engine mounted hydraulic pump
 - HPE-F41** Parker F1-41, engine mounted, fixed displacement, single flow, engine mounted hydraulic pump
 - HPE-F51** Parker F1-51, engine mounted, fixed displacement, single flow, engine mounted hydraulic pump
 - HPE-F61** Parker F1-61, engine mounted, fixed displacement, single flow, engine mounted hydraulic pump
 - HPE-F81** Parker F1-81, engine mounted, fixed displacement, single flow, engine mounted hydraulic pump
 - HPE-T53** Parker F2-53/53, engine mounted, Fixed displacement, Twin flow engine mounted hydraulic pump
 - HPE-T70** Parker F2-70/35, engine mounted, Fixed displacement, Twin flow engine mounted hydraulic pump
 - HPE-V45** Parker VP1-45, variable displacement, single flow, engine mounted hydraulic pump
 - HPE-V75** Parker VP1-75, variable displacement, single flow, engine mounted hydraulic pump
 - PTPT-D** Powertronic PTO, 1 front/upper DIN connection for plug-in pump (max. 850 Nm)
 - PTPT-F** Powertronic PTO, 1 front/upper rear facing SAE flange conn. for prop shaft (max.850 Nm)
 - PTR-D** Gearbox PTO for plug-in pump, 0.71xeng speed
 - PTR-DH** Gearbox driven high speed PTO for one plug-in hydraulic pump
 - PTR-DM** Gearbox driven medium speed PTO for one plug-in hydraulic pump
 - PTR-F** Gearbox driven PTO with rear flange connection
 - PTR-FH** Gearbox driven high speed PTO with SAE drive flange
 - PTR-FL** Gearbox driven low speed PTO with SAE drive flange
 - PTRD-D** Gearbox driven HIGH SPEED PTO for two plug-in hydraulic pumps
 - PTRD-D1** PTRD-D1 Gearbox driven HIGH SPEED PTO (1 SAE flange & 1 plug-in hydraulic pump)
 - PTRD-D2** Gearbox driven HIGH SPEED PTO (2 SAE flanges & 1 plug-in hyd pump)
 - PTRD-F** PTO with 1 DIN + 1 flange connection rear, manual gearbox
 - HPG-F101** Parker F1-101 gearbox mounted, fixed displacement, single flow, hydraulic pump
 - HPG-F41** Parker F1-41 gearbox mounted, fixed displacement, single flow, hydraulic pump
 - HPG-F51** Parker F1-51 gearbox mounted, fixed displacement, single flow, hydraulic pump
 - HPG-F61** Parker F1-61 gearbox mounted, fixed displacement, single flow, hydraulic pump
 - HPG-F81** Parker F1-81 gearbox mounted, fixed displacement, single flow, hydraulic pump
 - EIDLESD** Engine idle shut down
 - DTRI-PER** Dashboard in darker peregrine greyish brown. Steering wheel grey and door panels in light beige for FH and black for FH16.
 - STWPOS-R** RIGHT HAND DRIVE
 - STWM-LE** Leather steering wheel
 - STGW-AD2** Adjustable steering wheel with neck tilt
 - STGW-ADJ** Adjustable steering wheel
 - AIRBAG** SRS Driver's air bag
 - DRC-AMII** DPF Regeneration control switch - for manual and switching off regeneration
 - 1DAYDIG2** Continental VDO DTCO 4.0 smart tachograph
This tachograph can ONLY offer remote download if the option of Dynafleet or an FMS gateway has been specified with this order.
 - 1DAYDIGP** Continental VDO DTCO 3.0 digital tachograph
For vehicles with long lead time - this includes prep kit for the retrofit of DTCO 4.0 tachograph.

Standard Equipment Optional Equipment

For more detailed information about cab and powertrain equipment, please refer to separate specification sheets.

For all possible options and combinations of options please consult your Volvo sales contact who can create a specification to match your requirements using the Volvo Sales Support system (VSS).

The factory reserves the right to modify design and change equipment without previous notification. The specification can vary from country to country.

MODEL RANGE

FM 13 6x2 Platform - Steered Pusher - Rear Air Suspension FM 62 PR3HA

	For updating to new legal demand for trick registration from 15th June 2019. This tachograph can ONLY offer remote download if the option of Dynafleet or an FMS gateway has been specified with this order.	<input type="checkbox"/> LAMP-IN	Inspection lamp
<input type="checkbox"/> ARSL	Additional road speed limit - switch in dashboard	<input type="checkbox"/> BULBKIT	Bulb and fuse kit
<input type="checkbox"/> SPEED-DU	Dual speed limiter	<input type="checkbox"/> WRITEPAD	Writing pad
<input type="checkbox"/> CRUIS-E	Eco cruise control (with eco-roll and I-cruise, controls in steering wheel)	<input type="checkbox"/> UPHTRI10	Seats: Black embossed textile insert with light grey sides, black vinyl side bolster with blue vinyl side insert. Interior trim: Raven black bunk and curtains & blue textile side walls
<input checked="" type="checkbox"/> CRUISEC	Cruise control, standard	<input type="checkbox"/> UPHTRI11	Seats: Light grey embossed textile insert, black raven metallic vinyl bolster with red vinyl side insert. Interior trim: Raven black bunk and curtains & grey vinyl side walls
<input checked="" type="checkbox"/> ESP-BAS1	Electronic Stability Control	<input type="checkbox"/> UPHTRI12	Seats: Blue soft textile insert, black vinyl bolster. Interior trim: Raven black bunk and curtains & blue textile side walls
<input type="checkbox"/> ESPC-RO	ESP (Electronic Stability Program) functionality control - Reduced / Off	<input type="checkbox"/> UPHTRI13	Seats: Dark grey leather insert and black leather bolster. Interior trim: Raven black bunk and curtains & grey vinyl side walls
<input type="checkbox"/> HWSS-ACB	Adaptive cruise control ACC with forward collision warning and AEBs advanced emergency brake system	<input type="checkbox"/> UPHTRI14	Seat: Dark grey leather insert and black leather bolster. Interior trim: Raven black bunk and curtains & blue textile side walls
<input checked="" type="checkbox"/> HWSS-FCB	Forward collision warning with AEBs advanced emergency brake system	<input checked="" type="checkbox"/> DST-CF4	Driver seat, comfort, suspended, belt in seat
<input checked="" type="checkbox"/> LSS-DW	Lane departure-warning system	<input type="checkbox"/> DST-CF5	Driver seat, comfort, suspended, belt in seat, electrically heated
<input type="checkbox"/> LCS	Lane change support	<input type="checkbox"/> DST-CF6	Driver seat, comfort, suspended, belt in seat, electrically heated, ventilated
<input type="checkbox"/> DAS-W	Driver Alert Support system	<input type="checkbox"/> SBD-RED	Red seat belts
<input type="checkbox"/> RSSENS-W	Rain sensing windscreen wipers	<input type="checkbox"/> SBPRE-DS	Driver seat belt pretensioner
<input type="checkbox"/> CU-ECC	Electrically controlled air conditioning with sun sensor	<input checked="" type="checkbox"/> PST-BAS1	Passenger seat - Fixed non suspended fold up with seatbelt mounted in cab
<input type="checkbox"/> CU-ECC2	Electrically controlled air conditioning with sun sensor, mist sensor, air quality sensor and carbon filter	<input type="checkbox"/> PST-BENC	Bench passenger seat
<input checked="" type="checkbox"/> CU-MCC	Climate unit with manual controlled air conditioning	<input type="checkbox"/> PST-CF4	Passenger seat - Comfort suspended with seatbelt mounted in seat
<input checked="" type="checkbox"/> IMMOBIL	Thatcham H2 approved immobiliser	<input type="checkbox"/> PST-CF5	Passenger seat - Comfort suspended & heated with seatbelt mounted in seat
<input type="checkbox"/> ALARM-B	Thatcham H1 approved vehicle alarm - Cab only	<input type="checkbox"/> PST-STD2	Passenger seat - Fixed non suspended with seatbelt mounted in cab
<input type="checkbox"/> ALARM-E	Enhanced vehicle alarm - Thatcham H1 approved - Cab plus external sensor for body/trailer	<input type="checkbox"/> PST-STD4	Passenger seat - Standard suspended with seatbelt mounted in cab
<input type="checkbox"/> ALCOLOCK	Alcolock	<input type="checkbox"/> SBPRE-PS	Passenger seat belt pretensioner
<input type="checkbox"/> BUPMON	Back up monitor with built in 7" screen on dash and one colour camera supplied loose for fitment by bodybuilder. Can accommodate up to 4 cameras for TfL Safe Scheme, CLOCS and FORS.	<input type="checkbox"/> ARM-DBPS	Two armrests on driver seat and one (outer) on passenger seat
<input type="checkbox"/> PHONE-PK	Telephone preparation kit (antenna, antenna attachm. cable incl.)	<input type="checkbox"/> ARMRE-BB	Two armrests on both driver and passenger seat.
<input type="checkbox"/> WLIFT-AD	Electrical window lift, automatic up/down driver side	<input type="checkbox"/> ARMRE-DB	Two armrests, on driver seat only
<input checked="" type="checkbox"/> WLIFT-EB	Electrical window lift	<input type="checkbox"/> ARMRE-PB	Two armrests, on passenger seat only
<input type="checkbox"/> WLIFT-ME	Mechanical window lift	<input type="checkbox"/> ARMRE-PS	Single armrest (next to driver) on passenger seat
<input type="checkbox"/> ISUNS-BS	Side interior sun visor on both sides	<input type="checkbox"/> ARU-BAS	Vinyl upholstered armrest
<input checked="" type="checkbox"/> ISUNS-DS	Driver's side interior sun visor	<input type="checkbox"/> ARU-LEA	Leather upholstered armrest
<input checked="" type="checkbox"/> ISUNF-B	Interior front sun visor without mirror	<input checked="" type="checkbox"/> FMAT-RUB	Rubber floor mats
<input type="checkbox"/> ISUNF-MD	Interior front sun visor with mirror on driver side	<input type="checkbox"/> FMAT-TX2	Textile and rubber floor mats
<input type="checkbox"/> ISUNF-RE	Electrically operated textile interior sun blind	<input type="checkbox"/> LBK-RES	Foldable rest bunk
<input type="checkbox"/> ISUNF-RM	Manually operated textile interior sun blind	<input type="checkbox"/> LBK70	Lower bunk 700 x2000 mm, fixed
<input type="checkbox"/> ADFS	Two extra DIN slots in front shelf - can be fitted with card or drawer available as an accessory	<input checked="" type="checkbox"/> ULBK	Without lower bunk
<input checked="" type="checkbox"/> BUPALARM	Reverse alarm	<input type="checkbox"/> MATL-FI	Firm lower bunk pocket sprung mattress
<input type="checkbox"/> RTOLL-PK	Road toll PREPARATION kit for trucks operating with "Toll Collect" in Germany	<input type="checkbox"/> MATL-SF	Lower flexizone mattress - semi-firm, pocket springs up to 100kg - 16 stone
<input type="checkbox"/> LOADIND	Load indicator with central dashboard display	<input type="checkbox"/> MATL-SO	Lower flexizone mattress - soft, pocket springs up to 85kg - 13.5 stone
<input type="checkbox"/> REMC-MF	Multi-functio wireless remote control	<input type="checkbox"/> OLMAT-BA	35mm mattress overlay protector
<input type="checkbox"/> FIREXT3S	3kg fire extinguisher mounted on seat base	<input type="checkbox"/> OLMAT-PR	50mm premium mattress overlay protector
<input type="checkbox"/> WARNVEST	High visibility warning vest - no sleeves	<input type="checkbox"/> TBK60F	Fixed foldable top bunk 600 x 1900mm
<input type="checkbox"/> AIDKIT	First aid kit	<input type="checkbox"/> TBK70F	Fixed foldable top bunk 700 x 1900mm
<input type="checkbox"/> AIDKIT1B	First aid kit	<input type="checkbox"/> PH-CAB2	1.8kW Air to air night heater
<input type="checkbox"/> WARNLAMP	Portable warning lamp	<input type="checkbox"/> PH-ENGCA	Engine and cab night heater
		<input type="checkbox"/> PH-SS	Short stop heater
		<input type="checkbox"/> SLCP-BAS	Basic sleeper control panel - includes interior light, parking heater, roof hatch and door lock

Standard Equipment

Optional Equipment

For more detailed information about cab and powertrain equipment, please refer to separate specification sheets.

For all possible options and combinations of options please consult your Volvo sales contact who can create a specification to match your requirements using the Volvo Sales Support system (VSS).

The factory reserves the right to modify design and change equipment without previous notification. The specification can vary from country to country.

MODEL RANGE

FM 13 6x2 Platform - Steered Pusher - Rear Air Suspension FM 62 PR3HA

- SAFE** Safe box for driver's personal items
 - ETSB-F** Storage on engine tunnel - on front top
 - ETSB-FR** Storage on engine tunnel - on front top and at rear cab wall
 - ETSB-FRS** Storage on engine tunnel - on front top & at rear cab wall & storage recessed into tunnel on right hand side
 - ETSB-FS** Storage on engine tunnel - on front top and storage recessed into tunnel on right hand side
 - ETSB-R** Storage on engine tunnel - box at rear cab wall
 - ETSB-RS** Storage on engine tunnel - at rear cab wall and storage recessed into tunnel on right hand side
 - ETSB-S** Storage on engine tunnel - recessed into tunnel on right hand side
 - RUS-BAS** Rear cab upper storage 154 litres - 300 mm high
 - RUS-HIG** Rear cab upper storage 245 litres - 440 mm high
 - TABLE** Folding and height adjustable table - on lower bunk
 - REF-ICPK** Fridge: engine tunnel mounted preparation kit
 - REFR-RUS** Fridge: 28 litre rear upper wall mounted with dividers
 - MICRO-PK** Preparation kit for microwave oven (wiring)
 - BOTH-D** One bottle holder under dashboard centre section
 - COFMA-PK** Coffee maker, preparation kit.
 - INLI-BAS** Interior white LED lights - basic
 - INLI-NL** Interior white and red night LED light with no dimmer
 - INLI-NLD** Interior white and red night LED light with dimmer
 - ARL-FLEX** Two flexible reading lamps (snake lamps)
 - RH-ECS** Glass roof & escape hatch - Electrically operated
 - RH-EE** Without roof hatch -Tinted glass emergency exit ONLY
 - RH-ETR** Glass roof & escape hatch - Electrically operated, tinted glass with rear opening
 - RH-MSR** Steel roof & escape hatch - Manually operated with rear opening
 - RH-MTR** Glass roof & escape hatch - Manually operated, tinted glass with rear opening
 - URH** Without roof hatch
 - SWIND-BS** Extra side window on both sides behind "B" pillar
 - SWIND-PS** Rear side window, passenger side
 - VANMIR** Vanity mirror in front shelf
 - AS-FUS** Extra shelf in front upper storage compartments
 - INFOT-PK** Preparation kit for the mounting of a flat screen TV in cab above the driver's door, includes bracket, electrical and speaker connections
- CAB EXTERIOR**
- PAICS-B** Basic cab paint - mirrors, sunvisor, instep and bumper supplied in natural finish - grey
 - PAICS-C** Complete cab - mirrors, insteps, sunvisor, and bumper finished in cab colour
 - GLAS-TIN** Tinted windows.
 - AWIND-RF** Rear window
 - DGLAS-L** Laminated door glass
 - LOCK-MAN** Manual door locking
 - LOCK-MRP** Manual door locking with internal remote control (from driver side) of passenger door
 - LOCK-REM** Central locking with remote control
 - BUMP-B** Plastic front bumper
 - BUMP-B2** Steel front bumper
 - BUMP-SP** Front bumper spoiler
 - GUARD-EH** Engine guard to protect sump and engine hoses
 - BUGNET** Insect screen in front of radiator
 - CTILT-P-E** Electrically operated hydraulic cab tilt
 - CTILT-P-M** Manually operated hydraulic cab tilt
 - FCABS-A** Front cab suspension - Air
 - FCABS-M** Front cab suspension - Mechanical spring
 - RCABS-A** Rear cab suspension - Air
 - RCABS-M** Rear cab suspension - Mechanical spring
 - MIRCOMF2** Electrically heated and operated FMX style main and wide-angle mirror on both sides, with manual passenger kerb mirror. To increase direct vision to the side the main mirrors have no cowlings
 - MIRCOMFM** Electrically heated and operated main with manual wide-angle mirror - both sides - and passenger kerb mirror
 - MIRSTD2** Electrically heated - FMX - main with wide angle mirror on both sides and kerb view mirror on passenger side, to increase direct vision to the side the main mirrors have no cowlings
 - MIRSTDFM** Electrically heated main mirror with wide angle mirror on both sides and kerb view mirror on passenger side
 - AMIR-F20** Auxiliary front view mirror with a 200mm radius
 - SUNV-H** External smoke grey sunvisor
 - AD-ROOF** Roof air deflector
 - AD-SIDEL** Side air deflector extension panels
 - AD-SIDES** Short cab side air deflector for rigid bodywork
 - HL-BASIC** Halogen H7 head lamps
 - HL-BHID** High intensity Bi-Xenon head lamps
 - HL-DBL** Bi-Xenon high intensity discharge and dynamic head lamps. Dipped beam follows the road, activated by a signal from the steering system.
 - HL-CLEAN** Head lamp cleaner - washer jets
 - HLP-ST** Headlamp protection
 - HL-ADJ** Headlight adjustment - Switch in cab
 - DRIVL2** Two spot lamps
 - UDRIVL** Without auxiliary driving lights
 - FOGL-WC** Front fog lights
 - CL-STAT** Static corner lights
 - ASL-RF2** Two Hella H11 70W spotlamps in sign box - only available with the basic headlight and no lower driving lights.
 - ASL-RFPK** Preparation kit for two spotlamps in sign box
 - BEACOA2F** Two front roof mounted amber beacon rotating warning lamps
 - BEACOA2R** Two rear roof mounted (on accessory bracket) amber beacon flashing warning LED lamps
 - BEACON-P** Roof beacon wire preparation
 - BEACONA4** Four roof mounted (2 front/2 rear) amber beacon rotating warning lamps
 - CABPT-R1** Single outlet for roof mounted accessories
 - CABPT-R2** Twin outlets for roof mounted accessories.
 - SPOTP-F** Spotlamp preparation in front, max 280W
 - SPOTP-R** Spotlamp preparation on roof, max 280W
 - SPOTP-RF** Spotlamp preparation on cab roof and in cab front, max 2x280W
 - ROS-IL2** Preparation kit for illuminated roof sign with switch loose in cab, fit after registration
 - CSGN-GTR** "Globetrotter" headboard logo
 - HORN-F1S** Single tone Jericho air horn chassis mounted
 - HORN-R2S** Two roof mounted air horns
 - ANT-CBR** Roof mounted antenna for CB radio, single aerial
 - ACCB-R-AP** Front, middle & rear roof mounted accessory brackets
 - ACCB-R-F** Front roof mounted accessory bracket
 - ACCB-R-FM** Front & middle roof mounted accessory brackets
 - ACCB-R-FR** Front & rear roof mounted accessory brackets
 - ACCB-R-M** Middle roof mounted accessory bracket
 - ACCB-R-R** Rear roof mounted accessory bracket
 - ACCB-R-RM** Rear & middle roof mounted accessory brackets
 - REFS-TW** White cab conspicuity markings by packed in cab
 - REFS-TY** Yellow cab conspicuity markings by packed in cab

Standard Equipment Optional Equipment

For more detailed information about cab and powertrain equipment, please refer to separate specification sheets.

For all possible options and combinations of options please consult your Volvo sales contact who can create a specification to match your requirements using the Volvo Sales Support system (VSS).

The factory reserves the right to modify design and change equipment without previous notification. The specification can vary from country to country.

MODEL RANGE

FM 13 6x2 Platform - Steered Pusher - Rear Air Suspension FM 62 PR3HA

SUPERSTRUCTURE PREPARATIONS

- **SRWL-PK** Wiring preparation for side & rear work/reverse lamps on side of chassis and a three-position switch, maximum 280W
- **SWL-2FW** Two H3 70W white front chassis mounted (LH/RH side) working lamps and a 2-position switch (On/Off)
- **SWL-2RW** Two H3 70W white rear chassis mounted (LH/RH side) working lamps and a 2-position switch (On/Off)
- **SWL-4W** 4 H3 70W white front (2) & rear (2) chassis mtd (LH/RH side) working lamps & 2-pos switch (On/Off)
- **SWL-PK** Wiring preparation for side work/reverse lamps on side of chassis and a three-position switch, maximum 280W

- **WLC-H2A** Two H3/70W working lamps with amber coloured lens high mounted back of cab
- **WLC-H2W** Two H3/70W white working lamps high mounted on the back of cab
- **WLC-PKCH** Preparation kit (cables and switch) for cab mounted chassis working lamp
- **WLC-PKH** Preparation kit, cables and switch for high mounted working lamps back of cab
- **WLC-PKL** Preparation kit, cables and switch for low mounted working lamps back of cab
- **WLC-PKLH** Preparation kit - cables and switch for low and high mounted working lamps back of cab.

- **ECBB-BAS** Body builder electrical centre without body builder module
- **ECBB-HIG** Body builder electrical centre with body builder module

- **BBCHAS1** One 7-pole connector for Body builder interface
- **BBCHAS3** Three 7-pole connectors for Body builder interface

- **BEPR-T2** Body builder electrical software preparation for tipper with remote control

- **EXSTER** External steering control, with VDS and bodybuilder module

- **TD-BAS** Trailer detection WITHOUT LED sensing
- **TD-LED** Trailer detection with LED sensing

- **FBA-BTF** Lower front body attachments for torsionally flexible - platform body
- **FBA-BTSF** Lower front body attachments for torsionally semi-flexible body - box or curtainsider

- **HBA-FSFB** Holes for body attachments - flexible/semi-flexible body
- **HBA-SB** Holes for body attachments - stiff body

- **RBA-T2** Lower rear body attachments for helper frame

- **CRANEPK1** Crane plates mounted to frame, for cranes up to 10 tonne metre capacity
- **CRANEPK2** Crane plates mounted to frame, for cranes up to 20 tonne metre capacity
- **CRANEPK4** Crane plates mounted to frame, for cranes up to 40 tonne metre capacity

- **AUXL-SPK** Electrical preparation kit - wiring and switch for snow plough lights

- **TAILPRE2** Tail lift preparation kit, wireless remote operation
- **TAILPREP** Taillift preparation kit - cab switch and warning in driver display

- **AESW2** Two Body builder bistable electrical switches (marked AUX1 / AUX2)
- **AESW2PK** 2 Body builder bistable el.switches (marked AUX1/AUX2) and prep. for 4 more switches

- **AUXSW-4** Wiring for 4 extra switches (from Body builder electrical centre to switch positions)

DELIVERY SERVICES

- **TGW-4GWL** GSM/GPRS/4G modem, LTE & WLAN for telematics gateway
- **FMS-PK** Fleet Management System gateway

VOLVO

Volvo Truck Corporation
volvotrucks.com