

MODEL RANGE

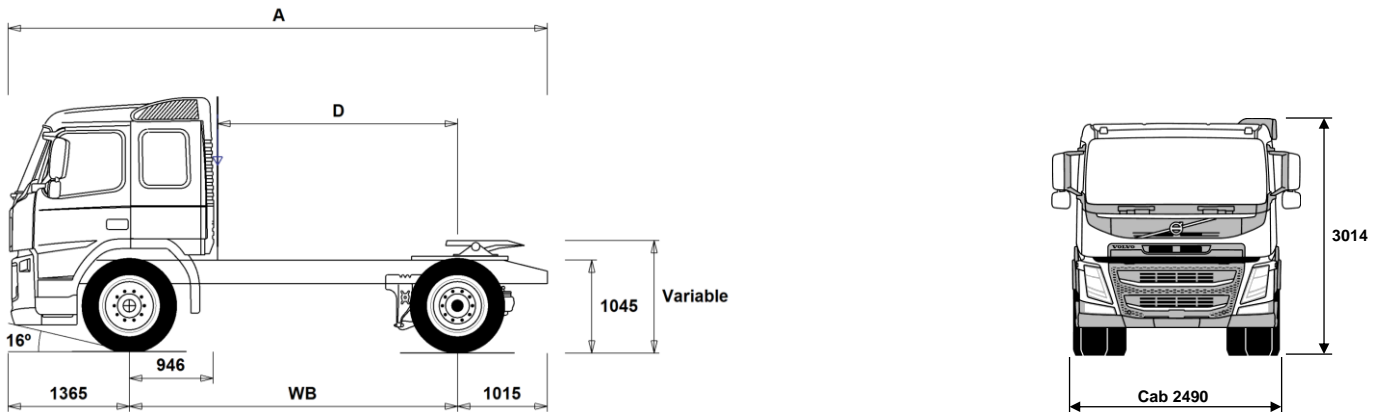

Volvo Trucks. Driving Progress

FM LNG 4x2 Tractor - Rear Air Suspension - Contact Regional Business Manager before



Chassis Dimensions [mm]

WB Wheelbase	3700	3800
A Overall Chassis Length	6080	6180
D Center of rear axle to back of cab	2704	2804
F Fifth Wheel Position (EC Directive 96/53)	575	575

Chassis Weights [kg]

Front Axle	4700	4710
Rear Axle	2415	2410
Kerb Weight	7115	7120

Turning Diameter [mm]

Turning Circle Diameter Kerb to Kerb	13400	13700
Turning Circle Diameter Wall to Wall	14800	15100

Plated Weights [kg]

	Plated	Design
Gross Vehicle Weight	18000	20100
Gross Combination Weight	40000	44000
Front Axle	7100	7100
Rear Axle	11500	13000

Important Notes

Chassis Dimensions

Cab Height: +416 mm for CAB-HSLP, -169 mm for CAB-LSLP, +554 mm for CAB-XHSL.

Front Axle to Back of Cab: -6 mm for CAB-LSLP.

D-measure includes a front clearance of 50 mm and for rigid trucks also a subframe of 100 mm.

Height can vary ± 20 mm for leaf and ± 10 mm for air suspension.

All dimensions are for unladen chassis and any tag axles down. Chassis height used: CHH-HIGH.

Height change when chassis height CHH-MED,FRAME266: 0 mm.

Weight and dimensions are based upon the following tyres:

Front Axle Tyres: 315/80R22.5
Drive Axle Tyres: 315/80R22.5

Chassis weight includes oil, water, AdBlue, 0 litres fuel and without driver. Kerb weight can vary $\pm 3\%$.

Turning diameters are theoretically calculated.

Legal weights can differ from country to country.

For more detailed weight information, including optional equipment weights, ask your Volvo sales contact to enter your specification into the Volvo Weight Information system (WIS).

Do NOT use this drawing for bodybuilding. Refer to Volvo Bodybuilder Instructions and chassis assembly drawing FM42TLA.

MODEL RANGE

FM LNG 4x2 Tractor - Rear Air Suspension - Contact Regional Business Manager before

CORE COMPONENTS

- CHH-HIGH** Chassis height high - N3 "On Road" chassis - For a specific loading height always check the unique BEP chassis drawing
- CHH-MED** Chassis height medium - For a specific loading height always check the unique BEP chassis drawing
- RAD-G4** RAD-G4 - 4x2 Air - Lite
- RAD-GR** RAD-GR- 4x2 Air - High
- FM-HSLP** Globetrotter cab - with steel safety cage design
Designed and built to Swedish impact and ECE R29 regulations
- FM-LSLP** Low sleeper cab - with steel safety cage design
Designed and built to Swedish impact and ECE R29 regulations
- FM-SLP** Sleeper cab - with steel safety cage design
Designed and built to Swedish impact and ECE R29 regulations
- G13C420** G13C420 Liquid Natural Gas engine developing 420hp at 1400-1800rpm. Peak torque 2100Nm at 1000 -1400rpm.
- G13C460** G13C460 Liquid Natural Gas engine developing 460hp at 1700-1800rpm. Peak torque 2300Nm at 1100 -1300rpm.
- EBR-EPGC** Exhaust pressure governor for I shift gearbox
- EBR-VEB+** Volvo engine brake + and exhaust pressure governor, enhanced performance from additional exhaust rocker control. Retardation 375kW
- AT2412F** AT2412F 12-speed "I-shift" automated mechanical gearbox suitable for gross train weights up to 44tonne only refer to sales engineering when used in conjunction with a PTO
- AT2612F** AT2612F 12-speed "I-shift" automated mechanical gearbox suitable for gross train weights up to 60tonne only refer to sales engineering when used in conjunction with a PTO
- ATO2612F** ATO2612F 12-speed "I-shift" overdrive automated mechanical gearbox suitable for gross train weights up to 60tonne refer to sales engineering when used in conjunction with a PTO
- RSH1370F** RSH1370F hub reduction rear axle with differential lock - design GCW 70 tonne
- RSS1344E** RSS1344E single reduction rear axle with differential lock - design GCW 44tonne
- RSS1352A** RSS1352A single reduction 13 tonne rear axle with differential lock - design GCW 52 tonne
- RSS1356** RSS1356 single reduction rear axle with differential lock - design GCW 56 tonne
- RSS1370A** RSS1370A single reduction 13 tonne rear axle with differential lock - design GCW 70 tonne
- RSS1370B** RSS1370B single reduction 13 tonne rear axle with differential lock - design GCW 70 tonne

PACKAGES

- DRIVE5** Cab Package: Drive
- DRIVE5+** Cab Package: Drive +
- DRIVE5++** Cab Package: Drive ++
- DRIVEFM** Cab Package: Drive
- DRIVEFM+** Cab Package: Drive +
- 1LIVINFM** Sleeper Package: Living package with single bunk
- 2LIVINFM** Sleeper Package: Living package with twin bunks
- BEDFM** One bed resting package
- AUDHIG** High Power Audio system: RDS radio with CD player - also playing MP3/WMA files from CD -, with integrated bluetooth phone and USB/Line inputs. FM/AM antenna, speakers in dashboard, doors, and sleeping compartment.
- MEDIA** AM/FM Bluetooth radio without CD player.
USB and Aux line inputs.
Speakers in dashboard, doors, and sleeping compartment.
7" touch screen with personal apps.
- MEDIADF** AM/FM Bluetooth radio without CD player.
USB and Aux line inputs.
Speakers in dashboard, doors, and sleeping compartment.
7" touch screen with personal and professional apps.

Standard Equipment

Optional Equipment

For more detailed information about cab and powertrain equipment, please refer to separate specification sheets.

For all possible options and combinations of options please consult your Volvo sales contact who can create a specification to match your requirements using the Volvo Sales Support system (VSS).

The factory reserves the right to modify design and change equipment without previous notification. The specification can vary from country to country.

- MEDIANAV** Dynafleet vehicle on-board data display with office internet support.
AM/FM Bluetooth radio without CD player.
USB and Aux line inputs.
Speakers in dashboard, doors, and sleeping compartment.
7" touch screen with personal and professional apps.
Truck based satellite navigation (live updates not included)
- MEDIANDF** AM/FM Bluetooth radio without CD player.
USB and Aux line inputs.
Speakers in dashboard, doors, and sleeping compartment.
7" touch screen with personal and professional apps.
Truck based satellite navigation (live updates not included)
Dynafleet vehicle on-board data display with office internet support.
- VISI15** Visibility Package
- VISI15+** Visibility Plus Package
- VISI5** Visibility Package
- VISI5+** Visibility + Package
- ASAF15** Active Safety Package
- SAFE-VE** Active Safety Package
- SAFE-VE+** Active Safety + Package

CHASSIS

- FST-AIR** Front suspension type - air
- FST-PAR** Front suspension type - 2 leaf parabolic springs
- FSL5-BAS** Front suspension levelling - basic stroke
- FSL5-HI** Front suspension levelling - high stroke for demount operations - check with bodybuilder
- FAL7.1** Front axle design capacity 7.1 tonnes
- FAL7.5** Front axle design capacity 7.5 tonnes
- FAL8.0** Front axle design capacity 8.0 tonnes - Ensure that you have checked the tyre load index
- FAL8.5** Front axle design capacity 8.5 tonnes
- FAL9.0** Front axle design capacity 9.0 tonnes - Ensure that you have checked the tyre load index
- FSTAB** Front anti-roll bar
- FSTAB2** Front anti-roll bar medium stiffness
- FSTAB3** Front stiff anti-roll bar
- RAL11.7** Rear bogie design capacity 11.7 tonnes
- RAL13** Rear axle design capacity 13 tonnes
- RSTAB1** Rear anti-roll bar
- RSTAB3** Rear stiff anti-roll bar
- ASF-DL1** Air suspension with 1 driving level
- ASF-DL3** Air suspension with 3 driving levels
- ACTST-TO** Volvo Dynamic Steering (VDS) with with extra electronic pump and torque overlay
- ASFE-BAS** Active steering feature - Basic - Volvo Dynamic Steering only
- ASFE-OG** Active steering feature - Volvo Dynamic Steering with stability assist - oversteer
- ASFE-PO** Active steering feature - Volvo Dynamic Steering with personal settings and stability assist
- ASFE-PS** Active steering feature - Volvo Dynamic Steering with personal settings
- PSS-SING** Single power steering system
- PSP-VAR** Power steering pump with variable displacement
- EBS-MED** EBS medium package including "hill" hold function
- AUXPARK** Additional spring parking brakes
- FBREG-E** Front regulating brake valve, EBS
- SUSPL-EC** Remote electronic control on wander-lead for air suspension levelling
- FRAME266** Frame rail section external height 266 mm
- FRAME300** Frame rail section external height 300 mm
- FST6060** Frame thickness - web and flange 6.0mm
- FST6565** Frame thickness - web and flange 6.5mm
- FST7070** Frame thickness - web and flange 7.0mm

MODEL RANGE

FM LNG 4x2 Tractor - Rear Air Suspension - Contact Regional Business Manager before

<input type="checkbox"/> FST8080	Frame thickness - web and flange 8.0mm	<input checked="" type="checkbox"/> TL-LED	Rear lights LED
<input type="checkbox"/> FIL-EEEB	Inner liner from end of engine to end of bogie	<input type="checkbox"/> BLIGHT-E	Emergency brake light
<input type="checkbox"/> FIL-TXEB	Inner liner from gearbox member to end of bogie	WHEELS & TYRES	
<input checked="" type="checkbox"/> BBOX-EF	Battery box located in the end of frame	<input type="checkbox"/> RT-AL	Alcoa brushed aluminium rims with standard holes for long stud fixing on all axles
<input checked="" type="checkbox"/> 2BAT210B	2 x 210 Ah capacity Gel batteries	<input type="checkbox"/> RT-ALDP	Alcoa Dura-Bright EVO aluminium rims with standard holes long stud fixing on all axles, requires cleaning with a ph neutral solution - washing up liquid.
<input checked="" type="checkbox"/> 2BATT225	2 x 225 Ah capacity batteries	<input type="checkbox"/> RT-ALDPD	Alcoa Dura-Bright EVO aluminium rims with countersunk holes for short stud fixing on all axles, requires cleaning with a ph neutral solution - washing up liquid.
<input checked="" type="checkbox"/> BATTAMP	Battery voltage and ampere gauge	<input type="checkbox"/> RT-ALDU	Alcoa brushed aluminium rims with countersunk holes for short stud fixing on all axles
<input type="checkbox"/> BATTIND	Battery charge indication	<input checked="" type="checkbox"/> RT-STEEL	Steel rims on all axles
<input type="checkbox"/> ADR1	ADR package for transportation of dangerous goods on road (Note does NOT include safe loading pass package if required this is quoted separately)	<input type="checkbox"/> WCAP	Aerodynamic hub caps
<input type="checkbox"/> ADR2	ADR package for transportation of dangerous goods on road (Note does NOT include safe loading pass package if required this is quoted separately)	<input type="checkbox"/> BRREC001	Bridgestone ECOPIA H - Energy rating C
<input type="checkbox"/> MSWI-A	Main switch - ADR switch circuit shut down	<input checked="" type="checkbox"/> BRREC002	Bridgestone Ecopia H 002 Evo - Tyre recommendation 2
<input checked="" type="checkbox"/> MSWI-C	Main switch - Chassis mounted toggle switch by battery box	<input type="checkbox"/> COREC001	Continental ECOPLUS HS3 XL/HD3 - Energy rating B or C depending on size
<input type="checkbox"/> MSWI-R	Main switch - Key fob operated remote controlled	<input type="checkbox"/> COREC002	Continental ECOPLUS HS3/HD3 - Energy rating B or C depending on size
<input checked="" type="checkbox"/> R170A71	Right aluminium 710mm 170litre (165l usable) D-shaped fuel tank Min volume 170l Max volume 170l	<input type="checkbox"/> COREC003	Continental Efficient Pro S/D - Fuel Tyre Recommendation 3 Reduced mileage compared to Conti EcoPlus long haul pattern please consider when selecting these tyres.
<input type="checkbox"/> ADTP-BC	AdBlue tank behind/under cab on right hand side	<input type="checkbox"/> GYREC001	Goodyear FUELMAX S/HL/D - Energy rating B or C depending on size
<input checked="" type="checkbox"/> ADTP-R	AdBlue tank on right hand side	<input type="checkbox"/> GYREC002	Goodyear FUELMAX S/D - Energy rating B or C depending on size
<input type="checkbox"/> ADB050	AdBlue tank usable volume 50 litres - under cab	<input type="checkbox"/> GYREC004	Goodyear FUELMAX S - Energy rating B depending on size
<input checked="" type="checkbox"/> ADB064	AdBlue tank usable volume 64 litres	<input type="checkbox"/> HAREC001	Hankook AL10+ E-Cube Max Long Haul Tyre - Energy rating B
<input checked="" type="checkbox"/> FCAP-L	Locking fuel filler cap	<input type="checkbox"/> HAREC002	Hankook AL10+ E-Cube Long Haul Tyre - Energy rating B with wide single
<input checked="" type="checkbox"/> FUFF-AS	Fuel filling anti-spillage device	<input type="checkbox"/> MIREC001	Michelin XFA2/X-LINE Energy - Fuel tyre Recommendation 1
<input checked="" type="checkbox"/> FUFF-ATS	Fuel filling anti-theft and anti-spillage devices	<input type="checkbox"/> MIREC002	Michelin XZA2/X-LINE Energy - Fuel tyre Recommendation 2
<input checked="" type="checkbox"/> LGAS205	Left mounted 205 kilogram gas tank	<input type="checkbox"/> MIREC003	Michelin X-LINE Energy - Fuel tyre Recommendation 3
<input checked="" type="checkbox"/> ESH-REAR	Horizontal silencer, rear exhaust outlet	<input type="checkbox"/> MIREC004	Michelin X Line Energy F/D2 - Energy rating A
<input type="checkbox"/> ESH-RIGH	Horizontal silencer, right exhaust outlet	<input type="checkbox"/> PIREC001	Pirelli FH:01 Proway - Long Haul Tyre - Energy rating B
<input type="checkbox"/> WHC-FOL1	One foldable wheel chock	<input type="checkbox"/> PIREC002	Pirelli FH:01 II Long Haul Tyre - Energy rating B with wide single
<input type="checkbox"/> WHC-FOL2	Two foldable wheel chocks	<input type="checkbox"/> SPWT-D	Spare wheel & tyre with rear tyre pattern
<input type="checkbox"/> WHCP-T	Transport mounted wheel chock(s) stored in cab outer luggage locker	<input type="checkbox"/> SPWT-F	Spare wheel & tyre with front tyre pattern
<input type="checkbox"/> TB-R80	Toolbox 800 mm, right side	<input type="checkbox"/> SWCP-T	Spare wheel supplied temporarily strapped to chassis
<input type="checkbox"/> CHAIN-S	Snow chains	<input type="checkbox"/> SWCP-TP	Temporary spare wheel carrier on top of chassis frame
<input type="checkbox"/> HOOK-SC	Snow chain hooks	<input type="checkbox"/> JACK-12T	12 tonne bottle jack
<input checked="" type="checkbox"/> TOWF-NO1	One front towing device	<input type="checkbox"/> JACK-15T	15 tonne bottle jack
<input type="checkbox"/> TOWF-NO2	Two front towing devices	<input type="checkbox"/> JACK-20T	20 tonne bottle jack
<input checked="" type="checkbox"/> RFEC-B	Rear frame end, bent down - standard for tractor vehicles	<input checked="" type="checkbox"/> TOOL-BAS	Basic Toolkit
<input type="checkbox"/> TOWR-ONE	Towing hitch attached to rear crossmember	<input type="checkbox"/> TOOLKIT	Complete tool kit
<input type="checkbox"/> TREL15	Single 15 pole electrical trailer connector - ADR certified	<input type="checkbox"/> INFLAHOS	Tyre inflation hose
<input type="checkbox"/> TREL7	7 pole - 24N trailer electrical suzie	<input type="checkbox"/> GAUGE-TP	Tyre pressure gauge
<input checked="" type="checkbox"/> TREL7-7	24N and 24S trailer electrical suzies	DRIVELINE EQUIPMENT	
<input type="checkbox"/> TBC-DUO	Duomatic type air line connectors	<input type="checkbox"/> TRAP-HD	Reinforced gearbox application
<input type="checkbox"/> TBC-EC	Palm coupling type air line connectors	<input type="checkbox"/> TP-CON	Construction Package
<input checked="" type="checkbox"/> TBC-GBR	'C' and 'CA' type air line connectors	<input type="checkbox"/> TP-DIST	Distribution Package
<input type="checkbox"/> TRBR-HCF	Full pressure hand controlled trailer brake	<input type="checkbox"/> TP-LONG	Long Haul Package
<input checked="" type="checkbox"/> TRBR-STA	Stationary trailer brake control	<input type="checkbox"/> AMSO-AUT	Enhanced I-shift software with manual shift available in auto mode and kickdown facility on accelerator pedal
<input type="checkbox"/> TRB-STRE	Stretch Brake - Automatic low speed trailer brake activation to avoid jack-knifing and improve steerability	<input type="checkbox"/> AVO-ENH	Enhanced software for off road driveability and starting
<input checked="" type="checkbox"/> RFEND-B	Three piece EC approved rear mud wings and spray flaps	<input type="checkbox"/> APF-ENH	I-shift enhanced PTO functions
<input checked="" type="checkbox"/> RFH-BAS	Basic rear wing height	<input type="checkbox"/> RET-TH	Gearbox mounted retarder
<input type="checkbox"/> RFH-HIG	High rear wing height - higher wing tops	<input type="checkbox"/> TC-MAO	Basic transmission oil cooler - air to oil
<input type="checkbox"/> RFH-LOW	Lower rear wing height - shallower wing tops	<input type="checkbox"/> TC-MAOH2	Extra high performance transmission oil cooler - air to oil with front mounted radiator
<input type="checkbox"/> ATANK-AL	Aluminium air tanks	<input type="checkbox"/> 2COM1100	Two cylinder, air compressor, 1100 litres per minute
<input checked="" type="checkbox"/> ATANK-ST	Steel air tanks		
<input checked="" type="checkbox"/> Standard Equipment		<input type="checkbox"/> Optional Equipment	

For more detailed information about cab and powertrain equipment, please refer to separate specification sheets.

For all possible options and combinations of options please consult your Volvo sales contact who can create a specification to match your requirements using the Volvo Sales Support system (VSS).

The factory reserves the right to modify design and change equipment without previous notification. The specification can vary from country to country.

MODEL RANGE

FM LNG 4x2 Tractor - Rear Air Suspension - Contact Regional Business Manager before

■ 2COMP900	Two cylinder, air compressor, 900 litres per minute		
□ CLU-AIRC	Clutchable air compressor		
■ AIRIN-HI	Roof mounted air intake behind cab on left hand side		
□ AIRIN-LO	Low level air intake behind cab on left hand side		
□ ACL1ST-S	Two stage air filter		
■ 24AL110B	110 amp alternator		
□ 24AL120B	120 amp alternator		
□ 24AL150B	150 amp alternator		
■ CCV-OX	Closed crankcase ventilation for cold markets		
□ PRIM-MAN	Manual priming pump		
□ FUEFE2LW	Large engine mounted dual fuel filter with water separator		
■ FUEFE2SW	Small engine mounted dual fuel filter with water separator		
■ EST-AID	Air inlet manifold starting heater element		
□ 220EBH15	220V/1.5Kw electric engine block heater		
□ PTER-DIN	Rear engine mounted PTO with DIN5462 (female) splined shaft for a close coupled pump. Models with 3 steering axles will use this to drive the steering pump (AUXPSP)		
□ PTR-D	Gearbox PTO for plug-in pump, 0.71xeng speed		
□ PTR-DH	Gearbox driven high speed PTO for one plug-in hydraulic pump		
□ PTR-DM	Gearbox driven medium speed PTO for one plug-in hydraulic pump		
□ PTR-F	Gearbox driven PTO with rear flange connection		
□ PTR-FH	Gearbox driven high speed PTO with SAE drive flange		
□ PTR-FL	Gearbox driven low speed PTO with SAE drive flange		
□ PTRD-D	Gearbox driven HIGH SPEED PTO for two plug-in hydraulic pumps		
□ PTRD-D1	PTRD-D1 Gearbox driven HIGH SPEED PTO (1 SAE flange & 1 plug-in hydraulic pump)		
□ PTRD-D2	Gearbox driven HIGH SPEED PTO (2 SAE flanges & 1 plug-in hyd pump)		
□ PTRD-F	PTO with 1 DIN + 1 flange connection rear, manual gearbox		
□ HPG-F101	Parker F1-101 gearbox mounted, fixed displacement, single flow, hydraulic pump		
□ HPG-F41	Parker F1-41 gearbox mounted, fixed displacement, single flow, hydraulic pump		
□ HPG-F51	Parker F1-51 gearbox mounted, fixed displacement, single flow, hydraulic pump		
□ HPG-F61	Parker F1-61 gearbox mounted, fixed displacement, single flow, hydraulic pump		
□ HPG-F81	Parker F1-81 gearbox mounted, fixed displacement, single flow, hydraulic pump		
□ EIDLESD	Engine idle shut down		
□ DTRI-PER	Dashboard in darker peregrine greyish brown. Steering wheel grey and door panels in light beige for FH and black for FH16.		
■ STWPOS-R	RIGHT HAND DRIVE		
□ STWM-LE	Leather steering wheel		
□ STGW-AD2	Adjustable steering wheel with neck tilt		
■ STGW-ADJ	Adjustable steering wheel		
■ AIRBAG	SRS Driver's air bag		
■ DRC-AMII	DPF Regeneration control switch - for manual and switching off regeneration		
□ 1DAYDIG	Continental VDO DTCO 3.0 digital tachograph This tachograph can ONLY offer remote download if the option of Dynafleet or an FMS gateway has been specified with this order.		
□ 1DAYDIGP	Continental VDO DTCO 3.0 digital tachograph For vehicles with long lead time - this includes prep kit for the retrofit of DTCO 4.0 tachograph. For updating to new legal demand for trick registration from 15th June 2019. This tachograph can ONLY offer remote download if the option		
		of Dynafleet or an FMS gateway has been specified with this order.	
		□ ARSL	Additional road speed limit - switch in dashboard
		□ CRUIS-E	Eco cruise control (with eco-roll and I-cruise, controls in steering wheel)
		■ CRUISEC	Cruise control, standard
		■ ESP-BAS1	Electronic Stability Control
		□ ESPC-RO	ESP (Electronic Stability Program) functionality control - Reduced / Off
		□ HWSS-ACB	Adaptive cruise control ACC with forward collision warning and AEBS advanced emergency brake system
		■ HWSS-FCB	Forward collision warning with AEBS advanced emergency brake system
		■ LSS-DW	Lane departure-warning system
		□ LCS	Lane change support
		□ DAS-W	Driver Alert Support system
		□ RSENS-W	Rain sensing windscreen wipers
		□ CU-ECC	Electrically controlled air conditioning with sun sensor
		□ CU-ECC2	Electrically controlled air conditioning with sun sensor, mist sensor, air quality sensor and carbon filter
		■ CU-MCC	Climate unit with manual controlled air conditioning
		■ IMMOBIL	Thatcham H2 approved immobiliser
		□ ALARM-B	Thatcham H1 approved vehicle alarm - Cab only
		□ ALARM-E	Enhanced vehicle alarm - Thatcham H1 approved - Cab plus external sensor for body/trailer
		□ ALCOLOCK	Alcolock
		□ BUPMON	Back up monitor with built in 7" screen on dash and one colour camera supplied loose for fitment by bodybuilder. Can accommodate up to 4 cameras for TfL Safe Scheme, CLOCS and FORS.
		□ PHONE-PK	Telephone preparation kit (antenna, antenna attachm. cable incl.)
		□ WLIFT-AD	Electrical window lift, automatic up/down driver side
		■ WLIFT-EB	Electrical window lift
		□ WLIFT-ME	Mechanical window lift
		□ ISUNS-BS	Side interior sun visor on both sides
		■ ISUNS-DS	Driver's side interior sun visor
		■ ISUNF-B	Interior front sun visor without mirror
		□ ISUNF-MD	Interior front sun visor with mirror on driver side
		□ ISUNF-RE	Electrically operated textile interior sun blind
		□ ISUNF-RM	Manually operated textile interior sun blind
		□ ADFS	Two extra DIN slots in front shelf - can be fitted with card or drawer available as an accessory
		■ BUPALARM	Reverse alarm
		□ RTOLL-PK	Road toll PREPARATION kit for trucks operating with "Toll Collect" in Germany
		□ LOADIND	Load indicator with central dashboard display
		□ REMC-MF	Multi-functio wireless remote control
		□ FIREXT3S	3kg fire extinguisher mounted on seat base
		□ WARNVEST	High visibility warning vest - no sleeves
		□ AIDKIT	First aid kit
		□ AIDKIT1B	First aid kit
		□ WARNLAMP	Portable warning lamp
		□ LAMP-IN	Inspection lamp
		□ BULBKIT	Bulb and fuse kit
		□ WRITEPAD	Writing pad

■ Standard Equipment

□ Optional Equipment

For more detailed information about cab and powertrain equipment, please refer to separate specification sheets.

For all possible options and combinations of options please consult your Volvo sales contact who can create a specification to match your requirements using the Volvo Sales Support system (VSS).

The factory reserves the right to modify design and change equipment without previous notification. The specification can vary from country to country.

MODEL RANGE

FM LNG 4x2 Tractor - Rear Air Suspension - Contact Regional Business Manager before

- UPHTRI10** Seats: Black embossed textile insert with light grey sides, black vinyl side bolster with blue vinyl side insert.
Interior trim: Raven black bunk and curtains & blue textile side walls
 - UPHTRI11** Seats: Light grey embossed textile insert, black raven metallic vinyl bolster with red vinyl side insert.
Interior trim: Raven black bunk and curtains & grey vinyl side walls
 - UPHTRI12** Seats: Blue soft textile insert, black vinyl bolster.
Interior trim: Raven black bunk and curtains & blue textile side walls
 - UPHTRI13** Seats: Dark grey leather insert and black leather bolster.
Interior trim: Raven black bunk and curtains & grey vinyl side walls
 - UPHTRI14** Seat: Dark grey leather insert and black leather bolster.
Interior trim: Raven black bunk and curtains & blue textile side walls
 - DST-CF4** Driver seat, comfort, suspended, belt in seat
 - DST-CF5** Driver seat, comfort, suspended, belt in seat, electrically heated
 - DST-CF6** Driver seat, comfort, suspended, belt in seat, electrically heated, ventilated
 - SBD-RED** Red seat belts
 - SBPRE-DS** Driver seat belt pretensioner
 - PST-BAS1** Passenger seat - Fixed non suspended fold up with seatbelt mounted in cab
 - PST-BENC** Bench passenger seat
 - PST-CF4** Passenger seat - Comfort suspended with seatbelt mounted in seat
 - PST-CF5** Passenger seat - Comfort suspended & heated with seatbelt mounted in seat
 - PST-STD2** Passenger seat - Fixed non suspended with seatbelt mounted in cab
 - PST-STD4** Passenger seat - Standard suspended with seatbelt mounted in cab
 - SBPRE-PS** Passenger seat belt pretensioner
 - ARM-DBPS** Two armrests on driver seat and one (outer) on passenger seat
 - ARMRE-BB** Two armrests on both driver and passenger seat.
 - ARMRE-DB** Two armrests, on driver seat only
 - ARMRE-PB** Two armrests, on passenger seat only
 - ARMRE-PS** Single armrest (next to driver) on passenger seat
 - ARU-BAS** Vinyl upholstered armrest
 - ARU-LEA** Leather upholstered armrest
 - FMAT-RUB** Rubber floor mats
 - FMAT-TX2** Textile and rubber floor mats
 - LBK70** Lower bunk 700 x2000 mm, fixed
 - MATL-FI** Firm lower bunk pocket sprung mattress
 - MATL-SF** Lower flexizone mattress - semi-firm, pocket springs up to 100kg - 16 stone
 - MATL-SO** Lower flexizone mattress - soft, pocket springs up to 85kg - 13.5 stone
 - OLMAT-BA** 35mm mattress overlay protector
 - OLMAT-PR** 50mm premium mattress overlay protector
 - TBK60F** Fixed foldable top bunk 600 x 1900mm
 - TBK70F** Fixed foldable top bunk 700 x 1900mm
 - PH-CAB2** 1.8kW Air to air night heater
 - PH-ENGCA** Engine and cab night heater
 - PH-SS** Short stop heater
 - SLCP-BAS** Basic sleeper control panel - includes interior light, parking heater, roof hatch and door lock
 - SAFE** Safe box for driver's personal items
 - ETSB-F** Storage on engine tunnel - on front top
 - ETSB-FS** Storage on engine tunnel - on front top and storage recessed into tunnel on right hand side
 - ETSB-S** Storage on engine tunnel - recessed into tunnel on right hand side
 - RUS-BAS** Rear cab upper storage 154 litres - 300 mm high
 - RUS-HIG** Rear cab upper storage 245 litres - 440 mm high
 - TABLE** Folding and height adjustable table - on lower bunk
 - REF-ICPK** Fridge: engine tunnel mounted preparation kit
 - REFR-RUS** Fridge: 28 litre rear upper wall mounted with dividers
 - BOTH-D** One bottle holder under dashboard centre section
 - COFMA-PK** Coffee maker, preparation kit.
 - INLI-BAS** Interior white LED lights - basic
 - INLI-NL** Interior white and red night LED light with no dimmer
 - INLI-NLD** Interior white and red night LED light with dimmer
 - ARL-FLEX** Two flexible reading lamps (snake lamps)
 - RH-ECS** Glass roof & escape hatch - Electrically operated
 - RH-EE** Without roof hatch -Tinted glass emergency exit ONLY
 - RH-ETR** Glass roof & escape hatch - Electrically operated, tinted glass with rear opening
 - RH-MSR** Steel roof & escape hatch - Manually operated with rear opening
 - RH-MTR** Glass roof & escape hatch - Manually operated, tinted glass with rear opening
 - URH** Without roof hatch
 - SWIND-BS** Extra side window on both sides behind "B" pillar
 - SWIND-PS** Rear side window, passenger side
 - VANMIR** Vanity mirror in front shelf
 - AS-FUS** Extra shelf in front upper storage compartments
 - INFOT-PK** Preparation kit for the mounting of a flat screen TV in cab above the driver's door, includes bracket, electrical and speaker connections
- ### CAB EXTERIOR
- EXTL-BAS** Basic exterior finish - - Matt Volvo badges, grey instep, bumper, bumper spoiler, mirror housing and sun visor
 - PAICS-B** Basic cab paint - mirrors, sunvisor, instep and bumper supplied in natural finish - grey
 - PAICS-C** Complete cab - mirrors, insteps, sunvisor, and bumper finished in cab colour
 - GLAS-TIN** Tinted windows.
 - AWIND-RF** Rear window
 - DGLAS-H** Tempered door glass
 - DGLAS-L** Laminated door glass
 - LOCK-MAN** Manual door locking
 - LOCK-MRP** Manual door locking with internal remote control (from driver side) of passenger door
 - LOCK-REM** Central locking with remote control
 - BUMP-B** Plastic front bumper
 - BUMP-B2** Steel front bumper
 - BUMP-SP** Front bumper spoiler
 - GUARD-EH** Engine guard to protect sump and engine hoses
 - BUGNET** Insect screen in front of radiator
 - CTILTP-E** Electrically operated hydraulic cab tilt
 - CTILTP-M** Manually operated hydraulic cab tilt
 - FCABS-A** Front cab suspension - Air
 - FCABS-M** Front cab suspension - Mechanical spring
 - RCABS-A** Rear cab suspension - Air
 - RCABS-M** Rear cab suspension - Mechanical spring
 - MIRCFPCS** Electrically heated and operated main and wide angle mirrors with manually adjusted kerb view mirror on passenger side and position camera in offside mirror arm.
 - MIRCOMF** Electrically heated and operated main and wide angle mirrors and manually adjusted kerb view mirror on passenger side
 - MIRCOMF2** Electrically heated and operated FMX style main and wide-
- Standard Equipment □ Optional Equipment

For more detailed information about cab and powertrain equipment, please refer to separate specification sheets.

For all possible options and combinations of options please consult your Volvo sales contact who can create a specification to match your requirements using the Volvo Sales Support system (VSS).

The factory reserves the right to modify design and change equipment without previous notification. The specification can vary from country to country.

MODEL RANGE

FM LNG 4x2 Tractor - Rear Air Suspension - Contact Regional Business Manager before

	angle mirror on both sides, with manual passenger kerb mirror. To increase direct vision to the side the main mirrors have no cowlings	<input type="checkbox"/> 5WM-ISOL <input checked="" type="checkbox"/> 5WM-ISOM	5th wheel subframe 16mm high above chassis frame 5th wheel subframe 60mm high above chassis frame L profiles 50mm with 10mm thick plate
<input type="checkbox"/> MIRCOMFM	Electrically heated and operated main with manual wide-angle mirror - both sides - and passenger kerb mirror	<input type="checkbox"/> 5WM-LPRO <input type="checkbox"/> 5WM-MASL <input type="checkbox"/> 5WM-MASM	5th wheel attached direct to frame with inverted 'L'-profiles 4mm high 'L' profiles for manual sliding fifth wheel 50mm high 'L' profiles for manual sliding fifth wheel
<input type="checkbox"/> MIRSTD	Electrically heated main and wide angle mirrors and manually adjusted kerb view mirror on passenger side	<input type="checkbox"/> 5WH140 <input type="checkbox"/> 5WH150 <input type="checkbox"/> 5WH160 <input type="checkbox"/> 5WH175 <input type="checkbox"/> 5WH185 <input type="checkbox"/> 5WH195 <input type="checkbox"/> 5WH200 <input type="checkbox"/> 5WH205 <input type="checkbox"/> 5WH210 <input type="checkbox"/> 5WH220 <input type="checkbox"/> 5WH230	Fifth wheel leg-height 140 mm Fifth wheel leg-height 150 mm Fifth wheel leg-height 160 mm Fifth wheel leg height 175mm Fifth wheel leg-height 185 mm Fifth wheel leg-height 195mm Fifth wheel leg-height 200 mm Fifth wheel leg-height 205 mm Fifth wheel leg-height 210 mm Fifth wheel leg-height 220mm Fifth wheel leg-height 230 mm
<input type="checkbox"/> MIRSTD2	Electrically heated - FMX - main with wide angle mirror on both sides and kerb view mirror on passenger side, to increase direct vision to the side the main mirrors have no cowlings		
<input checked="" type="checkbox"/> MIRSTDFM	Electrically heated main mirror with wide angle mirror on both sides and kerb view mirror on passenger side		
<input checked="" type="checkbox"/> AMIR-F20	Auxiliary front view mirror with a 200mm radius		
<input type="checkbox"/> SUNV-H	External smoke grey sunvisor		
<input type="checkbox"/> AD-ROOF	Roof air deflector		
<input type="checkbox"/> AD-SIDEL	Side air deflector extension panels		
<input type="checkbox"/> AD-SIDES	Short cab side air deflector for rigid bodywork		
<input checked="" type="checkbox"/> HL-BASIC	Halogen H7 head lamps		
<input type="checkbox"/> HL-BHID	High intensity Bi-Xenon head lamps		
<input type="checkbox"/> HL-DBL	Bi-Xenon high intensity discharge and dynamic head lamps. Dipped beam follows the road, activated by a signal from the steering system.		
<input type="checkbox"/> HL-CLEAN	Head lamp cleaner - washer jets		
<input type="checkbox"/> HLP-ST	Headlamp protection		
<input type="checkbox"/> HL-ADJ	Headlight adjustment - Switch in cab		
<input type="checkbox"/> DRIVL2	Two spot lamps		
<input checked="" type="checkbox"/> UDRIVL	Without auxiliary driving lights		
<input checked="" type="checkbox"/> FOGL-WC	Front fog lights		
<input type="checkbox"/> CL-STAT	Static corner lights		
<input type="checkbox"/> ASL-RF2	Two Hella H11 70W spotlamps in sign box - only available with the basic headlight and no lower driving lights. Preparation kit for two spotlamps in sign box		
<input type="checkbox"/> ASL-RFPK	Preparation kit for two spotlamps in sign box		
<input type="checkbox"/> BEACOA2F	Two front roof mounted amber beacon rotating warning lamps		
<input type="checkbox"/> BEACOA2R	Two rear roof mounted (on accessory bracket) amber beacon flashing warning LED lamps		
<input type="checkbox"/> BEACON-P	Roof beacon wire preparation		
<input type="checkbox"/> BEACONA4	Four roof mounted (2 front/2 rear) amber beacon rotating warning lamps		
<input type="checkbox"/> CABPT-R1	Single outlet for roof mounted accessories		
<input checked="" type="checkbox"/> CABPT-R2	Twin outlets for roof mounted accessories.		
<input type="checkbox"/> SPOTP-F	Spotlamp preparation in front, max 280W		
<input type="checkbox"/> SPOTP-R	Spotlamp preparation on roof, max 280W		
<input type="checkbox"/> SPOTP-RF	Spotlamp preparation on cab roof and in cab front, max 2x280W		
<input type="checkbox"/> ROS-IL2	Preparation kit for illuminated roof sign with switch loose in cab, fit after registration		
<input type="checkbox"/> CSGN-GTR	"Globetrotter" headboard logo		
<input checked="" type="checkbox"/> HORN-F1S	Single tone Jericho air horn chassis mounted		
<input checked="" type="checkbox"/> HORN-R2S	Two roof mounted air horns		
<input type="checkbox"/> ANT-CBR	Roof mounted antenna for CB radio, single aerial		
<input type="checkbox"/> ACCBR-AP	Front, middle & rear roof mounted accessory brackets		
<input type="checkbox"/> ACCBR-F	Front roof mounted accessory bracket		
<input type="checkbox"/> ACCBR-FM	Front & middle roof mounted accessory brackets		
<input type="checkbox"/> ACCBR-FR	Front & rear roof mounted accessory brackets		
<input type="checkbox"/> ACCBR-M	Middle roof mounted accessory bracket		
<input type="checkbox"/> ACCBR-R	Rear roof mounted accessory bracket		
<input type="checkbox"/> ACCBR-RM	Rear & middle roof mounted accessory brackets		
<input type="checkbox"/> REFS-TW	White cab conspicuity markings by packed in cab		
<input type="checkbox"/> REFS-TY	Yellow cab conspicuity markings by packed in cab		
SUPERSTRUCTURE PREPARATIONS			
<input type="checkbox"/> 5WM-ASL	4mm high 'L' profiles for air actuated sliding 5th wheel		
<input type="checkbox"/> 5WM-ASM	50mm high 'L' profiles for air actuated sliding 5th wheel		
<input checked="" type="checkbox"/> 5WT-FO14	Fontaine 150SP2 pressed steel fifth wheel		
<input type="checkbox"/> 5WT-FO15	Fontaine 3000 lightweight cast fifth wheel with 150SF air operated slider - for moderate duty off road. Specified fifth wheel position always gives rearmost position.		
<input type="checkbox"/> 5WT-JO10	Jost JSK 36 pressed fifth wheel		
<input type="checkbox"/> 5WT-JO8	Jost JSK 37 cast fifth wheel		
<input type="checkbox"/> 5WT-JO9	Jost JSK 42 cast fixed fifth wheel		
<input type="checkbox"/> 5WT-SH	SAF-Holland/+GF+ SK-S 36.20 cast fixed fifth wheel		
<input checked="" type="checkbox"/> 5WLM-B	Basic fifth wheel maintenance standard top plate		
<input type="checkbox"/> 5WLM-L	Low maintenance fifthwheel with nylon top plate		
<input type="checkbox"/> 5WL-S1	Fifth wheel lubrication - locking mechanism and top plate		
<input type="checkbox"/> 5WL-S2	Fifth wheel lubrication - locking mechanism		
<input type="checkbox"/> TCIND	Trailer connection indication with sensors for height, kingpin and coupling lock		
<input checked="" type="checkbox"/> RDECK	Catwalk & step		
<input type="checkbox"/> RDECK-M	Rear catwalk 760mm		
<input type="checkbox"/> SRWL-PK	Wiring preparation for side & rear work/reverse lamps on side of chassis and a three-position switch, maximum 280W		
<input type="checkbox"/> SWL-2RA	Two H3 35W amber rear chassis mounted (LH/RH side) working lamps and a 2-position switch (On/Off)		
<input type="checkbox"/> SWL-2RW	Two H3 70W white rear chassis mounted (LH/RH side) working lamps and a 2-position switch (On/Off)		
<input type="checkbox"/> SWL-PK	Wiring preparation for side work/reverse lamps on side of chassis and a three-position switch, maximum 280W		
<input checked="" type="checkbox"/> WL-TA1W	White coupling light		
<input type="checkbox"/> WLC-H2A	Two H3/70W working lamps with amber coloured lens high mounted back of cab		
<input type="checkbox"/> WLC-H2W	Two H3/70W white working lamps high mounted on the back of cab		
<input type="checkbox"/> WLC-PKH	Preparation kit, cables and switch for high mounted working lamps back of cab		
<input type="checkbox"/> WLC-PKL	Preparation kit, cables and switch for low mounted working lamps back of cab		
<input type="checkbox"/> WLC-PKLH	Preparation kit - cables and switch for low and high mounted working lamps back of cab.		
<input checked="" type="checkbox"/> ECBB-BAS	Body builder electrical centre without body builder module		
<input type="checkbox"/> ECBB-HIG	Body builder electrical centre with body builder module		
<input type="checkbox"/> BBCHAS1	One 7-pole connector for Body builder interface		
<input type="checkbox"/> BBCHAS3	Three 7-pole connectors for Body builder interface		
<input type="checkbox"/> BEPR-T2	Body builder electrical software preparation for tipper with remote control		
<input type="checkbox"/> EXSTER	External steering control, with VDS and bodybuilder module		
<input type="checkbox"/> TD-BAS	Trailer detection WITHOUT LED sensing		
<input checked="" type="checkbox"/> TD-LED	Trailer detection with LED sensing		
<input type="checkbox"/> AUXL-SPK	Electrical preparation kit - wiring and switch for snow plough lights		
<input type="checkbox"/> TAILPRE2	Tail lift preparation kit, wireless remote operation		
<input type="checkbox"/> TAILPREP	Taillift preparation kit - cab switch and warning in driver display		

Standard Equipment

Optional Equipment

For more detailed information about cab and powertrain equipment, please refer to separate specification sheets.

For all possible options and combinations of options please consult your Volvo sales contact who can create a specification to match your requirements using the Volvo Sales Support system (VSS).

The factory reserves the right to modify design and change equipment without previous notification. The specification can vary from country to country.

MODEL RANGE

FM LNG 4x2 Tractor - Rear Air Suspension - Contact Regional Business Manager before

- AESW2** Two Body builder bistable electrical switches (marked AUX1 / AUX2)
- AESW2PK** 2 Body builder bistable el.switches (marked AUX1/AUX2) and prep. for 4 more switches
- AUXSW-4** Wiring for 4 extra switches (from Body builder electrical centre to switch positions)

DELIVERY SERVICES

- TGW-4GWL** GSM/GPRS/4G modem, LTE & WLAN for telematics gateway
- FMS-PK** Fleet Management System gateway

VOLVO

Volvo Truck Corporation
volvotrucks.com