

MODEL RANGE

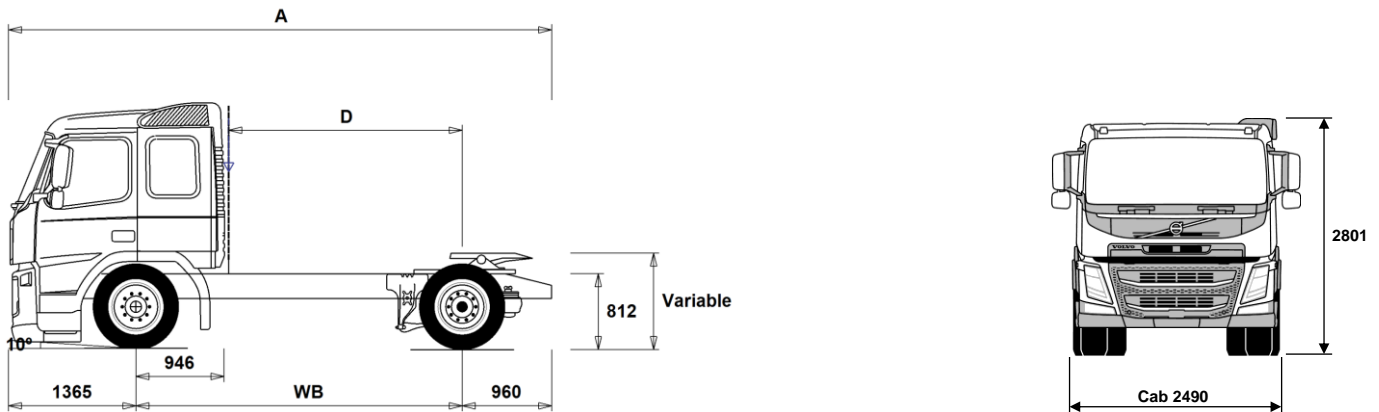

Volvo Trucks. Driving Progress

FM 13 4x2 Tractor - X-Low - Full Air Suspension FM 42 T3XA



Chassis Dimensions [mm]

WB Wheelbase	3500	3600	3800
A Overall Chassis Length	5825	5925	6125
D Center of rear axle to back of cab	2504	2604	2804
F Fifth Wheel Position (EC Directive 96/53)	375	375	375

Chassis Weights [kg]

Front Axle	4395	4390	4400
Rear Axle	1820	1820	1840
Kerb Weight	6215	6210	6240

Turning Diameter [mm]

Turning Circle Diameter Kerb to Kerb	12700	13000	13600
Turning Circle Diameter Wall to Wall	14200	14500	15100

Plated Weights [kg]

	Plated	Design
Gross Vehicle Weight	18000	18600
Gross Combination Weight	40000	44000
Front Axle	6700	7100
Rear Axle	11500	11500

Important Notes

Chassis Dimensions

Cab Height: +416 mm for CAB-HSLP, -169 mm for CAB-LSLP, +554 mm for CAB-XHSL.

Front Axle to Back of Cab: -424 mm for CAB-DAY, -6 mm for CAB-LSLP.

D-measure includes a front clearance of 50 mm and for rigid trucks also a subframe of 100 mm.

Height can vary ± 20 mm for leaf and ± 10 mm for air suspension.

All dimensions are for unladen chassis and any tag axles down.

Weight and dimensions are based upon the following tyres:

Front Axle Tyres: 295/60R22.5

Drive Axle Tyres: 295/60R22.5

Chassis weight includes oil, water, AdBlue, 0 litres fuel and without driver. Kerb weight can vary $\pm 3\%$.

Turning diameters are theoretically calculated.

Legal weights can differ from country to country.

For more detailed weight information, including optional equipment weights, ask your Volvo sales contact to enter your specification into the Volvo Weight Information system (WIS).

Do NOT use this drawing for bodybuilding. Refer to Volvo Bodybuilder Instructions and chassis assembly drawing FM42T3XA.

MODEL RANGE

FM 13 4x2 Tractor - X-Low - Full Air Suspension FM 42 T3XA

TRUCK USE

- **RC-SMOOT** Operating class highway

CORE COMPONENTS

- **CHH-XLOW** Chassis frame height extra low - For a specific loading height always check the unique BEP chassis drawing
- **RAD-G4** RAD-G4 - 4x2 Air - Lite
- **RAD-GR** RAD-GR- 4x2 Air - High
- **FM-DAY** Day cab - with steel safety cage design
Designed and built to Swedish impact and ECE R29 regulations
- **FM-HSLP** Globetrotter cab - with steel safety cage design
Designed and built to Swedish impact and ECE R29 regulations
- **FM-LSLP** Low sleeper cab - with steel safety cage design
Designed and built to Swedish impact and ECE R29 regulations
- **FM-SLP** Sleeper cab - with steel safety cage design
Designed and built to Swedish impact and ECE R29 regulations
- **FM-XHSL** Globetrotter LXL cab - with steel safety cage design
Designed and built to Swedish impact and ECE R29 regulations
- **EU6SCR** Emission level - Euro 6
- **D13 420S** D13K420 12.8 litre engine developing 420hp at 14-1800rpm.
Peak torque 2100Nm at 860 -1400rpm.
- **D13 460S** D13K460 12.8 litre engine developing 460hp at 14-1800rpm.
Peak torque 2300Nm at 900-1400rpm.
- **D13 500S** D13K500 12.8l engine developing 500hp at 14-1800rpm.
Peak torque 2500Nm at 1000-1400rpm.
- **D13K420** D13K420 - 420hp engine
- **D13K460** D13K460 - 460hp engine
- **D13K500** D13K500 - 500hp engine
- **EBR-EPG** Exhaust brake controlled by steering column switch
- **EBR-EPGC** Exhaust pressure governor for I shift gearbox
- **EBR-VEB+** Volvo engine brake + and exhaust pressure governor, enhanced performance from additional exhaust rocker control. Retardation 375kW
- **AT2412F** AT2412F 12-speed "I-shift" automated mechanical gearbox suitable for gross train weights up to 44tonne only refer to sales engineering when used in conjunction with a PTO
- **AT2612F** AT2612F 12-speed "I-shift" automated mechanical gearbox suitable for gross train weights up to 60tonne only refer to sales engineering when used in conjunction with a PTO
- **SPO2812** SPO2812 - 12 speed I-shift Dual Clutch automated mechanical gearbox GCW 60tonne
- **RSS1344E** RSS1344E single reduction rear axle with differential lock - design GCW 44tonne
- **RSS1352A** RSS1352A single reduction 13 tonne rear axle with differential lock - design GCW 52 tonne
- **RSS1356** RSS1356 single reduction rear axle with differential lock - design GCW 56 tonne

PACKAGES

- **LHFP-VE** Long Haul Fuel Economy driving package
- **LHFP-VE+** Long Haul Fuel Economy plus driving package
- **DRIVEFM** Cab Package: Drive
- **DRIVEFM+** Cab Package: Drive +
- **BEDFM** One bed resting package
- **AUDHIG** High Power Audio system: RDS radio with CD player - also playing MP3/WMA files from CD -, with integrated bluetooth phone and USB/Line inputs. FM/AM antenna, speakers in dashboard, doors, and sleeping compartment.
- **MEDIA** AM/FM Bluetooth radio without CD player.
USB and Aux line inputs.
Speakers in dashboard, doors, and sleeping compartment.
7" touch screen with personal and apps.

■ Standard Equipment

□ Optional Equipment

For more detailed information about cab and powertrain equipment, please refer to separate specification sheets.

For all possible options and combinations of options please consult your Volvo sales contact who can create a specification to match your requirements using the Volvo Sales Support system (VSS).

The factory reserves the right to modify design and change equipment without previous notification. The specification can vary from country to country.

- **MEDIADF** AM/FM Bluetooth radio without CD player.
USB and Aux line inputs.
Speakers in dashboard, doors, and sleeping compartment.
7" touch screen with personal and professional apps.
Dynafleet vehicle on-board data display with office internet support.
- **MEDIANAV** AM/FM Bluetooth radio without CD player.
USB and Aux line inputs.
Speakers in dashboard, doors, and sleeping compartment.
7" touch screen with personal and professional apps.
Truck based satellite navigation (live updates not included)
- **MEDIANDF** AM/FM Bluetooth radio without CD player.
USB and Aux line inputs.
Speakers in dashboard, doors, and sleeping compartment.
7" touch screen with personal and professional apps.
Truck based satellite navigation (live updates not included)
Dynafleet vehicle on-board data display with office internet support.

- **VISI15** Visibility Package
- **VISI15+** Visibility Plus Package

- **ASAF15** Active Safety Package

CHASSIS

- **FST-AIR** Front suspension type - air
- **FAL7.1** Front axle design capacity 7.1 tonnes
- **FAL7.5** Front axle design capacity 7.5 tonnes
- **FSTAB** Front anti-roll bar
- **RAL11.5** Rear axle design capacity 11.5 tonnes
- **RSTAB1** Rear anti-roll bar
- **RSTAB3** Rear stiff anti-roll bar
- **ASF-DL1** Air suspension with 1 driving level
- **ASF-DL3** Air suspension with 3 driving levels
- **ACTST-TO** Volvo Dynamic Steering (VDS) with with extra electronic pump and torque overlay
- **ASFE-BAS** Active steering feature - Basic - Volvo Dynamic Steering only
- **ASFE-OG** Active steering feature - Volvo Dynamic Steering with stability assist - oversteer
- **ASFE-PO** Active steering feature - Volvo Dynamic Steering with personal settings and stability assist
- **ASFE-PS** Active steering feature - Volvo Dynamic Steering with personal settings
- **PSS-SING** Single power steering system
- **PSP-FIX** Power steering pump with fixed displacement
- **PSP-VAR** Power steering pump with variable displacement
- **EBS-MED** EBS medium package including "hill" hold function
- **AUXPARK** Additional spring parking brakes
- **FRAME266** Frame rail section external height 266 mm
- **FST7070** Frame thickness - web and flange 7.0mm
- **FST8080** Frame thickness - web and flange 8.0mm
- **BBOX-L** Battery box located on left hand side
- **BATS-D** Dual energy battery system - 2 living batteries and 2 starter batteries.
- **BATS-S** Single energy battery system (2 batteries)
- **2BAT210B** 2 x 210 Ah capacity Gel batteries
- **2BATT170** 2 x 170 Ah capacity batteries
- **2BATT225** 2 x 225 Ah capacity batteries
- **BATTAMP** Battery voltage and ampere gauge
- **BATTIND** Battery charge indication
- **ADR2** ADR package for transportation of dangerous goods on road (Note does NOT include safe loading pass package if required this is quoted separately)
- **MSWI-A** Main switch - ADR switch circuit shut down
- **MSWI-C** Main switch - Chassis mounted toggle switch by battery box

MODEL RANGE

FM 13 4x2 Tractor - X-Low - Full Air Suspension FM 42 T3XA

- MSWI-R** Main switch - Key fob operated remote controlled
 - R315A56** Right aluminium 560 mm D-shaped fuel tank, 315 litres volume
Min volume 255l
Max volume 630l
 - UL-FUEL** Without left fuel tank
Min volume 160l
Max volume 505l
 - ADTP-BC** AdBlue tank behind/under cab on right hand side
 - ADTP-L** AdBlue tank on left hand side
 - ADTP-R** AdBlue tank on right hand side
 - ADB048** AdBlue tank usable volume 48 litres
 - ADB050** AdBlue tank usable volume 50 litres - under cab
 - ADB068** AdBlue tank usable volume 68 litres
 - ADTC-BF** AdBlue tank cover with satin alloy look decorative cover
 - FCAP-L** Locking fuel filler cap
 - FUFF-AS** Fuel filling anti-spillage device
 - FUFF-ATS** Fuel filling anti-theft and anti-spillage devices
 - ESH-LEFT** Horizontal silencer, left exhaust outlet
 - ESH-REAR** Horizontal silencer, rear exhaust outlet
 - ESH-VERT** Horizontal silencer, vertical exhaust outlet
 - EXST-SSP** Stainless steel exhaust stack - NOT polished
 - WHC-FIX1** One fixed wheel chock
 - WHC-FIX2** Two fixed wheel chocks
 - WHC-FOL1** One foldable wheel chock
 - WHC-FOL2** Two foldable wheel chocks
 - WHCP-F** Wheel chock(s) stored in the front part of the vehicle
 - WHCP-M** Wheel chock(s) stored in the middle part of the vehicle
 - WHCP-T** Transport mounted wheel chock(s) stored in cab outer luggage locker
 - CHAIN-S** Snow chains
 - TOWF-NO1** One front towing device
 - TOWF-NO2** Two front towing devices
 - RFEC-B** Rear frame end, bent down - standard for tractor vehicles
 - TREL15** Single 15 pole electrical trailer connector - ADR certified
 - TREL7** 7 pole - 24N trailer electrical suzie
 - TREL7-7** 24N and 24S trailer electrical suzies
 - TBC-DUO** Duomatic type air line connectors
 - TBC-EC** Palm coupling type air line connectors
 - TBC-GBR** 'C' and 'CA' type air line connectors
 - TRBR-HCF** Full pressure hand controlled trailer brake
 - TRBR-STA** Stationary trailer brake control
 - TRB-STRE** Stretch Brake - Automatic low speed trailer brake activation to avoid jack-knifing and improve steerability
 - RFEND-B** Three piece EC approved rear mud wings and spray flaps
 - RFH-BAS** Basic rear wing height
 - RFH-HIG** High rear wing height - higher wing tops
 - RFH-LOW** Lower rear wing height - shallower wing tops
 - ATANK-AL** Aluminium air tanks
 - ATANK-ST** Steel air tanks
 - TL-LED** Rear lights LED
 - BLIGHT-E** Emergency brake light
- ### WHEELS & TYRES
- RT-AL** Alcoa brushed aluminium rims with standard holes for long stud fixing on all axles
 - RT-ALDP** Alcoa Dura-Bright EVO aluminium rims with standard holes long stud fixing on all axles, requires cleaning with a ph neutral solution - washing up liquid.
 - RT-ALDPD** Alcoa Dura-Bright EVO aluminium rims with countersunk holes for short stud fixing on all axles, requires cleaning with a ph neutral solution - washing up liquid.
 - RT-ALDU** Alcoa brushed aluminium rims with countersunk holes for short stud fixing on all axles
Steel rims on all axles
 - RT-STEEL** stud fixing on all axles
Steel rims on all axles
 - WCAP** Aerodynamic hub caps
 - COREC002** Continental ECOPLUS HS3/HD3 - Energy rating B or C depending on size
 - GYREC001** Goodyear FUELMAX S/HL/D - Energy rating B or C depending on size
 - MIREC003** Michelin X-LINE Energy - Fuel tyre Recommendation 3
 - SPWT-D** Spare wheel & tyre with rear tyre pattern
 - SPWT-F** Spare wheel & tyre with front tyre pattern
 - SWCP-T** Spare wheel supplied temporarily strapped to chassis
 - SWCP-TP** Temporary spare wheel carrier on top of chassis frame
 - JACK-12T** 12 tonne bottle jack
 - TOOL-BAS** Basic Toolkit
 - TOOLKIT** Complete tool kit
 - INFLAHOS** Tyre inflation hose
 - GAUGE-TP** Tyre pressure gauge
- ### DRIVELINE EQUIPMENT
- TRAP-HD** Reinforced gearbox application
 - TP-CON** Construction Package
 - TP-DIST** Distribution Package
 - TP-LONG** Long Haul Package
 - AMSO-AUT** Enhanced I-shift software with manual shift available in auto mode and kickdown facility on accelerator pedal
 - AVO-ENH** Enhanced software for off road driveability and starting
 - APF-ENH** I-shift enhanced PTO functions
 - RET-TH** Gearbox mounted retarder
 - RET-TPT** Hydraulic Retarder for Powertronic gearbox
 - TC-MAOH2** Extra high performance transmission oil cooler - air to oil with front mounted radiator
 - TC-MWO** Basic transmission oil cooler - water to oil
 - 2COM1100** Two cylinder, air compressor, 1100 litres per minute
 - 2COMP900** Two cylinder, air compressor, 900 litres per minute
 - CLU-AIRC** Clutchable air compressor
 - AIRIN-HI** Roof mounted air intake behind cab on left hand side
 - AIRIN-LO** Low level air intake behind cab on left hand side
 - ACL1ST-S** Two stage air filter
 - 24AL110B** 110 amp alternator
 - 24AL120B** 120 amp alternator
 - 24AL150B** 150 amp alternator
 - CCV-C** Closed crankcase engine ventilation
 - CCV-O** Open crankcase engine breather
 - CCV-OX** Closed crankcase ventilation for cold markets
 - PRIM-EL** Electrical priming pump
 - PRIM-MAN** Manual priming pump
 - FUEQ-EH** Fuel line electric heater
 - AF-R** Hot fuel recirculation heated fuel filter
 - FUEFE2LW** Large engine mounted dual fuel filter with water separator
 - FUEFE2SW** Small engine mounted dual fuel filter with water separator
 - EST-AID** Air inlet manifold starting heater element
 - 220EBH15** 220V/1.5Kw electric engine block heater
 - PTER-100** Rear engine mounted power-take-off with DIN 100 / ISO 7646 flange
 - PTER-DIN** Rear engine mounted PTO with DIN5462 (female) splined shaft for a close coupled pump.
Models with 3 steering axles will use this to drive the steering pump (AUXPSP)
 - PTER1400** Rear engine mounted power-take-off with SAE 1410 flange

Standard Equipment

Optional Equipment

For more detailed information about cab and powertrain equipment, please refer to separate specification sheets.

For all possible options and combinations of options please consult your Volvo sales contact who can create a specification to match your requirements using the Volvo Sales Support system (VSS).

The factory reserves the right to modify design and change equipment without previous notification.
The specification can vary from country to country.

MODEL RANGE

FM 13 4x2 Tractor - X-Low - Full Air Suspension FM 42 T3XA

- HPE-F101** Parker F1-101, engine mounted, fixed displacement, single flow, engine mounted hydraulic pump
- HPE-F41** Parker F1-41, engine mounted, fixed displacement, single flow, engine mounted hydraulic pump
- HPE-F51** Parker F1-51, engine mounted, fixed displacement, single flow, engine mounted hydraulic pump
- HPE-F61** Parker F1-61, engine mounted, fixed displacement, single flow, engine mounted hydraulic pump
- HPE-F81** Parker F1-81, engine mounted, fixed displacement, single flow, engine mounted hydraulic pump
- HPE-T53** Parker F2-53/53, engine mounted, Fixed displacement, Twin flow engine mounted hydraulic pump
- HPE-T70** Parker F2-70/35, engine mounted, Fixed displacement, Twin flow engine mounted hydraulic pump
- HPE-V45** Parker VP1-45, variable displacement, single flow, engine mounted hydraulic pump
- HPE-V75** Parker VP1-75, variable displacement, single flow, engine mounted hydraulic pump
- PTR-D** Gearbox PTO for plug-in pump, 0.71xeng speed
- PTR-DH** Gearbox driven high speed PTO for one plug-in hydraulic pump
- PTR-DM** Gearbox driven medium speed PTO for one plug-in hydraulic pump
- PTR-F** Gearbox driven PTO with rear flange connection
- PTR-FH** Gearbox driven high speed PTO with SAE drive flange
- PTR-FL** Gearbox driven low speed PTO with SAE drive flange
- PTRD-D** Gearbox driven HIGH SPEED PTO for two plug-in hydraulic pumps
- PTRD-D1** PTRD-D1 Gearbox driven HIGH SPEED PTO (1 SAE flange & 1 plug-in hydraulic pump)
- PTRD-D2** Gearbox driven HIGH SPEED PTO (2 SAE flanges & 1 plug-in hyd pump)
- PTRD-F** PTO with 1 DIN + 1 flange connection rear, manual gearbox
- HPG-F101** Parker F1-101 gearbox mounted, fixed displacement, single flow, hydraulic pump
- HPG-F41** Parker F1-41 gearbox mounted, fixed displacement, single flow, hydraulic pump
- HPG-F51** Parker F1-51 gearbox mounted, fixed displacement, single flow, hydraulic pump
- HPG-F61** Parker F1-61 gearbox mounted, fixed displacement, single flow, hydraulic pump
- HPG-F81** Parker F1-81 gearbox mounted, fixed displacement, single flow, hydraulic pump
- EIDLESD** Engine idle shut down
- DTRI-PER** Dashboard in darker peregrine greyish brown. Steering wheel grey and door panels in light beige for FH and black for FH16.
- STWPOS-R** RIGHT HAND DRIVE
- STWM-LE** Leather steering wheel
- STGW-AD2** Adjustable steering wheel with neck tilt
- STGW-ADJ** Adjustable steering wheel
- AIRBAG** SRS Driver's air bag
- DRC-AMII** DPF Regeneration control switch - for manual and switching off regeneration
- 1DAYDIG2** Continental VDO DTCO 4.0 smart tachograph
This tachograph can ONLY offer remote download if the option of Dynafleet or an FMS gateway has been specified with this order.
- 1DAYDIGP** Continental VDO DTCO 3.0 digital tachograph
For vehicles with long lead time - this includes prep kit for the retrofit of DTCO 4.0 tachograph.
For updating to new legal demand for trick registration from 15th June 2019.
This tachograph can ONLY offer remote download if the option of Dynafleet or an FMS gateway has been specified with this order.
- ARSL** Additional road speed limit - switch in dashboard
- CRUIS-E** Eco cruise control (with eco-roll and I-cruise, controls in steering wheel)
- CRUISEC** Cruise control, standard
- ESP-BAS1** Electronic Stability Control
- ESPC-RO** ESP (Electronic Stability Program) functionality control - Reduced / Off
- HWSS-ACB** Adaptive cruise control ACC with forward collision warning and AEBs advanced emergency brake system
- HWSS-FCB** Forward collision warning with AEBs advanced emergency brake system
- LSS-DW** Lane departure-warning system
- LCS** Lane change support
- DAS-W** Driver Alert Support system
- RSENS-W** Rain sensing windscreen wipers
- CU-ECC** Electrically controlled air conditioning with sun sensor
- CU-ECC2** Electrically controlled air conditioning with sun sensor, mist sensor, air quality sensor and carbon filter
- CU-MCC** Climate unit with manual controlled air conditioning
- IMMOBIL** Thatcham H2 approved immobiliser
- ALARM-B** Thatcham H1 approved vehicle alarm - Cab only
- ALARM-E** Enhanced vehicle alarm - Thatcham H1 approved - Cab plus external sensor for body/trailer
- ALCOLOCK** Alcolock
- BUPMON** Back up monitor with built in 7" screen on dash and one colour camera supplied loose for fitment by bodybuilder.
Can accommodate up to 4 cameras for TfL Safe Scheme, CLOCS and FORS.
- PHONE-PK** Telephone preparation kit (antenna, antenna attachm. cable incl.)
- WLIFT-AD** Electrical window lift, automatic up/down driver side
- WLIFT-EB** Electrical window lift
- WLIFT-ME** Mechanical window lift
- ISUNS-BS** Side interior sun visor on both sides
- ISUNS-DS** Driver's side interior sun visor
- ISUNF-B** Interior front sun visor without mirror
- ISUNF-MD** Interior front sun visor with mirror on driver side
- ISUNF-RE** Electrically operated textile interior sun blind
- ISUNF-RM** Manually operated textile interior sun blind
- ADFS** Two extra DIN slots in front shelf - can be fitted with card or drawer available as an accessory
- BUPALARM** Reverse alarm
- RTOLL-PK** Road toll PREPARATION kit for trucks operating with "Toll Collect" in Germany
- LOADIND** Load indicator with central dashboard display
- REMC-MF** Multi-functio wireless remote control
- FIREXT3S** 3kg fire extinguisher mounted on seat base
- WARNVEST** High visibility warning vest - no sleeves
- AIDKIT** First aid kit
- AIDKIT1B** First aid kit
- WARNLAMP** Portable warning lamp
- LAMP-IN** Inspection lamp
- BULBKIT** Bulb and fuse kit
- WRITEPAD** Writing pad
- UPHTRI10** Seats: Black embossed textile insert with light grey sides, black vinyl side bolster with blue vinyl side insert.
Interior trim: Raven black bunk and curtains & blue textile side walls
- UPHTRI11** Seats: Light grey embossed textile insert, black raven metallic vinyl bolster with red vinyl side insert.

Standard Equipment

Optional Equipment

For more detailed information about cab and powertrain equipment, please refer to separate specification sheets.

For all possible options and combinations of options please consult your Volvo sales contact who can create a specification to match your requirements using the Volvo Sales Support system (VSS).

The factory reserves the right to modify design and change equipment without previous notification. The specification can vary from country to country.

MODEL RANGE

FM 13 4x2 Tractor - X-Low - Full Air Suspension FM 42 T3XA

<input type="checkbox"/>	Interior trim: Raven black bunk and curtains & grey vinyl side walls	<input type="checkbox"/>	ETSB-S	recessed into tunnel on right hand side Storage on engine tunnel - recessed into tunnel on right hand side	
<input type="checkbox"/>	UPHTRI12 Seats: Blue soft textile insert, black vinyl bolster. Interior trim: Raven black bunk and curtains & blue textile side walls	<input type="checkbox"/>	RUS-BAS RUS-HIG	Rear cab upper storage 154 litres - 300 mm high Rear cab upper storage 245 litres - 440 mm high	
<input type="checkbox"/>	UPHTRI13 Seats: Dark grey leather insert and black leather bolster. Interior trim: Raven black bunk and curtains & grey vinyl side walls	<input type="checkbox"/>	TABLE	Folding and height adjustable table - on lower bunk	
<input type="checkbox"/>	UPHTRI14 Seat: Dark grey leather insert and black leather bolster. Interior trim: Raven black bunk and curtains & blue textile side walls	<input type="checkbox"/>	REF-ICPK REFR-RUS	Fridge: engine tunnel mounted preparation kit Fridge: 28 litre rear upper wall mounted with dividers	
<input checked="" type="checkbox"/>	DST-CF4	Driver seat, comfort, suspended, belt in seat	<input type="checkbox"/>	MICRO-PK	Preparation kit for microwave oven (wiring)
<input type="checkbox"/>	DST-CF5	Driver seat, comfort, suspended, belt in seat, electrically heated	<input type="checkbox"/>	BOTH-D	One bottle holder under dashboard centre section
<input type="checkbox"/>	DST-CF6	Driver seat, comfort, suspended, belt in seat, electrically heated, ventilated	<input type="checkbox"/>	COFMA-PK	Coffee maker, preparation kit.
<input type="checkbox"/>	SBD-RED	Red seat belts	<input checked="" type="checkbox"/>	INLI-BAS	Interior white LED lights - basic
<input type="checkbox"/>	SBPRE-DS	Driver seat belt pretensioner	<input type="checkbox"/>	INLI-NL	Interior white and red night LED light with no dimmer
<input checked="" type="checkbox"/>	PST-BAS1	Passenger seat - Fixed non suspended fold up with seatbelt mounted in cab	<input type="checkbox"/>	INLI-NLD	Interior white and red night LED light with dimmer
<input type="checkbox"/>	PST-BENC	Bench passenger seat	<input type="checkbox"/>	ARL-FLEX	Two flexible reading lamps (snake lamps)
<input type="checkbox"/>	PST-CF4	Passenger seat - Comfort suspended with seatbelt mounted in seat	<input type="checkbox"/>	RH-ECS	Glass roof & escape hatch - Electrically operated
<input type="checkbox"/>	PST-CF5	Passenger seat - Comfort suspended & heated with seatbelt mounted in seat	<input type="checkbox"/>	RH-EE	Without roof hatch - Tinted glass emergency exit ONLY
<input type="checkbox"/>	PST-STD2	Passenger seat - Fixed non suspended with seatbelt mounted in cab	<input type="checkbox"/>	RH-ETR	Glass roof & escape hatch - Electrically operated, tinted glass with rear opening
<input type="checkbox"/>	PST-STD4	Passenger seat - Standard suspended with seatbelt mounted in cab	<input type="checkbox"/>	RH-MSR	Steel roof & escape hatch - Manually operated with rear opening
<input type="checkbox"/>	SBPRE-PS	Passenger seat belt pretensioner	<input type="checkbox"/>	RH-MTR	Glass roof & escape hatch - Manually operated, tinted glass with rear opening
<input type="checkbox"/>	ARM-DBPS	Two armrests on driver seat and one (outer) on passenger seat	<input checked="" type="checkbox"/>	URH	Without roof hatch
<input type="checkbox"/>	ARMRE-BB	Two armrests on both driver and passenger seat.	<input type="checkbox"/>	SWIND-BS	Extra side window on both sides behind "B" pillar
<input type="checkbox"/>	ARMRE-DB	Two armrests, on driver seat only	<input type="checkbox"/>	SWIND-PS	Rear side window, passenger side
<input type="checkbox"/>	ARMRE-PB	Two armrests, on passenger seat only	<input type="checkbox"/>	VANMIR	Vanity mirror in front shelf
<input type="checkbox"/>	ARMRE-PS	Single armrest (next to driver) on passenger seat	<input type="checkbox"/>	AS-FUS	Extra shelf in front upper storage compartments
<input type="checkbox"/>	ARU-BAS	Vinyl upholstered armrest	<input type="checkbox"/>	INFOT-PK	Preparation kit for the mounting of a flat screen TV in cab above the driver's door, includes bracket, electrical and speaker connections
<input type="checkbox"/>	ARU-LEA	Leather upholstered armrest	CAB EXTERIOR		
<input checked="" type="checkbox"/>	FMAT-RUB	Rubber floor mats	<input checked="" type="checkbox"/>	PAICS-B	Basic cab paint - mirrors, sunvisor, instep and bumper supplied in natural finish - grey
<input type="checkbox"/>	FMAT-TX2	Textile and rubber floor mats	<input type="checkbox"/>	PAICS-C	Complete cab - mirrors, insteps, sunvisor, and bumper finished in cab colour
<input type="checkbox"/>	LBK-RES	Foldable rest bunk	<input checked="" type="checkbox"/>	GLAS-TIN	Tinted windows.
<input checked="" type="checkbox"/>	LBK70	Lower bunk 700 x 2000 mm, fixed	<input type="checkbox"/>	AWIND-RF	Rear window
<input type="checkbox"/>	ULBK	Without lower bunk	<input type="checkbox"/>	DGLAS-L	Laminated door glass
<input type="checkbox"/>	MATL-FI	Firm lower bunk pocket sprung mattress	<input checked="" type="checkbox"/>	LOCK-MAN	Manual door locking
<input checked="" type="checkbox"/>	MATL-SF	Lower flexizone mattress - semi-firm, pocket springs up to 100kg - 16 stone	<input type="checkbox"/>	LOCK-MRP	Manual door locking with internal remote control (from driver side) of passenger door
<input type="checkbox"/>	MATL-SO	Lower flexizone mattress - soft, pocket springs up to 85kg - 13.5 stone	<input type="checkbox"/>	LOCK-REM	Central locking with remote control
<input type="checkbox"/>	OLMAT-BA	35mm mattress overlay protector	<input checked="" type="checkbox"/>	BUMP-B	Plastic front bumper
<input type="checkbox"/>	OLMAT-PR	50mm premium mattress overlay protector	<input type="checkbox"/>	BUMP-B2	Steel front bumper
<input type="checkbox"/>	TBK60F	Fixed foldable top bunk 600 x 1900mm	<input checked="" type="checkbox"/>	BUGNET	Insect screen in front of radiator
<input type="checkbox"/>	TBK70F	Fixed foldable top bunk 700 x 1900mm	<input type="checkbox"/>	CTILT-P-E	Electrically operated hydraulic cab tilt
<input type="checkbox"/>	PH-CAB2	1.8kW Air to air night heater	<input checked="" type="checkbox"/>	CTILT-P-M	Manually operated hydraulic cab tilt
<input type="checkbox"/>	PH-ENGCA	Engine and cab night heater	<input type="checkbox"/>	FCABS-A	Front cab suspension - Air
<input type="checkbox"/>	PH-SS	Short stop heater	<input checked="" type="checkbox"/>	FCABS-M	Front cab suspension - Mechanical spring
<input type="checkbox"/>	SLCP-BAS	Basic sleeper control panel - includes interior light, parking heater, roof hatch and door lock	<input type="checkbox"/>	RCABS-A	Rear cab suspension - Air
<input type="checkbox"/>	SAFE	Safe box for driver's personal items	<input checked="" type="checkbox"/>	RCABS-M	Rear cab suspension - Mechanical spring
<input type="checkbox"/>	ETSB-F	Storage on engine tunnel - on front top	<input type="checkbox"/>	MIRCOMF2	Electrically heated and operated FMX style main and wide-angle mirror on both sides, with manual passenger kerb mirror. To increase direct vision to the side the main mirrors have no cowlings
<input type="checkbox"/>	ETSB-FR	Storage on engine tunnel - on front top and at rear cab wall	<input type="checkbox"/>	MIRCOMFM	Electrically heated and operated main with manual wide-angle mirror - both sides - and passenger kerb mirror
<input type="checkbox"/>	ETSB-FRS	Storage on engine tunnel - on front top & at rear cab wall & storage recessed into tunnel on right hand side	<input type="checkbox"/>	MIRSTD2	Electrically heated - FMX - main with wide angle mirror on both sides and kerb view mirror on passenger side, to increase direct vision to the side the main mirrors have no cowlings
<input type="checkbox"/>	ETSB-FS	Storage on engine tunnel - on front top and storage recessed into tunnel on right hand side			
<input type="checkbox"/>	ETSB-R	Storage on engine tunnel - box at rear cab wall			
<input type="checkbox"/>	ETSB-RS	Storage on engine tunnel - at rear cab wall and storage			

■ Standard Equipment

□ Optional Equipment

For more detailed information about cab and powertrain equipment, please refer to separate specification sheets.

For all possible options and combinations of options please consult your Volvo sales contact who can create a specification to match your requirements using the Volvo Sales Support system (VSS).

The factory reserves the right to modify design and change equipment without previous notification. The specification can vary from country to country.

MODEL RANGE

FM 13 4x2 Tractor - X-Low - Full Air Suspension FM 42 T3XA

- **MIRSTDFM** Electrically heated main mirror with wide angle mirror on both sides and kerb view mirror on passenger side
- **AMIR-F20** Auxiliary front view mirror with a 200mm radius
- **SUNV-H** External smoke grey sunvisor
- **AD-ROOF** Roof air deflector
- **AD-SIDEL** Side air deflector extension panels
- **AD-SIDES** Short cab side air deflector for rigid bodywork
- **HL-BASIC** Halogen H7 head lamps
- **HL-BHID** High intensity Bi-Xenon head lamps
- **HL-DBL** Bi-Xenon high intensity discharge and dynamic head lamps. Dipped beam follows the road, activated by a signal from the steering system.
- **HL-CLEAN** Head lamp cleaner - washer jets
- **HLP-ST** Headlamp protection
- **HL-ADJ** Headlight adjustment - Switch in cab
- **DRIVL2** Two spot lamps
- **UDRIVL** Without auxiliary driving lights
- **FOGL-WC** Front fog lights
- **CL-STAT** Static corner lights
- **ASL-RF2** Two Hella H11 70W spotlamps in sign box - only available with the basic headlight and no lower driving lights.
- **ASL-RFPK** Preparation kit for two spotlamps in sign box
- **BEACOA2F** Two front roof mounted amber beacon rotating warning lamps
- **BEACOA2R** Two rear roof mounted (on accessory bracket) amber beacon flashing warning LED lamps
- **BEACON-P** Roof beacon wire preparation
- **BEACONA4** Four roof mounted (2 front/2 rear) amber beacon rotating warning lamps
- **CABPT-R1** Single outlet for roof mounted accessories
- **CABPT-R2** Twin outlets for roof mounted accessories.
- **SPOTP-F** Spotlamp preparation in front, max 280W
- **SPOTP-R** Spotlamp preparation on roof, max 280W
- **SPOTP-RF** Spotlamp preparation on cab roof and in cab front, max 2x280W
- **ROS-IL2** Preparation kit for illuminated roof sign with switch loose in cab, fit after registration
- **CSGN-GTR** "Globetrotter" headboard logo
- **HORN-F1S** Single tone Jericho air horn chassis mounted
- **HORN-R2S** Two roof mounted air horns
- **ANT-CBR** Roof mounted antenna for CB radio, single aerial
- **ACCBP-AP** Front, middle & rear roof mounted accessory brackets
- **ACCBP-F** Front roof mounted accessory bracket
- **ACCBP-FM** Front & middle roof mounted accessory brackets
- **ACCBP-FR** Front & rear roof mounted accessory brackets
- **ACCBP-M** Middle roof mounted accessory bracket
- **ACCBP-R** Rear roof mounted accessory bracket
- **ACCBP-RM** Rear & middle roof mounted accessory brackets
- **RFCAR-BC** Rear mudwing carrier, back of cab
- **LADDER** Ladder back of cab
- **REFS-TW** White cab conspicuity markings by packed in cab
- **REFS-TY** Yellow cab conspicuity markings by packed in cab
- **5WH140** Fifth wheel leg-height 140 mm
- **5WH150** Fifth wheel leg-height 150 mm
- **5WH160** Fifth wheel leg-height 160 mm
- **5WH175** Fifth wheel leg height 175mm
- **5WH17D37** Fifth wheel leg-height 167 mm to 367mm
- **5WH185** Fifth wheel leg-height 185 mm
- **5WH195** Fifth wheel leg-height 195mm
- **5WH200** Fifth wheel leg-height 200 mm
- **5WH205** Fifth wheel leg-height 205 mm
- **5WH210** Fifth wheel leg-height 210 mm
- **5WH220** Fifth wheel leg-height 220mm
- **5WH230** Fifth wheel leg-height 230 mm
- **5WT-FO14** Fontaine 150SP2 pressed steel fifth wheel
- **5WT-FO15** Fontaine 3000 lightweight cast fifth wheel with 150SF air operated slider - for moderate duty off road. Specified fifth wheel position always gives rearmost position.
- **5WT-JO10** Jost JSK 36 pressed fifth wheel
- **5WT-JO8** Jost JSK 37 cast fifth wheel
- **5WT-JO9** Jost JSK 42 cast fixed fifth wheel
- **5WT-SH** SAF-Holland/+GF+ SK-S 36.20 cast fixed fifth wheel
- **5WLM-B** Basic fifth wheel maintenance standard top plate
- **5WLM-L** Low maintenance fifthwheel with nylon top plate
- **5WL-S1** Fifth wheel lubrication - locking mechanism and top plate
- **5WL-S2** Fifth wheel lubrication - locking mechanism
- **TCIND** Trailer connection indication with sensors for height, kingpin and coupling lock
- **RDECK** Catwalk & step
- **RDECK-M** Rear catwalk 760mm
- **SRWL-PK** Wiring preparation for side & rear work/reverse lamps on side of chassis and a three-position switch, maximum 280W
- **SWL-2RA** Two H3 35W amber rear chassis mounted (LH/RH side) working lamps and a 2-position switch (On/Off)
- **SWL-2RW** Two H3 70W white rear chassis mounted (LH/RH side) working lamps and a 2-position switch (On/Off)
- **SWL-PK** Wiring preparation for side work/reverse lamps on side of chassis and a three-position switch, maximum 280W
- **WL-TA1W** White coupling light
- **WLC-H2A** Two H3/70W working lamps with amber coloured lens high mounted back of cab
- **WLC-H2W** Two H3/70W white working lamps high mounted on the back of cab
- **WLC-PKH** Preparation kit, cables and switch for high mounted working lamps back of cab
- **WLC-PKL** Preparation kit, cables and switch for low mounted working lamps back of cab
- **WLC-PKLH** Preparation kit - cables and switch for low and high mounted working lamps back of cab.
- **ECBB-BAS** Body builder electrical centre without body builder module
- **ECBB-HIG** Body builder electrical centre with body builder module
- **BBCHAS1** One 7-pole connector for Body builder interface
- **BBCHAS3** Three 7-pole connectors for Body builder interface
- **BEPR-T2** Body builder electrical software preparation for tipper with remote control
- **EXSTER** External steering control, with VDS and bodybuilder module
- **TD-BAS** Trailer detection WITHOUT LED sensing
- **TD-LED** Trailer detection with LED sensing
- **AUXL-SPK** Electrical preparation kit - wiring and switch for snow plough lights
- **TAILPRE2** Tail lift preparation kit, wireless remote operation
- **TAILPREP** Taillift preparation kit - cab switch and warning in driver display
- **AESW2** Two Body builder bistable electrical switches (marked AUX1 / AUX2)
- **AESW2PK** 2 Body builder bistable el.switches (marked AUX1/AUX2) and prep. for 4 more switches
- **AUXSW-4** Wiring for 4 extra switches (from Body builder electrical centre)

■ Standard Equipment

□ Optional Equipment

For more detailed information about cab and powertrain equipment, please refer to separate specification sheets.

For all possible options and combinations of options please consult your Volvo sales contact who can create a specification to match your requirements using the Volvo Sales Support system (VSS).

The factory reserves the right to modify design and change equipment without previous notification. The specification can vary from country to country.

MODEL RANGE

FM 13 4x2 Tractor - X-Low - Full Air Suspension FM 42 T3XA

to switch positions)

DELIVERY SERVICES

- **TGW-4GWL** GSM/GPRS/4G modem, LTE & WLAN for telematics gateway
- **FMS-PK** Fleet Management System gateway

VOLVO

Volvo Truck Corporation
volvotrucks.com