

MODEL RANGE

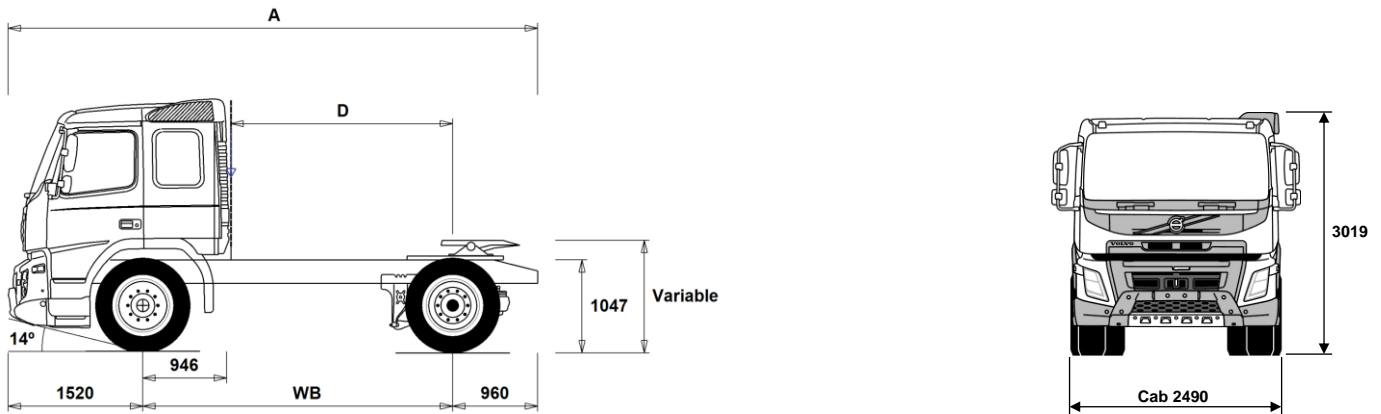

Volvo Trucks. Driving Progress

FMX13 4x2 Tractor - Rear Air Suspension FM 42 T3HAX



Chassis Dimensions [mm]

WB Wheelbase	3500	3600	3700	3800
A Overall Chassis Length	5980	6080	6180	6280
D Center of rear axle to back of cab	2504	2604	2704	2804
F Fifth Wheel Position (EC Directive 96/53)	525	525	525	525

Chassis Weights [kg]

Front Axle	4525	4520	4525	4525
Rear Axle	1835	1840	1850	1855
Kerb Weight	6360	6360	6375	6380

Turning Diameter [mm]

Turning Circle Diameter Kerb to Kerb	12700	13100	13400	13700
Turning Circle Diameter Wall to Wall	14200	14500	14800	15100

Plated Weights [kg]

	Plated	Design
Gross Vehicle Weight	18000	20100
Gross Combination Weight	40000	44000
Front Axle	7100	7100
Rear Axle	11500	13000

Important Notes

Chassis Dimensions

Cab Height: +416 mm for CAB-HSLP, +554 mm for CAB-XHSL.
Front Axle to Back of Cab: -424 mm for CAB-DAY.

D-measure includes a front clearance of 50 mm and for rigid trucks also a subframe of 100 mm.

Height can vary ± 20 mm for leaf and ± 10 mm for air suspension.

All dimensions are for unladen chassis and any tag axles down. Chassis height used: CHH-HIGH.

Height change when chassis height CHH-MED,FRAME266: 0 mm.

Weight and dimensions are based upon the following tyres:

Front Axle Tyres: 315/80R22.5
Drive Axle Tyres: 315/80R22.5

Chassis weight includes oil, water, AdBlue, 0 litres fuel and without driver. Kerb weight can vary $\pm 3\%$.

Turning diameters are theoretically calculated.

Legal weights can differ from country to country.

For more detailed weight information, including optional equipment weights, ask your Volvo sales contact to enter your specification into the Volvo Weight Information system (WIS).

Do NOT use this drawing for bodybuilding. Refer to Volvo Bodybuilder Instructions and chassis assembly drawing FM42T3HAX.

MODEL RANGE

FMX13 4x2 Tractor - Rear Air Suspension FM 42 T3HAX

TRUCK USE

- RC-ROUGH** Operating class on/off road
- RC-SMOOT** Operating class highway

CORE COMPONENTS

- CHH-HIGH** Chassis height high - N3 "On Road" chassis - For a specific loading height always check the unique BEP chassis drawing
- CHH-MED** Chassis height medium - For a specific loading height always check the unique BEP chassis drawing
- RAD-G4** RAD-G4 - 4x2 Air - Lite
- RAD-GR** RAD-GR- 4x2 Air - High
- FMX-DAY** Day cab - with steel safety cage design
Designed and built to Swedish impact and ECE R29 regulations
- FMX-HSLP** Globetrotter cab - with steel safety cage design
Designed and built to Swedish impact and ECE R29 regulations
- FMX-SLP** Sleeper cab - with steel safety cage design
Designed and built to Swedish impact and ECE R29 regulations
- EU6SCR** Emission level - Euro 6
- D13 420S** D13K420 12.8 litre engine developing 420hp at 14-1800rpm.
Peak torque 2100Nm at 860 -1400rpm.
- D13 460S** D13K460 12.8 litre engine developing 460hp at 14-1800rpm.
Peak torque 2300Nm at 900-1400rpm.
- D13 500S** D13K500 12.8l engine developing 500hp at 14-1800rpm.
Peak torque 2500Nm at 1000-1400rpm.
- D13 540S** D13K540 12.8l engine developing 540hp at 14-1800rpm.
Peak torque 2600Nm at 1000-1450rpm.
- D13K420** D13K420 - 420hp engine
- D13K460** D13K460 - 460hp engine
- D13K500** D13K500 - 500hp engine
- D13K540** D13K540 - 540hp engine
- EBR-EPG** Exhaust brake controlled by steering column switch
- EBR-EPGC** Exhaust pressure governor for I shift gearbox
- EBR-VEB+** Volvo engine brake + and exhaust pressure governor, enhanced performance from additional exhaust rocker control.
Retardation 375kW
- AT2412F** AT2412F 12-speed "I-shift" automated mechanical gearbox suitable for gross train weights up to 44tonne only refer to sales engineering when used in conjunction with a PTO
- AT2612F** AT2612F 12-speed "I-shift" automated mechanical gearbox suitable for gross train weights up to 60tonne only refer to sales engineering when used in conjunction with a PTO
- ATO2612F** ATO2612F 12-speed "I-shift" overdrive automated mechanical gearbox suitable for gross train weights up to 60tonne refer to sales engineering when used in conjunction with a PTO
- PT2606** Powertronic automatic 6-speed gearbox, max. engine torque 2600 Nm, max. permitted GCW 130000 kg
- SPO2812** SPO2812 - 12 speed I-shift Dual Clutch automated mechanical gearbox GCW 60tonne
- RSH1370F** RSH1370F hub reduction rear axle with differential lock - design GCW 70 tonne
- RSS1344E** RSS1344E single reduction rear axle with differential lock - design GCW 44tonne
- RSS1352A** RSS1352A single reduction 13 tonne rear axle with differential lock - design GCW 52 tonne
- RSS1356** RSS1356 single reduction rear axle with differential lock - design GCW 56 tonne
- RSS1370A** RSS1370A single reduction 13 tonne rear axle with differential lock - design GCW 70 tonne
- RSS1370B** RSS1370B single reduction 13 tonne rear axle with differential lock - design GCW 70 tonne

PACKAGES

- AIRFLPAC** Air flow package including roof and side air deflectors plus

- Standard Equipment
- Optional Equipment

For more detailed information about cab and powertrain equipment, please refer to separate specification sheets.

For all possible options and combinations of options please consult your Volvo sales contact who can create a specification to match your requirements using the Volvo Sales Support system (VSS).

The factory reserves the right to modify design and change equipment without previous notification. The specification can vary from country to country.

chassis skirts

- DRIVEFM** Cab Package: Drive
- DRIVEFM+** Cab Package: Drive +
- BEDFM** One bed resting package
- AUDHIG** High Power Audio system: RDS radio with CD player - also playing MP3/WMA files from CD -, with integrated bluetooth phone and USB/Line inputs. FM/AM antenna, speakers in dashboard, doors, and sleeping compartment.
- MEDIA** AM/FM Bluetooth radio without CD player. USB and Aux line inputs. Speakers in dashboard, doors, and sleeping compartment. 7" touch screen with personal apps.
- MEDIADF** AM/FM Bluetooth radio without CD player. USB and Aux line inputs. Speakers in dashboard, doors, and sleeping compartment. 7" touch screen with personal and professional apps. Dynafleet vehicle on-board data display with office internet support.
- MEDIANAV** AM/FM Bluetooth radio without CD player. USB and Aux line inputs. Speakers in dashboard, doors, and sleeping compartment. 7" touch screen with personal and professional apps. Truck based satellite navigation (live updates not included)
- MEDIANDF** AM/FM Bluetooth radio without CD player. USB and Aux line inputs. Speakers in dashboard, doors, and sleeping compartment. 7" touch screen with personal and professional apps. Truck based satellite navigation (live updates not included) Dynafleet vehicle on-board data display with office internet support.
- VISIX15** Visibility Package
- ASAF15** Active Safety Package
- CHASSIS**
 - FST-AIR** Front suspension type - air
 - FST-PAR** Front suspension type - 2 leaf parabolic springs
 - FST-PAR3** Front suspension type - 3 leaf parabolic springs
 - FSLB-BAS** Front suspension levelling - basic stroke
 - FSLB-HI** Front suspension levelling - high stroke for demount operations - check with bodybuilder
 - FAL10.0** Front axle design capacity 10 tonnes - Ensure that you have checked the tyre load index
 - FAL7.1** Front axle design capacity 7.1 tonnes
 - FAL7.5** Front axle design capacity 7.5 tonnes
 - FAL8.0** Front axle design capacity 8.0 tonnes - Ensure that you have checked the tyre load index
 - FAL8.5** Front axle design capacity 8.5 tonnes
 - FAL9.0** Front axle design capacity 9.0 tonnes - Ensure that you have checked the tyre load index
 - FSM-LUB** Lubricated rear shackles on front suspension pins and bushings
 - FSTAB** Front anti-roll bar
 - FSTAB2** Front anti-roll bar medium stiffness
 - FSTAB3** Front stiff anti-roll bar
 - RAL11.7** Rear bogie design capacity 11.7 tonnes
 - RAL13** Rear axle design capacity 13 tonnes
 - RSTAB1** Rear anti-roll bar
 - RSTAB3** Rear stiff anti-roll bar
 - ASF-DL1** Air suspension with 1 driving level
 - ASF-DL3** Air suspension with 3 driving levels
 - ACTST-TO** Volvo Dynamic Steering (VDS) with with extra electronic pump and torque overlay
 - ASFE-BAS** Active steering feature - Basic - Volvo Dynamic Steering only
 - ASFE-OG** Active steering feature - Volvo Dynamic Steering with stability assist - oversteer
 - ASFE-PO** Active steering feature - Volvo Dynamic Steering with personal settings and stability assist

MODEL RANGE

FMX13 4x2 Tractor - Rear Air Suspension FM 42 T3HAX

- | | |
|---|--|
| <ul style="list-style-type: none"> <input type="checkbox"/> ASFE-PS Active steering feature - Volvo Dynamic Steering with personal settings <input checked="" type="checkbox"/> PSS-SING Single power steering system <input checked="" type="checkbox"/> PSP-FIX Power steering pump with fixed displacement <input type="checkbox"/> PSP-VAR Power steering pump with variable displacement <input checked="" type="checkbox"/> EBS-MED EBS medium package including "hill" hold function <input checked="" type="checkbox"/> AUXPARK Additional spring parking brakes <input checked="" type="checkbox"/> FBREG-E Front regulating brake valve, EBS <input checked="" type="checkbox"/> SUSPL-EC Remote electronic control on wander-lead for air suspension levelling <input checked="" type="checkbox"/> FRAME266 Frame rail section external height 266 mm <input type="checkbox"/> FRAME300 Frame rail section external height 300 mm <input type="checkbox"/> FST6060 Frame thickness - web and flange 6.0mm <input type="checkbox"/> FST6565 Frame thickness - web and flange 6.5mm <input checked="" type="checkbox"/> FST7070 Frame thickness - web and flange 7.0mm <input type="checkbox"/> FST8080 Frame thickness - web and flange 8.0mm <input type="checkbox"/> FIL-EEEB Inner liner from end of engine to end of bogie <input type="checkbox"/> FIL-TXEB Inner liner from gearbox member to end of bogie <input type="checkbox"/> BBOX-EF Battery box located in the end of frame <input checked="" type="checkbox"/> BBOX-L Battery box located on left hand side <input type="checkbox"/> BATS-D Dual energy battery system - 2 living batteries and 2 starter batteries. <input checked="" type="checkbox"/> BATS-S Single energy battery system (2 batteries) <input type="checkbox"/> 2BAT210B 2 x 210 Ah capacity Gel batteries <input checked="" type="checkbox"/> 2BATT170 2 x 170 Ah capacity batteries <input type="checkbox"/> 2BATT225 2 x 225 Ah capacity batteries <input checked="" type="checkbox"/> BATTAMP Battery voltage and ampere gauge <input type="checkbox"/> BATTIND Battery charge indication <input type="checkbox"/> ADR2 ADR package for transportation of dangerous goods on road (Note does NOT include safe loading pass package if required this is quoted separately) <input type="checkbox"/> MSWI-A Main switch - ADR switch circuit shut down <input checked="" type="checkbox"/> MSWI-C Main switch - Chassis mounted toggle switch by battery box <input type="checkbox"/> MSWI-R Main switch - Key fob operated remote controlled <input checked="" type="checkbox"/> R330A71 Right aluminium 710 mm D-shaped fuel tank, 330 litres volume
Min volume 255l
Max volume 810l <input checked="" type="checkbox"/> UL-FUEL Without left fuel tank
Min volume 160l
Max volume 900l <input type="checkbox"/> ADTP-BC AdBlue tank behind/under cab on right hand side <input type="checkbox"/> ADTP-L AdBlue tank on left hand side <input checked="" type="checkbox"/> ADTP-R AdBlue tank on right hand side <input type="checkbox"/> ADB048 AdBlue tank usable volume 48 litres <input type="checkbox"/> ADB050 AdBlue tank usable volume 50 litres - under cab <input checked="" type="checkbox"/> ADB064 AdBlue tank usable volume 64 litres <input type="checkbox"/> ADB068 AdBlue tank usable volume 68 litres <input type="checkbox"/> ADB090 AdBlue tank usable volume 90 litres <input type="checkbox"/> ADB100 AdBlue tank usable volume 100 litres <input type="checkbox"/> ADTC-BF AdBlue tank cover with satin alloy look decorative cover <input checked="" type="checkbox"/> FCAP-L Locking fuel filler cap <input checked="" type="checkbox"/> FUFF-AS Fuel filling anti-spillage device <input type="checkbox"/> FUFF-ATS Fuel filling anti-theft and anti-spillage devices <input type="checkbox"/> ESH-LEFT Horizontal silencer, left exhaust outlet <input checked="" type="checkbox"/> ESH-REAR Horizontal silencer, rear exhaust outlet <input type="checkbox"/> ESH-RIGH Horizontal silencer, right exhaust outlet <input type="checkbox"/> ESH-VERT Horizontal silencer, vertical exhaust outlet <input type="checkbox"/> EXST-SSP Stainless steel exhaust stack - NOT polished <input type="checkbox"/> WHC-FIX1 One fixed wheel chock <input type="checkbox"/> WHC-FIX2 Two fixed wheel chocks <input type="checkbox"/> WHC-FOL1 One foldable wheel chock | <ul style="list-style-type: none"> <input type="checkbox"/> WHC-FOL2 Two foldable wheel chocks <input type="checkbox"/> WHCP-F Wheel chock(s) stored in the front part of the vehicle <input type="checkbox"/> WHCP-M Wheel chock(s) stored in the middle part of the vehicle <input type="checkbox"/> WHCP-T Transport mounted wheel chock(s) stored in cab outer luggage locker <input type="checkbox"/> TB-L80 Toolbox 800 mm, left side <input type="checkbox"/> TB-R80 Toolbox 800 mm, right side <input type="checkbox"/> SUP-BAS EC approved chassis side guards <input type="checkbox"/> SUP-LOW EC approved low chassis side guards <input type="checkbox"/> CHAIN-S Snow chains <input type="checkbox"/> HOOK-SC Snow chain hooks <input checked="" type="checkbox"/> TOWF-HD1 One heavy duty front towing device <input checked="" type="checkbox"/> RFEC-B Rear frame end, bent down - standard for tractor vehicles <input type="checkbox"/> TOWR-ONE Towing hitch attached to rear crossmember <input type="checkbox"/> TREL15 Single 15 pole electrical trailer connector - ADR certified <input type="checkbox"/> TREL7 7 pole - 24N trailer electrical suzie <input checked="" type="checkbox"/> TREL7-7 24N and 24S trailer electrical suzies <input type="checkbox"/> TBC-DUO Duomatic type air line connectors <input type="checkbox"/> TBC-EC Palm coupling type air line connectors <input checked="" type="checkbox"/> TBC-GBR 'C' and 'CA' type air line connectors <input type="checkbox"/> TRBR-HCF Full pressure hand controlled trailer brake <input checked="" type="checkbox"/> TRBR-STA Stationary trailer brake control <input type="checkbox"/> TRB-STRE Stretch Brake - Automatic low speed trailer brake activation to avoid jack-knifing and improve steerability <input checked="" type="checkbox"/> RFEND-B Three piece EC approved rear mud wings and spray flaps <input checked="" type="checkbox"/> RFH-BAS Basic rear wing height <input type="checkbox"/> RFH-HIG High rear wing height - higher wing tops <input type="checkbox"/> RFH-LOW Lower rear wing height - shallower wing tops <input type="checkbox"/> ATANK-AL Aluminium air tanks <input checked="" type="checkbox"/> ATANK-ST Steel air tanks <input checked="" type="checkbox"/> TL-LED Rear lights LED <input type="checkbox"/> BLIGHT-E Emergency brake light <h3>WHEELS & TYRES</h3> <ul style="list-style-type: none"> <input type="checkbox"/> RT-AL Alcoa brushed aluminium rims with standard holes for long stud fixing on all axles <input type="checkbox"/> RT-ALDP Alcoa Dura-Bright EVO aluminium rims with standard holes long stud fixing on all axles, requires cleaning with a ph neutral solution - washing up liquid. <input type="checkbox"/> RT-ALDPD Alcoa Dura-Bright EVO aluminium rims with countersunk holes for short stud fixing on all axles, requires cleaning with a ph neutral solution - washing up liquid. <input type="checkbox"/> RT-ALDU Alcoa brushed aluminium rims with countersunk holes for short stud fixing on all axles <input checked="" type="checkbox"/> RT-STEEL Steel rims on all axles <input type="checkbox"/> WCAP Aerodynamic hub caps <input type="checkbox"/> BRREC002 Bridgestone Ecopia H 002 Evo - Tyre recommendation 2 <input type="checkbox"/> COREC001 Continental ECOPLUS HS3 XL/HD3 - Energy rating B or C depending on size <input type="checkbox"/> COREC002 Continental ECOPLUS HS3/HD3 - Energy rating B or C depending on size <input type="checkbox"/> COREC003 Continental Efficient Pro S/D - Fuel Tyre Recommendation 3 Reduced mileage compared to Conti EcoPlus long haul pattern please consider when selecting these tyres. <input type="checkbox"/> GYREC002 Goodyear FUELMAX S/D - Energy rating B or C depending on size <input type="checkbox"/> GYREC003 Goodyear FUELMAX S/(O)/D - Fuel tyre Recommendation 3 <input type="checkbox"/> GYREC004 Goodyear FUELMAX S - Energy rating B depending on size <input type="checkbox"/> HAREC001 Hankook AL10+ E-Cube Max Long Haul Tyre - Energy rating B <input type="checkbox"/> HAREC002 Hankook AL10+ E-Cube Long Haul Tyre - Energy rating B with wide single <input type="checkbox"/> MIREC001 Michelin XFA2/X-LINE Energy - Fuel tyre Recommendation 1 <input type="checkbox"/> MIREC002 Michelin XZA2/X-LINE Energy - Fuel tyre Recommendation 2 <input type="checkbox"/> MIREC003 Michelin X-LINE Energy - Fuel tyre Recommendation 3 |
|---|--|
- Standard Equipment Optional Equipment

For more detailed information about cab and powertrain equipment, please refer to separate specification sheets.

For all possible options and combinations of options please consult your Volvo sales contact who can create a specification to match your requirements using the Volvo Sales Support system (VSS).

The factory reserves the right to modify design and change equipment without previous notification. The specification can vary from country to country.

MODEL RANGE

FMX13 4x2 Tractor - Rear Air Suspension FM 42 T3HAX

- MIREC004** Michelin X Line Energy F/D2 - Energy rating A
 - PIREC001** Pirelli FH:01 Proway - Long Haul Tyre - Energy rating B
 - PIREC002** Pirelli FH:01 II Long Haul Tyre - Energy rating B with wide single
 - SPWT-D** Spare wheel & tyre with rear tyre pattern
 - SPWT-F** Spare wheel & tyre with front tyre pattern
 - SWCP-LF** Spare wheel carrier on left side of chassis ahead of rear axle
 - SWCP-RF** Spare wheel carrier on right side of chassis ahead of rear axle
 - SWCP-T** Spare wheel supplied temporarily strapped to chassis
 - SWCP-TP** Temporary spare wheel carrier on top of chassis frame
 - JACK-12T** 12 tonne bottle jack
 - JACK-15T** 15 tonne bottle jack
 - JACK-20T** 20 tonne bottle jack
 - TOOL-BAS** Basic Toolkit
 - TOOLKIT** Complete tool kit
 - INFLAHOS** Tyre inflation hose
 - GAUGE-TP** Tyre pressure gauge
- ### DRIVELINE EQUIPMENT
- TRAP-HD** Reinforced gearbox application
 - TP-CON** Construction Package
 - TP-DIST** Distribution Package
 - TP-LONG** Long Haul Package
 - AMSO-AUT** Enhanced I-shift software with manual shift available in auto mode and kickdown facility on accelerator pedal
 - AVO-ENH** Enhanced software for off road driveability and starting
 - APF-ENH** I-shift enhanced PTO functions
 - RET-TH** Gearbox mounted retarder
 - RET-TPT** Hydraulic Retarder for Powertronic gearbox
 - TC-HWO** Automatic gearbox oil cooler - water to oil
 - TC-MAOH2** Extra high performance transmission oil cooler - air to oil with front mounted radiator
 - TC-MWO** Basic transmission oil cooler - water to oil
 - 1COMP530** Single cylinder, air compressor, 530 litres per minute
 - 2COM1100** Two cylinder, air compressor, 1100 litres per minute
 - 2COMP900** Two cylinder, air compressor, 900 litres per minute
 - CLU-AIRC** Clutchable air compressor
 - AIRIN-HI** Roof mounted air intake behind cab on left hand side
 - AIRIN-LO** Low level air intake behind cab on left hand side
 - ACL1ST-S** Two stage air filter
 - 24AL110B** 110 amp alternator
 - 24AL120B** 120 amp alternator
 - 24AL150B** 150 amp alternator
 - CCV-C** Closed crankcase engine ventilation
 - CCV-O** Open crankcase engine breather
 - CCV-OX** Closed crankcase ventilation for cold markets
 - PRIM-EL** Electrical priming pump
 - PRIM-MAN** Manual priming pump
 - FUEQ-EH** Fuel line electric heater
 - AF-R** Hot fuel recirculation heated fuel filter
 - FUEFE2LW** Large engine mounted dual fuel filter with water separator
 - FUEFE2SW** Small engine mounted dual fuel filter with water separator
 - EST-AID** Air inlet manifold starting heater element
 - 220EBH15** 220V/1.5Kw electric engine block heater
 - PTER-100** Rear engine mounted power-take-off with DIN 100 / ISO 7646 flange
 - PTER-DIN** Rear engine mounted PTO with DIN5462 (female) splined shaft for a close coupled pump. Models with 3 steering axles will use this to drive the steering pump (AUXPSP)
 - PTER1400** Rear engine mounted power-take-off with SAE 1410 flange
 - HPE-F101** Parker F1-101, engine mounted, fixed displacement, single flow, engine mounted hydraulic pump
 - HPE-F41** Parker F1-41, engine mounted, fixed displacement, single flow, engine mounted hydraulic pump
 - HPE-F51** Parker F1-51, engine mounted, fixed displacement, single flow, engine mounted hydraulic pump
 - HPE-F61** Parker F1-61, engine mounted, fixed displacement, single flow, engine mounted hydraulic pump
 - HPE-F81** Parker F1-81, engine mounted, fixed displacement, single flow, engine mounted hydraulic pump
 - HPE-T53** Parker F2-53/53, engine mounted, Fixed displacement, Twin flow engine mounted hydraulic pump
 - HPE-T70** Parker F2-70/35, engine mounted, Fixed displacement, Twin flow engine mounted hydraulic pump
 - HPE-V45** Parker VP1-45, variable displacement, single flow, engine mounted hydraulic pump
 - HPE-V75** Parker VP1-75, variable displacement, single flow, engine mounted hydraulic pump
 - PTPT-D** Powertronic PTO, 1 front/upper DIN connection for plug-in pump (max. 850 Nm)
 - PTPT-F** Powertronic PTO, 1 front/upper rear facing SAE flange conn. for prop shaft (max.850 Nm)
 - PTR-D** Gearbox PTO for plug-in pump, 0.71xeng speed
 - PTR-DH** Gearbox driven high speed PTO for one plug-in hydraulic pump
 - PTR-DM** Gearbox driven medium speed PTO for one plug-in hydraulic pump
 - PTR-F** Gearbox driven PTO with rear flange connection
 - PTR-FH** Gearbox driven high speed PTO with SAE drive flange
 - PTR-FL** Gearbox driven low speed PTO with SAE drive flange
 - PTRD-D** Gearbox driven HIGH SPEED PTO for two plug-in hydraulic pumps
 - PTRD-D1** PTRD-D1 Gearbox driven HIGH SPEED PTO (1 SAE flange & 1 plug-in hydraulic pump)
 - PTRD-D2** Gearbox driven HIGH SPEED PTO (2 SAE flanges & 1 plug-in hyd pump)
 - PTRD-F** PTO with 1 DIN + 1 flange connection rear, manual gearbox
 - HPG-F101** Parker F1-101 gearbox mounted, fixed displacement, single flow, hydraulic pump
 - HPG-F41** Parker F1-41 gearbox mounted, fixed displacement, single flow, hydraulic pump
 - HPG-F51** Parker F1-51 gearbox mounted, fixed displacement, single flow, hydraulic pump
 - HPG-F61** Parker F1-61 gearbox mounted, fixed displacement, single flow, hydraulic pump
 - HPG-F81** Parker F1-81 gearbox mounted, fixed displacement, single flow, hydraulic pump
 - EIDLES D** Engine idle shut down
 - STWPOS-R** RIGHT HAND DRIVE
 - STWM-LE** Leather steering wheel
 - STGW-AD2** Adjustable steering wheel with neck tilt
 - STGW-ADJ** Adjustable steering wheel
 - AIRBAG** SRS Driver's air bag
 - DRC-AMII** DPF Regeneration control switch - for manual and switching off regeneration
 - 1DAYDIG2** Continental VDO DTCO 4.0 smart tachograph
This tachograph can ONLY offer remote download if the option of Dynafleet or an FMS gateway has been specified with this order.
 - 1DAYDIGP** Continental VDO DTCO 3.0 digital tachograph
For vehicles with long lead time - this includes prep kit for the retrofit of DTCO 4.0 tachograph.
For updating to new legal demand for trick registration from 15th June 2019.
This tachograph can ONLY offer remote download if the option of Dynafleet or an FMS gateway has been specified with this order.
- Standard Equipment Optional Equipment

For more detailed information about cab and powertrain equipment, please refer to separate specification sheets.

For all possible options and combinations of options please consult your Volvo sales contact who can create a specification to match your requirements using the Volvo Sales Support system (VSS).

The factory reserves the right to modify design and change equipment without previous notification. The specification can vary from country to country.

MODEL RANGE

FMX13 4x2 Tractor - Rear Air Suspension FM 42 T3HAX

<input type="checkbox"/> ARSL	Additional road speed limit - switch in dashboard	<input checked="" type="checkbox"/> UPHTRI11	Seats: Light grey embossed textile insert, black raven metallic vinyl bolster with red vinyl side insert. Interior trim: Raven black bunk and curtains & grey vinyl side walls
<input type="checkbox"/> CRUIS-E	Eco cruise control (with eco-roll and l-cruise, controls in steering wheel)	<input type="checkbox"/> UPHTRI12	Seats: Blue soft textile insert, black vinyl bolster. Interior trim: Raven black bunk and curtains & blue textile side walls
<input checked="" type="checkbox"/> CRUISEC	Cruise control, standard	<input type="checkbox"/> UPHTRI13	Seats: Dark grey leather insert and black leather bolster. Interior trim: Raven black bunk and curtains & grey vinyl side walls
<input checked="" type="checkbox"/> ESP-BAS1	Electronic Stability Control	<input type="checkbox"/> UPHTRI14	Seat: Dark grey leather insert and black leather bolster. Interior trim: Raven black bunk and curtains & blue textile side walls
<input type="checkbox"/> ESPC-RO	ESP (Electronic Stability Program) functionality control - Reduced / Off	<input checked="" type="checkbox"/> DST-CF4	Driver seat, comfort, suspended, belt in seat
<input type="checkbox"/> HWSS-ACB	Adaptive cruise control ACC with forward collision warning and AEBs advanced emergency brake system	<input type="checkbox"/> DST-CF5	Driver seat, comfort, suspended, belt in seat, electrically heated
<input checked="" type="checkbox"/> HWSS-FCB	Forward collision warning with AEBs advanced emergency brake system	<input type="checkbox"/> DST-CF6	Driver seat, comfort, suspended, belt in seat, electrically heated, ventilated
<input checked="" type="checkbox"/> LSS-DW	Lane departure-warning system	<input type="checkbox"/> SBD-RED	Red seat belts
<input type="checkbox"/> LCS	Lane change support	<input type="checkbox"/> SBPRE-DS	Driver seat belt pretensioner
<input type="checkbox"/> DAS-W	Driver Alert Support system	<input checked="" type="checkbox"/> PST-BAS1	Passenger seat - Fixed non suspended fold up with seatbelt mounted in cab
<input type="checkbox"/> RSENS-W	Rain sensing windscreen wipers	<input type="checkbox"/> PST-BENC	Bench passenger seat
<input type="checkbox"/> CU-ECC	Electrically controlled air conditioning with sun sensor	<input type="checkbox"/> PST-CF4	Passenger seat - Comfort suspended with seatbelt mounted in seat
<input type="checkbox"/> CU-ECC2	Electrically controlled air conditioning with sun sensor, mist sensor, air quality sensor and carbon filter	<input type="checkbox"/> PST-CF5	Passenger seat - Comfort suspended & heated with seatbelt mounted in seat
<input checked="" type="checkbox"/> CU-MCC	Climate unit with manual controlled air conditioning	<input type="checkbox"/> PST-STD2	Passenger seat - Fixed non suspended with seatbelt mounted in cab
<input checked="" type="checkbox"/> IMMOBIL	Thatcham H2 approved immobiliser	<input type="checkbox"/> PST-STD4	Passenger seat - Standard suspended with seatbelt mounted in cab
<input type="checkbox"/> ALARM-B	Thatcham H1 approved vehicle alarm - Cab only	<input type="checkbox"/> SBPRE-PS	Passenger seat belt pretensioner
<input type="checkbox"/> ALARM-E	Enhanced vehicle alarm - Thatcham H1 approved - Cab plus external sensor for body/trailer	<input type="checkbox"/> ARM-DBPS	Two armrests on driver seat and one (outer) on passenger seat
<input type="checkbox"/> ALCOLOCK	Alcolock	<input type="checkbox"/> ARMRE-BB	Two armrests on both driver and passenger seat.
<input type="checkbox"/> BUPMON	Back up monitor with built in 7" screen on dash and one colour camera supplied loose for fitment by bodybuilder. Can accommodate up to 4 cameras for TfL Safe Scheme, CLOCS and FORS.	<input type="checkbox"/> ARMRE-DB	Two armrests, on driver seat only
<input type="checkbox"/> PHONE-PK	Telephone preparation kit (antenna, antenna attachm. cable incl.)	<input type="checkbox"/> ARMRE-PB	Two armrests, on passenger seat only
<input type="checkbox"/> WLIFT-AD	Electrical window lift, automatic up/down driver side	<input type="checkbox"/> ARMRE-PS	Single armrest (next to driver) on passenger seat
<input checked="" type="checkbox"/> WLIFT-EB	Electrical window lift	<input type="checkbox"/> ARU-BAS	Vinyl upholstered armrest
<input type="checkbox"/> WLIFT-ME	Mechanical window lift	<input type="checkbox"/> ARU-LEA	Leather upholstered armrest
<input type="checkbox"/> ISUNS-BS	Side interior sun visor on both sides	<input checked="" type="checkbox"/> FMAT-RU2	Rubber floor mats, extended
<input checked="" type="checkbox"/> ISUNS-DS	Driver's side interior sun visor	<input type="checkbox"/> FMAT-RUB	Rubber floor mats
<input checked="" type="checkbox"/> ISUNF-B	Interior front sun visor without mirror	<input type="checkbox"/> FMAT-T2E	Textile and rubber floor mats
<input type="checkbox"/> ISUNF-MD	Interior front sun visor with mirror on driver side	<input type="checkbox"/> FMAT-TX2	Textile and rubber floor mats
<input type="checkbox"/> ISUNF-RE	Electrically operated textile interior sun blind	<input type="checkbox"/> LBK-RES	Foldable rest bunk
<input type="checkbox"/> ISUNF-RM	Manually operated textile interior sun blind	<input checked="" type="checkbox"/> LBK70	Lower bunk 700 x2000 mm, fixed
<input type="checkbox"/> ADFS	Two extra DIN slots in front shelf - can be fitted with card or drawer available as an accessory	<input type="checkbox"/> ULBK	Without lower bunk
<input checked="" type="checkbox"/> BUPALARM	Reverse alarm	<input type="checkbox"/> MATL-FI	Firm lower bunk pocket sprung mattress
<input type="checkbox"/> RTOLL-PK	Road toll PREPARATION kit for trucks operating with "Toll Collect" in Germany	<input checked="" type="checkbox"/> MATL-SF	Lower flexizone mattress - semi-firm, pocket springs up to 100kg - 16 stone
<input type="checkbox"/> LOADIND	Load indicator with central dashboard display	<input type="checkbox"/> MATL-SO	Lower flexizone mattress - soft, pocket springs up to 85kg - 13.5 stone
<input type="checkbox"/> REMC-MF	Multi-functio wireless remote control	<input type="checkbox"/> OLMAT-BA	35mm mattress overlay protector
<input type="checkbox"/> FIREXT3S	3kg fire extinguisher mounted on seat base	<input type="checkbox"/> OLMAT-PR	50mm premium mattress overlay protector
<input type="checkbox"/> WARNVEST	High visibility warning vest - no sleeves	<input type="checkbox"/> TBK60F	Fixed foldable top bunk 600 x 1900mm
<input type="checkbox"/> AIDKIT	First aid kit	<input type="checkbox"/> TBK70F	Fixed foldable top bunk 700 x 1900mm
<input type="checkbox"/> AIDKIT1B	First aid kit	<input type="checkbox"/> PH-CAB2	1.8kW Air to air night heater
<input type="checkbox"/> WARNLAMP	Portable warning lamp	<input type="checkbox"/> PH-ENGCA	Engine and cab night heater
<input type="checkbox"/> LAMP-IN	Inspection lamp	<input type="checkbox"/> PH-SS	Short stop heater
<input type="checkbox"/> BULBKIT	Bulb and fuse kit	<input type="checkbox"/> SLCP-BAS	Basic sleeper control panel - includes interior light, parking heater, roof hatch and door lock
<input type="checkbox"/> WRITEPAD	Writing pad	<input type="checkbox"/> SAFE	Safe box for driver's personal items
<input type="checkbox"/> UPHTRI10	Seats: Black embossed textile insert with light grey sides, black vinyl side bolster with blue vinyl side insert. Interior trim: Raven black bunk and curtains & blue textile side walls	<input type="checkbox"/> ETSB-F	Storage on engine tunnel - on front top
		<input type="checkbox"/> ETSB-FR	Storage on engine tunnel - on front top and at rear cab wall
		<input type="checkbox"/> ETSB-FRS	Storage on engine tunnel - on front top & at rear cab wall & storage recessed into tunnel on right hand side

Standard Equipment

Optional Equipment

For more detailed information about cab and powertrain equipment, please refer to separate specification sheets.

For all possible options and combinations of options please consult your Volvo sales contact who can create a specification to match your requirements using the Volvo Sales Support system (VSS).

The factory reserves the right to modify design and change equipment without previous notification.
The specification can vary from country to country.

MODEL RANGE

FMX13 4x2 Tractor - Rear Air Suspension FM 42 T3HAX

- ETSB-FS** Storage on engine tunnel - on front top and storage recessed into tunnel on right hand side
 - ETSB-R** Storage on engine tunnel - box at rear cab wall
 - ETSB-RS** Storage on engine tunnel - at rear cab wall and storage recessed into tunnel on right hand side
 - ETSB-S** Storage on engine tunnel - recessed into tunnel on right hand side
 - RUS-BAS** Rear cab upper storage 154 litres - 300 mm high
 - RUS-HIG** Rear cab upper storage 245 litres - 440 mm high
 - TABLE** Folding and height adjustable table - on lower bunk
 - REF-ICPK** Fridge: engine tunnel mounted preparation kit
 - REFR-RUS** Fridge: 28 litre rear upper wall mounted with dividers
 - MICRO-PK** Preparation kit for microwave oven (wiring)
 - BOTH-D** One bottle holder under dashboard centre section
 - COFMA-PK** Coffee maker, preparation kit.
 - INLI-BAS** Interior white LED lights - basic
 - INLI-NL** Interior white and red night LED light with no dimmer
 - INLI-NLD** Interior white and red night LED light with dimmer
 - ARL-FLEX** Two flexible reading lamps (snake lamps)
 - RH-EE** Without roof hatch -Tinted glass emergency exit ONLY
 - RH-ETR** Glass roof & escape hatch - Electrically operated, tinted glass with rear opening
 - RH-MSR** Steel roof & escape hatch - Manually operated with rear opening
 - RH-MTR** Glass roof & escape hatch - Manually operated, tinted glass with rear opening
 - URH** Without roof hatch
 - SWIND-BS** Extra side window on both sides behind "B" pillar
 - SWIND-PS** Rear side window, passenger side
 - VANMIR** Vanity mirror in front shelf
 - AS-FUS** Extra shelf in front upper storage compartments
 - INFOT-PK** Preparation kit for the mounting of a flat screen TV in cab above the driver's door, includes bracket, electrical and speaker connections
- CAB EXTERIOR**
- PAICS-B** Basic cab paint - mirrors, sunvisor, instep and bumper supplied in natural finish - grey
 - GLAS-TIN** Tinted windows.
 - AWIND-RF** Rear window
 - DGLAS-L** Laminated door glass
 - LOCK-MAN** Manual door locking
 - LOCK-MRP** Manual door locking with internal remote control (from driver side) of passenger door
 - LOCK-REM** Central locking with remote control
 - BUMP-HD** Heavy duty front bumper
 - GUARD-EH** Engine guard to protect sump and engine hoses
 - BUGNET** Insect screen in front of radiator
 - CTILT-P-E** Electrically operated hydraulic cab tilt
 - CTILT-P-M** Manually operated hydraulic cab tilt
 - FCABS-A** Front cab suspension - Air
 - FCABS-M** Front cab suspension - Mechanical spring
 - RCABS-A** Rear cab suspension - Air
 - RCABS-M** Rear cab suspension - Mechanical spring
 - MIRCOMFX** Electrically heated and operated -FMX- main and wide-angle mirrors with manually adjusted passenger kerb mirror, to increase direct vision to the side the main mirrors have no cowlings
 - MIRSTDX** Electrically heated -FMX- main and wide-angle mirrors with manually adjusted passenger kerb mirror, to increase direct vision to the side the main mirrors have no cowlings
- AMIR-F20** Auxiliary front view mirror with a 200mm radius
 - SUNV-H** External smoke grey sunvisor
 - AD-ROOF** Roof air deflector
 - AD-SIDEL** Side air deflector extension panels
 - AD-SIDES** Short cab side air deflector for rigid bodywork
 - AD-CHASX** Chassis side skirts
 - ADCF-F** Additional black edging on chassis side skirt
 - HL-BAS2** Halogen H1 head lamps
 - HL-BASIC** Halogen H7 head lamps
 - HL-BHID2** Dynamic high intensity Bi-Xenon head lamps
These follow the steering movement and direction of the truck
 - HL-CLEAN** Head lamp cleaner - washer jets
 - HLP-ST** Headlamp protection
 - HL-ADJ** Headlight adjustment - Switch in cab
 - ASL-RF2** Two Hella H11 70W spotlamps in sign box - only available with the basic headlight and no lower driving lights.
Preparation kit for two spotlamps in sign box
 - ASL-RFPK** Preparation kit for two spotlamps in sign box
 - BEACOA2F** Two front roof mounted amber beacon rotating warning lamps
 - BEACOA2R** Two rear roof mounted (on accessory bracket) amber beacon flashing warning LED lamps
 - BEACON-P** Roof beacon wire preparation
 - BEACONA4** Four roof mounted (2 front/2 rear) amber beacon rotating warning lamps
 - CABPT-R1** Single outlet for roof mounted accessories
 - CABPT-R2** Twin outlets for roof mounted accessories.
 - SPOTP-F** Spotlamp preparation in front, max 280W
 - SPOTP-R** Spotlamp preparation on roof, max 280W
 - SPOTP-RF** Spotlamp preparation on cab roof and in cab front, max 2x280W
 - ROS-IL2** Preparation kit for illuminated roof sign with switch loose in cab, fit after registration
 - CSGN-FMX** "Volvo FMX" headboard logo
 - HORN-F1S** Single tone Jericho air horn chassis mounted
 - HORN-R2S** Two roof mounted air horns
 - ANT-CBR** Roof mounted antenna for CB radio, single aerial
 - ACCB-R-AP** Front, middle & rear roof mounted accessory brackets
 - ACCB-R-F** Front roof mounted accessory bracket
 - ACCB-R-FM** Front & middle roof mounted accessory brackets
 - ACCB-R-FR** Front & rear roof mounted accessory brackets
 - ACCB-R-M** Middle roof mounted accessory bracket
 - ACCB-R-R** Rear roof mounted accessory bracket
 - ACCB-R-RM** Rear & middle roof mounted accessory brackets
 - RFCAR-BC** Rear mudwing carrier, back of cab
 - LADDER** Ladder back of cab
 - REFS-TW** White cab conspicuity markings by packed in cab
 - REFS-TY** Yellow cab conspicuity markings by packed in cab
- SUPERSTRUCTURE PREPARATIONS**
- 5WM-ASL** 4mm high 'L' profiles for air actuated sliding 5th wheel
 - 5WM-ASM** 50mm high 'L' profiles for air actuated sliding 5th wheel
 - 5WM-ISOL** 5th wheel subframe 16mm high above chassis frame
 - 5WM-ISOM** 5th wheel subframe 60mm high above chassis frame
L profiles 50mm with 10mm thick plate
 - 5WM-LPRO** 5th wheel attached direct to frame with inverted 'L'-profiles
 - 5WM-MASL** 4mm high 'L' profiles for manual sliding fifth wheel
 - 5WM-MASM** 50mm high 'L' profiles for manual sliding fifth wheel
 - 5WH140** Fifth wheel leg-height 140 mm
 - 5WH150** Fifth wheel leg-height 150 mm
 - 5WH160** Fifth wheel leg-height 160 mm
 - 5WH175** Fifth wheel leg height 175mm
 - 5WH185** Fifth wheel leg-height 185 mm
 - 5WH195** Fifth wheel leg-height 195mm

Standard Equipment Optional Equipment

For more detailed information about cab and powertrain equipment, please refer to separate specification sheets.

For all possible options and combinations of options please consult your Volvo sales contact who can create a specification to match your requirements using the Volvo Sales Support system (VSS).

The factory reserves the right to modify design and change equipment without previous notification. The specification can vary from country to country.

MODEL RANGE

FMX13 4x2 Tractor - Rear Air Suspension FM 42 T3HAX

- 5WH200** Fifth wheel leg-height 200 mm
- 5WH205** Fifth wheel leg-height 205 mm
- 5WH210** Fifth wheel leg-height 210 mm
- 5WH220** Fifth wheel leg-height 220mm
- 5WH230** Fifth wheel leg-height 230 mm

- **5WT-FO14** Fontaine 150SP2 pressed steel fifth wheel
- 5WT-FO15** Fontaine 3000 lightweight cast fifth wheel with 150SF air operated slider - for moderate duty off road. Specified fifth wheel position always gives rearmost position.

- 5WT-JO10** Jost JSK 36 pressed fifth wheel
- 5WT-JO8** Jost JSK 37 cast fifth wheel
- 5WT-JO9** Jost JSK 42 cast fixed fifth wheel
- 5WT-SH** SAF-Holland/+GF+ SK-S 36.20 cast fixed fifth wheel

- **5WLM-B** Basic fifth wheel maintenance standard top plate
- 5WLM-L** Low maintenance fifthwheel with nylon top plate

- 5WL-S1** Fifth wheel lubrication - locking mechanism and top plate
- 5WL-S2** Fifth wheel lubrication - locking mechanism

- TCIND** Trailer connection indication with sensors for height, kingpin and coupling lock

- **RDECK** Catwalk & step
- RDECK-M** Rear catwalk 760mm

- SRWL-PK** Wiring preparation for side & rear work/reverse lamps on side of chassis and a three-position switch, maximum 280W
- SWL-2RA** Two H3 35W amber rear chassis mounted (LH/RH side) working lamps and a 2-position switch (On/Off)
- SWL-2RW** Two H3 70W white rear chassis mounted (LH/RH side) working lamps and a 2-position switch (On/Off)
- SWL-PK** Wiring preparation for side work/reverse lamps on side of chassis and a three-position switch, maximum 280W

- **WL-TA1W** White coupling light
- WLC-H2A** Two H3/70W working lamps with amber coloured lens high mounted back of cab
- WLC-H2W** Two H3/70W white working lamps high mounted on the back of cab
- WLC-PKH** Preparation kit, cables and switch for high mounted working lamps back of cab
- WLC-PKL** Preparation kit, cables and switch for low mounted working lamps back of cab
- WLC-PKLH** Preparation kit - cables and switch for low and high mounted working lamps back of cab.

- **ECBB-BAS** Body builder electrical centre without body builder module
- ECBB-HIG** Body builder electrical centre with body builder module

- BBCHAS1** One 7-pole connector for Body builder interface
- BBCHAS3** Three 7-pole connectors for Body builder interface

- BEPR-T2** Body builder electrical software preparation for tipper with remote control

- EXSTER** External steering control, with VDS and bodybuilder module
- TD-BAS** Trailer detection WITHOUT LED sensing
- **TD-LED** Trailer detection with LED sensing

- AUXL-SPK** Electrical preparation kit - wiring and switch for snow plough lights

- TAILPRE2** Tail lift preparation kit, wireless remote operation
- TAILPREP** Taillift preparation kit - cab switch and warning in driver display

- AESW2** Two Body builder bistable electrical switches (marked AUX1 / AUX2)
- AESW2PK** 2 Body builder bistable el.switches (marked AUX1/AUX2) and prep. for 4 more switches

- AUXSW-4** Wiring for 4 extra switches (from Body builder electrical centre to switch positions)

DELIVERY SERVICES

- **TGW-4GWL** GSM/GPRS/4G modem, LTE & WLAN for telematics gateway
- FMS-PK** Fleet Management System gateway

VOLVO

Volvo Truck Corporation

volvotrucks.com