

# MODEL RANGE

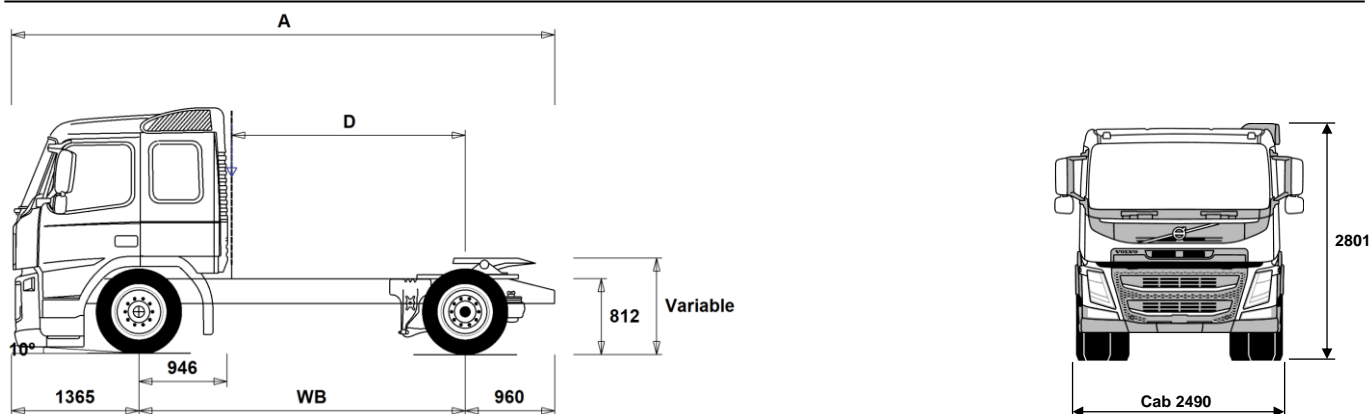

Volvo Trucks. Driving Progress

FM 11 4x2 Tractor - X-Low - Full Air Suspension FM 42 T1XA



## Chassis Dimensions [mm]

WB Wheelbase	3500	3600	3800
A Overall Chassis Length	5825	5925	6125
D Center of rear axle to back of cab	2504	2604	2804
F Fifth Wheel Position (EC Directive 96/53)	375	375	375

## Chassis Weights [kg]

Front Axle	4285	4280	4285
Rear Axle	1820	1820	1840
Kerb Weight	6105	6100	6125

## Turning Diameter [mm]

Turning Circle Diameter Kerb to Kerb	12700	13000	13600
Turning Circle Diameter Wall to Wall	14200	14500	15100

## Plated Weights [kg]

	Plated	Design
Gross Vehicle Weight	18000	18600
Gross Combination Weight	40000	44000
Front Axle	6700	7100
Rear Axle	11500	11500

## Important Notes

### Chassis Dimensions

Cab Height: +416 mm for CAB-HSLP, -169 mm for CAB-LSLP, +554 mm for CAB-XHSL.

Front Axle to Back of Cab: -424 mm for CAB-DAY, -6 mm for CAB-LSLP.

D-measure includes a front clearance of 50 mm and for rigid trucks also a subframe of 100 mm.

Height can vary  $\pm 20$  mm for leaf and  $\pm 10$  mm for air suspension.

All dimensions are for unladen chassis and any tag axles down.

Weight and dimensions are based upon the following tyres:

Front Axle Tyres: 295/60R22.5

Drive Axle Tyres: 295/60R22.5

**Chassis weight includes oil, water, AdBlue, 0 litres fuel and without driver. Kerb weight can vary  $\pm 3\%$ .**

Turning diameters are theoretically calculated.

Legal weights can differ from country to country.

For more detailed weight information, including optional equipment weights, ask your Volvo sales contact to enter your specification into the Volvo Weight Information system (WIS).

Do NOT use this drawing for bodybuilding. Refer to Volvo Bodybuilder Instructions and chassis assembly drawing FM42T1XA.

# MODEL RANGE

FM 11 4x2 Tractor - X-Low - Full Air Suspension FM 42 T1XA

## TRUCK USE

- **RC-SMOOT** Operating class highway

## CORE COMPONENTS

- **CHH-XLOW** Chassis frame height extra low - For a specific loading height always check the unique BEP chassis drawing
- **RAD-G4** RAD-G4 - 4x2 Air - Lite
- **RAD-GR** RAD-GR- 4x2 Air - High
- **FM-DAY** Day cab - with steel safety cage design  
Designed and built to Swedish impact and ECE R29 regulations
- **FM-HSLP** Globetrotter cab - with steel safety cage design  
Designed and built to Swedish impact and ECE R29 regulations
- **FM-LSLP** Low sleeper cab - with steel safety cage design  
Designed and built to Swedish impact and ECE R29 regulations
- **FM-SLP** Sleeper cab - with steel safety cage design  
Designed and built to Swedish impact and ECE R29 regulations
- **FM-XHSL** Globetrotter LXL cab - with steel safety cage design  
Designed and built to Swedish impact and ECE R29 regulations
- **EU6SCR** Emission level - Euro 6
- **D11K330** D11K330 10.8 litre engine developing 330hp at 16-1900rpm.  
Peak torque 1600Nm at 950-1400rpm.
- **D11K380** D11K380 10.8 litre engine developing 380hp at 17-1900rpm.  
Peak torque 1800Nm at 950-1400rpm.
- **D11K430** D11K430 10.8 litre engine developing 430hp at 17-1800rpm.  
Peak torque 2050Nm at 1058-1400rpm.
- **D11K460** D11K460 10.8 litre engine developing 450hp at 16-1800rpm.  
Peak torque 2200Nm at 1050-1400rpm.
- **EBR-EPG** Exhaust brake controlled by steering column switch
- **EBR-EPGC** Exhaust pressure governor for I shift gearbox
- **EBR-VEB** Volvo engine brake and exhaust pressure governor retardation 300kW
- **AT2412F** AT2412F 12-speed "I-shift" automated mechanical gearbox suitable for gross train weights up to 44tonne only refer to sales engineering when used in conjunction with a PTO
- **AT2612F** AT2612F 12-speed "I-shift" automated mechanical gearbox suitable for gross train weights up to 60tonne only refer to sales engineering when used in conjunction with a PTO
- **ATO2612F** ATO2612F 12-speed "I-shift" overdrive automated mechanical gearbox suitable for gross train weights up to 60tonne refer to sales engineering when used in conjunction with a PTO
- **RSS1344E** RSS1344E single reduction rear axle with differential lock - design GCW 44tonne
- **RSS1352A** RSS1352A single reduction 13 tonne rear axle with differential lock - design GCW 52 tonne
- **RSS1356** RSS1356 single reduction rear axle with differential lock - design GCW 56 tonne

## PACKAGES

- **LHFP-VE** Long Haul Fuel Economy driving package
- **DRIVEFM** Cab Package: Drive
- **DRIVEFM+** Cab Package: Drive +
- **BEDFM** One bed resting package
- **AUDHIG** High Power Audio system: RDS radio with CD player - also playing MP3/WMA files from CD -, with integrated bluetooth phone and USB/Line inputs. FM/AM antenna, speakers in dashboard, doors, and sleeping compartment.
- **MEDIA** AM/FM Bluetooth radio without CD player.  
USB and Aux line inputs.  
Speakers in dashboard, doors, and sleeping compartment.  
7" touch screen with personal apps.

■ Standard Equipment

□ Optional Equipment

For more detailed information about cab and powertrain equipment, please refer to separate specification sheets.

For all possible options and combinations of options please consult your Volvo sales contact who can create a specification to match your requirements using the Volvo Sales Support system (VSS).

The factory reserves the right to modify design and change equipment without previous notification. The specification can vary from country to country.

- **MEDIADF** AM/FM Bluetooth radio without CD player.  
USB and Aux line inputs.  
Speakers in dashboard, doors, and sleeping compartment.  
7" touch screen with personal and professional apps.  
Dynafleet vehicle on-board data display with office internet support.
- **MEDIANAV** AM/FM Bluetooth radio without CD player.  
USB and Aux line inputs.  
Speakers in dashboard, doors, and sleeping compartment.  
7" touch screen with personal and professional apps.  
Truck based satellite navigation (live updates not included)
- **MEDIANDF** AM/FM Bluetooth radio without CD player.  
USB and Aux line inputs.  
Speakers in dashboard, doors, and sleeping compartment.  
7" touch screen with personal and professional apps.  
Truck based satellite navigation (live updates not included)  
Dynafleet vehicle on-board data display with office internet support.

- **VISI15** Visibility Package
- **VISI15+** Visibility Plus Package

- **ASAF15** Active Safety Package

## CHASSIS

- **FST-AIR** Front suspension type - air
- **FAL7.1** Front axle design capacity 7.1 tonnes
- **FAL7.5** Front axle design capacity 7.5 tonnes
- **FSTAB** Front anti-roll bar
- **RAL11.5** Rear axle design capacity 11.5 tonnes
- **RSTAB1** Rear anti-roll bar
- **RSTAB3** Rear stiff anti-roll bar
- **ASF-DL1** Air suspension with 1 driving level
- **ASF-DL3** Air suspension with 3 driving levels
- **ACTST-T0** Volvo Dynamic Steering (VDS) with with extra electronic pump and torque overlay
- **ASFE-BAS** Active steering feature - Basic - Volvo Dynamic Steering only
- **ASFE-OG** Active steering feature - Volvo Dynamic Steering with stability assist - oversteer
- **ASFE-PO** Active steering feature - Volvo Dynamic Steering with personal settings and stability assist
- **ASFE-PS** Active steering feature - Volvo Dynamic Steering with personal settings
- **PSS-SING** Single power steering system
- **PSP-FIX** Power steering pump with fixed displacement
- **PSP-VAR** Power steering pump with variable displacement
- **EBS-MED** EBS medium package including "hill" hold function
- **AUXPARK** Additional spring parking brakes
- **FRAME266** Frame rail section external height 266 mm
- **FST7070** Frame thickness - web and flange 7.0mm
- **FST8080** Frame thickness - web and flange 8.0mm
- **BBOX-L** Battery box located on left hand side
- **2BAT210B** 2 x 210 Ah capacity Gel batteries
- **2BATT170** 2 x 170 Ah capacity batteries
- **2BATT225** 2 x 225 Ah capacity batteries
- **BATTAMP** Battery voltage and ampere gauge
- **BATTIND** Battery charge indication
- **ADR2** ADR package for transportation of dangerous goods on road (Note does NOT include safe loading pass package if required this is quoted seperately)
- **MSWI-A** Main switch - ADR switch circuit shut down
- **MSWI-C** Main switch - Chassis mounted toggle switch by battery box
- **MSWI-R** Main switch - Key fob operated remote controlled
- **R315A56** Right aluminium 560 mm D-shaped fuel tank, 315 litres volume  
Min volume 255l

# MODEL RANGE

FM 11 4x2 Tractor - X-Low - Full Air Suspension FM 42 T1XA

- Max volume 630l
- **UL-FUEL** Without left fuel tank  
Min volume 160l  
Max volume 505l
- **ADTP-BC** AdBlue tank behind/under cab on right hand side
- **ADTP-L** AdBlue tank on left hand side
- **ADTP-R** AdBlue tank on right hand side
- **ADB048** AdBlue tank usable volume 48 litres
- **ADB050** AdBlue tank usable volume 50 litres - under cab
- **ADB068** AdBlue tank usable volume 68 litres
- **ADTC-BF** AdBlue tank cover with satin alloy look decorative cover
- **FCAP-L** Locking fuel filler cap
- **FUFF-AS** Fuel filling anti-spillage device
- **FUFF-ATS** Fuel filling anti-theft and anti-spillage devices
- **ESH-LEFT** Horizontal silencer, left exhaust outlet
- **ESH-REAR** Horizontal silencer, rear exhaust outlet
- **ESH-VERT** Horizontal silencer, vertical exhaust outlet
- **EXST-SSP** Stainless steel exhaust stack - NOT polished
- **WHC-FIX1** One fixed wheel chock
- **WHC-FIX2** Two fixed wheel chocks
- **WHC-FOL1** One foldable wheel chock
- **WHC-FOL2** Two foldable wheel chocks
- **WHCP-F** Wheel chock(s) stored in the front part of the vehicle
- **WHCP-M** Wheel chock(s) stored in the middle part of the vehicle
- **WHCP-T** Transport mounted wheel chock(s) stored in cab outer luggage locker
- **CHAIN-S** Snow chains
- **TOWF-NO1** One front towing device
- **TOWF-NO2** Two front towing devices
- **RFEC-B** Rear frame end, bent down - standard for tractor vehicles
- **TREL15** Single 15 pole electrical trailer connector - ADR certified
- **TREL7** 7 pole - 24N trailer electrical size
- **TREL7-7** 24N and 24S trailer electrical sizes
- **TBC-DUO** Duomatic type air line connectors
- **TBC-EC** Palm coupling type air line connectors
- **TBC-GBR** 'C' and 'CA' type air line connectors
- **TRBR-HCF** Full pressure hand controlled trailer brake
- **TRBR-STA** Stationary trailer brake control
- **TRB-STRE** Stretch Brake - Automatic low speed trailer brake activation to avoid jack-knifing and improve steerability
- **RFEND-B** Three piece EC approved rear mud wings and spray flaps
- **RFH-BAS** Basic rear wing height
- **RFH-HIG** High rear wing height - higher wing tops
- **RFH-LOW** Lower rear wing height - shallower wing tops
- **ATANK-AL** Aluminium air tanks
- **ATANK-ST** Steel air tanks
- **TL-LED** Rear lights LED
- **BLIGHT-E** Emergency brake light
- WHEELS & TYRES**
- **RT-AL** Alcoa brushed aluminium rims with standard holes for long stud fixing on all axles
- **RT-ALDP** Alcoa Dura-Bright EVO aluminium rims with standard holes long stud fixing on all axles, requires cleaning with a ph neutral solution - washing up liquid.
- **RT-ALDPD** Alcoa Dura-Bright EVO aluminium rims with countersunk holes for short stud fixing on all axles, requires cleaning with a ph neutral solution - washing up liquid.
- **RT-ALDU** Alcoa brushed aluminium rims with countersunk holes for short stud fixing on all axles
- **RT-STEEL** Steel rims on all axles
- **WCAP** Aerodynamic hub caps
- **COREC002** Continental ECOPLUS HS3/HD3 - Energy rating B or C depending on size
- **GYREC001** Goodyear FUELMAX S/HL/D - Energy rating B or C depending on size
- **MIREC003** Michelin X-LINE Energy - Fuel tyre Recommendation 3
- **SPWT-D** Spare wheel & tyre with rear tyre pattern
- **SPWT-F** Spare wheel & tyre with front tyre pattern
- **SWCP-T** Spare wheel supplied temporarily strapped to chassis
- **SWCP-TP** Temporary spare wheel carrier on top of chassis frame
- **JACK-12T** 12 tonne bottle jack
- **TOOL-BAS** Basic Toolkit
- **TOOLKIT** Complete tool kit
- **INFLAHOS** Tyre inflation hose
- **GAUGE-TP** Tyre pressure gauge
- DRIVELINE EQUIPMENT**
- **TRAP-HD** Reinforced gearbox application
- **TP-CON** Construction Package
- **TP-DIST** Distribution Package
- **TP-LONG** Long Haul Package
- **AMSO-AUT** Enhanced I-shift software with manual shift available in auto mode and kickdown facility on accelerator pedal
- **AVO-ENH** Enhanced software for off road driveability and starting
- **APF-ENH** I-shift enhanced PTO functions
- **RET-TH** Gearbox mounted retarder
- **RET-TPT** Hydraulic Retarder for Powertronic gearbox
- **TC-MAOH2** Extra high performance transmission oil cooler - air to oil with front mounted radiator
- **TC-MWO** Basic transmission oil cooler - water to oil
- **2COM1100** Two cylinder, air compressor, 1100 litres per minute
- **2COMP900** Two cylinder, air compressor, 900 litres per minute
- **CLU-AIRC** Clutchable air compressor
- **AIRIN-HI** Roof mounted air intake behind cab on left hand side
- **AIRIN-LO** Low level air intake behind cab on left hand side
- **ACL1ST-S** Two stage air filter
- **24AL110B** 110 amp alternator
- **24AL120B** 120 amp alternator
- **24AL150B** 150 amp alternator
- **CCV-C** Closed crankcase engine ventilation
- **CCV-OX** Closed crankcase ventilation for cold markets
- **PRIM-EL** Electrical priming pump
- **PRIM-MAN** Manual priming pump
- **FUEQ-EH** Fuel line electric heater
- **AF-R** Hot fuel recirculation heated fuel filter
- **FUEFE2LW** Large engine mounted dual fuel filter with water separator
- **FUEFE2SW** Small engine mounted dual fuel filter with water separator
- **EST-AID** Air inlet manifold starting heater element
- **220EBH15** 220V/1.5Kw electric engine block heater
- **PTER-100** Rear engine mounted power-take-off with DIN 100 / ISO 7646 flange
- **PTER-DIN** Rear engine mounted PTO with DIN5462 (female) splined shaft for a close coupled pump. Models with 3 steering axles will use this to drive the steering pump (AUXPSP)
- **PTER1400** Rear engine mounted power-take-off with SAE 1410 flange
- **HPE-F101** Parker F1-101, engine mounted, fixed displacement, single flow, engine mounted hydraulic pump
- **HPE-F41** Parker F1-41, engine mounted, fixed displacement, single flow, engine mounted hydraulic pump
- Standard Equipment
- Optional Equipment

For more detailed information about cab and powertrain equipment, please refer to separate specification sheets.

For all possible options and combinations of options please consult your Volvo sales contact who can create a specification to match your requirements using the Volvo Sales Support system (VSS).

The factory reserves the right to modify design and change equipment without previous notification. The specification can vary from country to country.

# MODEL RANGE

## FM 11 4x2 Tractor - X-Low - Full Air Suspension FM 42 T1XA

- HPE-F51** Parker F1-51, engine mounted, fixed displacement, single flow, engine mounted hydraulic pump
- HPE-F61** Parker F1-61, engine mounted, fixed displacement, single flow, engine mounted hydraulic pump
- HPE-F81** Parker F1-81, engine mounted, fixed displacement, single flow, engine mounted hydraulic pump
- HPE-T53** Parker F2-53/53, engine mounted, Fixed displacement, Twin flow engine mounted hydraulic pump
- HPE-T70** Parker F2-70/35, engine mounted, Fixed displacement, Twin flow engine mounted hydraulic pump
- HPE-V45** Parker VP1-45, variable displacement, single flow, engine mounted hydraulic pump
- HPE-V75** Parker VP1-75, variable displacement, single flow, engine mounted hydraulic pump
  
- PTR-D** Gearbox PTO for plug-in pump, 0.71xeng speed
- PTR-DH** Gearbox driven high speed PTO for one plug-in hydraulic pump
- PTR-DM** Gearbox driven medium speed PTO for one plug-in hydraulic pump
- PTR-F** Gearbox driven PTO with rear flange connection
- PTR-FH** Gearbox driven high speed PTO with SAE drive flange
- PTR-FL** Gearbox driven low speed PTO with SAE drive flange
- PTRD-D** Gearbox driven HIGH SPEED PTO for two plug-in hydraulic pumps
- PTRD-D1** PTRD-D1 Gearbox driven HIGH SPEED PTO (1 SAE flange & 1 plug-in hydraulic pump)
- PTRD-D2** Gearbox driven HIGH SPEED PTO (2 SAE flanges & 1 plug-in hyd pump)
- PTRD-F** PTO with 1 DIN + 1 flange connection rear, manual gearbox
- HPG-F101** Parker F1-101 gearbox mounted, fixed displacement, single flow, hydraulic pump
- HPG-F41** Parker F1-41 gearbox mounted, fixed displacement, single flow, hydraulic pump
- HPG-F51** Parker F1-51 gearbox mounted, fixed displacement, single flow, hydraulic pump
- HPG-F61** Parker F1-61 gearbox mounted, fixed displacement, single flow, hydraulic pump
- HPG-F81** Parker F1-81 gearbox mounted, fixed displacement, single flow, hydraulic pump
  
- EIDLESD** Engine idle shut down
- DTRI-PER** Dashboard in darker peregrine greyish brown. Steering wheel grey and door panels in light beige for FH and black for FH16.
  
- **STWPOS-R** RIGHT HAND DRIVE
- STWM-LE** Leather steering wheel
- STGW-AD2** Adjustable steering wheel with neck tilt
- **STGW-ADJ** Adjustable steering wheel
- **AIRBAG** SRS Driver's air bag
- **DRC-AMII** DPF Regeneration control switch - for manual and switching off regeneration
- **1DAYDIG2** Continental VDO DTCO 4.0 smart tachograph  
This tachograph can ONLY offer remote download if the option of Dynafleet or an FMS gateway has been specified with this order.
- 1DAYDIGP** Continental VDO DTCO 3.0 digital tachograph  
For vehicles with long lead time - this includes prep kit for the retrofit of DTCO 4.0 tachograph.  
For updating to new legal demand for trick registration from 15th June 2019.  
This tachograph can ONLY offer remote download if the option of Dynafleet or an FMS gateway has been specified with this order.
- ARSL** Additional road speed limit - switch in dashboard
- CRUIS-E** Eco cruise control (with eco-roll and I-cruise, controls in steering wheel)
- **CRUISEC** Cruise control, standard
- **ESP-BAS1** Electronic Stability Control
  
- ESPC-RO** ESP (Electronic Stability Program) functionality control - Reduced / Off
- HWSS-ACB** Adaptive cruise control ACC with forward collision warning and AEBS advanced emergency brake system
- **HWSS-FCB** Forward collision warning with AEBS advanced emergency brake system
- **LSS-DW** Lane departure-warning system
- LCS** Lane change support
- DAS-W** Driver Alert Support system
- RSENS-W** Rain sensing windscreen wipers
- CU-ECC** Electrically controlled air conditioning with sun sensor
- CU-ECC2** Electrically controlled air conditioning with sun sensor, mist sensor, air quality sensor and carbon filter
- **CU-MCC** Climate unit with manual controlled air conditioning
- **IMMOBIL** Thatcham H2 approved immobiliser
- ALARM-B** Thatcham H1 approved vehicle alarm - Cab only
- ALARM-E** Enhanced vehicle alarm - Thatcham H1 approved - Cab plus external sensor for body/trailer
  
- ALCOLOCK** Alcolock
- BUPMON** Back up monitor with built in 7" screen on dash and one colour camera supplied loose for fitment by bodybuilder.  
Can accommodate up to 4 cameras for TfL Safe Scheme, CLOCS and FORS.
- PHONE-PK** Telephone preparation kit (antenna, antenna attachm. cable incl.)
- WLIFT-AD** Electrical window lift, automatic up/down driver side
- **WLIFT-EB** Electrical window lift
- WLIFT-ME** Mechanical window lift
- ISUNS-BS** Side interior sun visor on both sides
- **ISUNS-DS** Driver's side interior sun visor
- **ISUNF-B** Interior front sun visor without mirror
- ISUNF-MD** Interior front sun visor with mirror on driver side
- ISUNF-RE** Electrically operated textile interior sun blind
- ISUNF-RM** Manually operated textile interior sun blind
- ADFS** Two extra DIN slots in front shelf - can be fitted with card or drawer available as an accessory
- **BUPALARM** Reverse alarm
- RTOLL-PK** Road toll PREPARATION kit for trucks operating with "Toll Collect" in Germany
- LOADIND** Load indicator with central dashboard display
- REMC-MF** Multi-functio wireless remote control
- FIREXT3S** 3kg fire extinguisher mounted on seat base
- WARNVEST** High visibility warning vest - no sleeves
- AIDKIT** First aid kit
- AIDKIT1B** First aid kit
- WARNLAMP** Portable warning lamp
- LAMP-IN** Inspection lamp
- BULBKIT** Bulb and fuse kit
- WRITEPAD** Writing pad
- UPHTRI10** Seats: Black embossed textile insert with light grey sides, black vinyl side bolster with blue vinyl side insert.  
Interior trim: Raven black bunk and curtains & blue textile side walls
- UPHTRI11** Seats: Light grey embossed textile insert, black raven metallic vinyl bolster with red vinyl side insert.  
Interior trim: Raven black bunk and curtains & grey vinyl side walls
- UPHTRI12** Seats: Blue soft textile insert, black vinyl bolster.  
Interior trim: Raven black bunk and curtains & blue textile side

■ Standard Equipment

Optional Equipment

For more detailed information about cab and powertrain equipment, please refer to separate specification sheets.

For all possible options and combinations of options please consult your Volvo sales contact who can create a specification to match your requirements using the Volvo Sales Support system (VSS).

The factory reserves the right to modify design and change equipment without previous notification.  
The specification can vary from country to country.

# MODEL RANGE

FM 11 4x2 Tractor - X-Low - Full Air Suspension FM 42 T1XA

- UPHTR113** walls  
Seats: Dark grey leather insert and black leather bolster.  
Interior trim: Raven black bunk and curtains & grey vinyl side walls
- UPHTR114** walls  
Seat: Dark grey leather insert and black leather bolster.  
Interior trim: Raven black bunk and curtains & blue textile side walls
- DST-CF4** Driver seat, comfort, suspended, belt in seat
- DST-CF5** Driver seat, comfort, suspended, belt in seat, electrically heated
- DST-CF6** Driver seat, comfort, suspended, belt in seat, electrically heated, ventilated
- SBD-RED** Red seat belts
- SBPRE-DS** Driver seat belt pretensioner
- PST-BAS1** Passenger seat - Fixed non suspended fold up with seatbelt mounted in cab
- PST-BENC** Bench passenger seat
- PST-CF4** Passenger seat - Comfort suspended with seatbelt mounted in seat
- PST-CF5** Passenger seat - Comfort suspended & heated with seatbelt mounted in seat
- PST-STD2** Passenger seat - Fixed non suspended with seatbelt mounted in cab
- PST-STD4** Passenger seat - Standard suspended with seatbelt mounted in cab
- SBPRE-PS** Passenger seat belt pretensioner
- ARM-DBPS** Two armrests on driver seat and one (outer) on passenger seat
- ARMRE-BB** Two armrests on both driver and passenger seat.
- ARMRE-DB** Two armrests, on driver seat only
- ARMRE-PB** Two armrests, on passenger seat only
- ARMRE-PS** Single armrest (next to driver) on passenger seat
- ARU-BAS** Vinyl upholstered armrest
- ARU-LEA** Leather upholstered armrest
- FMAT-RUB** Rubber floor mats
- FMAT-TX2** Textile and rubber floor mats
- LBK-RES** Foldable rest bunk
- LBK70** Lower bunk 700 x2000 mm, fixed
- ULBK** Without lower bunk
- MATL-FI** Firm lower bunk pocket sprung mattress
- MATL-SF** Lower flexizone mattress - semi-firm, pocket springs up to 100kg - 16 stone
- MATL-SO** Lower flexizone mattress - soft, pocket springs up to 85kg - 13.5 stone
- OLMAT-BA** 35mm mattress overlay protector
- OLMAT-PR** 50mm premium mattress overlay protector
- TBK60F** Fixed foldable top bunk 600 x 1900mm
- TBK70F** Fixed foldable top bunk 700 x 1900mm
- PH-CAB2** 1.8kW Air to air night heater
- PH-ENGCA** Engine and cab night heater
- PH-SS** Short stop heater
- SLCP-BAS** Basic sleeper control panel - includes interior light, parking heater, roof hatch and door lock
- SAFE** Safe box for driver's personal items
- ETSB-F** Storage on engine tunnel - on front top
- ETSB-FR** Storage on engine tunnel - on front top and at rear cab wall
- ETSB-FRS** Storage on engine tunnel - on front top & at rear cab wall & storage recessed into tunnel on right hand side
- ETSB-FS** Storage on engine tunnel - on front top and storage recessed into tunnel on right hand side
- ETSB-R** Storage on engine tunnel - box at rear cab wall
- ETSB-RS** Storage on engine tunnel - at rear cab wall and storage recessed into tunnel on right hand side
- ETSB-S** Storage on engine tunnel - recessed into tunnel on right hand side
- RUS-BAS** Rear cab upper storage 154 litres - 300 mm high
- RUS-HIG** Rear cab upper storage 245 litres - 440 mm high
- TABLE** Folding and height adjustable table - on lower bunk
- REF-ICPK** Fridge: engine tunnel mounted preparation kit
- REFR-RUS** Fridge: 28 litre rear upper wall mounted with dividers
- MICRO-PK** Preparation kit for microwave oven (wiring)
- BOTH-D** One bottle holder under dashboard centre section
- COFMA-PK** Coffee maker, preparation kit.
- INLI-BAS** Interior white LED lights - basic
- INLI-NL** Interior white and red night LED light with no dimmer
- INLI-NLD** Interior white and red night LED light with dimmer
- ARL-FLEX** Two flexible reading lamps (snake lamps)
- RH-ECS** Glass roof & escape hatch - Electrically operated
- RH-EE** Without roof hatch -Tinted glass emergency exit ONLY
- RH-ETR** Glass roof & escape hatch - Electrically operated, tinted glass with rear opening
- RH-MSR** Steel roof & escape hatch - Manually operated with rear opening
- RH-MTR** Glass roof & escape hatch - Manually operated, tinted glass with rear opening
- URH** Without roof hatch
- SWIND-BS** Extra side window on both sides behind "B" pillar
- SWIND-PS** Rear side window, passenger side
- VANMIR** Vanity mirror in front shelf
- AS-FUS** Extra shelf in front upper storage compartments
- INFOT-PK** Preparation kit for the mounting of a flat screen TV in cab above the driver's door, includes bracket, electrical and speaker connections

## CAB EXTERIOR

- PAICS-B** Basic cab paint - mirrors, sunvisor, instep and bumper supplied in natural finish - grey
- PAICS-C** Complete cab - mirrors, insteps, sunvisor, and bumper finished in cab colour
- GLAS-TIN** Tinted windows.
- AWIND-RF** Rear window
- DGLAS-L** Laminated door glass
- LOCK-MAN** Manual door locking
- LOCK-MRP** Manual door locking with internal remote control (from driver side) of passenger door
- LOCK-REM** Central locking with remote control
- BUMP-B** Plastic front bumper
- BUMP-B2** Steel front bumper
- BUGNET** Insect screen in front of radiator
- CTILT-P-E** Electrically operated hydraulic cab tilt
- CTILT-P-M** Manually operated hydraulic cab tilt
- FCABS-A** Front cab suspension - Air
- FCABS-M** Front cab suspension - Mechanical spring
- RCABS-A** Rear cab suspension - Air
- RCABS-M** Rear cab suspension - Mechanical spring
- MIRCOMF2** Electrically heated and operated FMX style main and wide-angle mirror on both sides, with manual passenger kerb mirror. To increase direct vision to the side the main mirrors have no cowlings
- MIRCOMFM** Electrically heated and operated main with manual wide-angle mirror - both sides - and passenger kerb mirror
- MIRSTD2** Electrically heated - FMX - main with wide angle mirror on both sides and kerb view mirror on passenger side, to increase direct vision to the side the main mirrors have no cowlings
- MIRSTDFM** Electrically heated main mirror with wide angle mirror on both sides and kerb view mirror on passenger side
- AMIR-F20** Auxiliary front view mirror with a 200mm radius

Standard Equipment       Optional Equipment

For more detailed information about cab and powertrain equipment, please refer to separate specification sheets.

For all possible options and combinations of options please consult your Volvo sales contact who can create a specification to match your requirements using the Volvo Sales Support system (VSS).

The factory reserves the right to modify design and change equipment without previous notification. The specification can vary from country to country.

# MODEL RANGE

## FM 11 4x2 Tractor - X-Low - Full Air Suspension FM 42 T1XA

<input type="checkbox"/> <b>SUNV-H</b>	External smoke grey sunvisor	<input type="checkbox"/> <b>5WH17D37</b>	Fifth wheel leg-height 167 mm to 367mm
<input type="checkbox"/> <b>AD-ROOF</b>	Roof air deflector	<input type="checkbox"/> <b>5WH185</b>	Fifth wheel leg-height 185 mm
<input type="checkbox"/> <b>AD-SIDEL</b>	Side air deflector extension panels	<input type="checkbox"/> <b>5WH195</b>	Fifth wheel leg-height 195mm
<input type="checkbox"/> <b>AD-SIDES</b>	Short cab side air deflector for rigid bodywork	<input type="checkbox"/> <b>5WH200</b>	Fifth wheel leg-height 200 mm
<input checked="" type="checkbox"/> <b>HL-BASIC</b>	Halogen H7 head lamps	<input type="checkbox"/> <b>5WH205</b>	Fifth wheel leg-height 205 mm
<input type="checkbox"/> <b>HL-BHID</b>	High intensity Bi-Xenon head lamps	<input type="checkbox"/> <b>5WH210</b>	Fifth wheel leg-height 210 mm
<input type="checkbox"/> <b>HL-DBL</b>	Bi-Xenon high intensity discharge and dynamic head lamps. Dipped beam follows the road, activated by a signal from the steering system.	<input type="checkbox"/> <b>5WH220</b>	Fifth wheel leg-height 220mm
<input type="checkbox"/> <b>HL-CLEAN</b>	Head lamp cleaner - washer jets	<input type="checkbox"/> <b>5WH230</b>	Fifth wheel leg-height 230 mm
<input type="checkbox"/> <b>HLP-ST</b>	Headlamp protection	<input checked="" type="checkbox"/> <b>5WT-FO14</b>	Fontaine 150SP2 pressed steel fifth wheel
<input type="checkbox"/> <b>HL-ADJ</b>	Headlight adjustment - Switch in cab	<input type="checkbox"/> <b>5WT-FO15</b>	Fontaine 3000 lightweight cast fifth wheel with 150SF air operated slider - for moderate duty off road. Specified fifth wheel position always gives rearmost position.
<input type="checkbox"/> <b>DRIVL2</b>	Two spot lamps	<input type="checkbox"/> <b>5WT-JO10</b>	Jost JSK 36 pressed fifth wheel
<input checked="" type="checkbox"/> <b>UDRIVL</b>	Without auxiliary driving lights	<input type="checkbox"/> <b>5WT-JO8</b>	Jost JSK 37 cast fifth wheel
<input checked="" type="checkbox"/> <b>FOGL-WC</b>	Front fog lights	<input type="checkbox"/> <b>5WT-JO9</b>	Jost JSK 42 cast fixed fifth wheel
<input type="checkbox"/> <b>CL-STAT</b>	Static corner lights	<input type="checkbox"/> <b>5WT-SH</b>	SAF-Holland/+GF+ SK-S 36.20 cast fixed fifth wheel
<input type="checkbox"/> <b>ASL-RF2</b>	Two Hella H11 70W spotlamps in sign box - only available with the basic headlight and no lower driving lights.	<input checked="" type="checkbox"/> <b>5WLM-B</b>	Basic fifth wheel maintenance standard top plate
<input type="checkbox"/> <b>ASL-RFPK</b>	Preparation kit for two spotlamps in sign box	<input type="checkbox"/> <b>5WLM-L</b>	Low maintenance fifthwheel with nylon top plate
<input type="checkbox"/> <b>BEACO2F</b>	Two front roof mounted amber beacon rotating warning lamps	<input type="checkbox"/> <b>5WL-S1</b>	Fifth wheel lubrication - locking mechanism and top plate
<input type="checkbox"/> <b>BEACO2R</b>	Two rear roof mounted (on accessory bracket) amber beacon flashing warning LED lamps	<input type="checkbox"/> <b>5WL-S2</b>	Fifth wheel lubrication - locking mechanism
<input type="checkbox"/> <b>BEACON-P</b>	Roof beacon wire preparation	<input type="checkbox"/> <b>TCIND</b>	Trailer connection indication with sensors for height, kingpin and coupling lock
<input type="checkbox"/> <b>BEACONA4</b>	Four roof mounted (2 front/2 rear) amber beacon rotating warning lamps	<input checked="" type="checkbox"/> <b>RDECK</b>	Catwalk & step
<input type="checkbox"/> <b>CABPT-R1</b>	Single outlet for roof mounted accessories	<input type="checkbox"/> <b>RDECK-M</b>	Rear catwalk 760mm
<input checked="" type="checkbox"/> <b>CABPT-R2</b>	Twin outlets for roof mounted accessories.	<input type="checkbox"/> <b>SRWL-PK</b>	Wiring preparation for side & rear work/reverse lamps on side of chassis and a three-position switch, maximum 280W
<input type="checkbox"/> <b>SPOTP-F</b>	Spotlamp preparation in front, max 280W	<input type="checkbox"/> <b>SWL-2RA</b>	Two H3 35W amber rear chassis mounted (LH/RH side) working lamps and a 2-position switch (On/Off)
<input type="checkbox"/> <b>SPOTP-R</b>	Spotlamp preparation on roof, max 280W	<input type="checkbox"/> <b>SWL-2RW</b>	Two H3 70W white rear chassis mounted (LH/RH side) working lamps and a 2-position switch (On/Off)
<input type="checkbox"/> <b>SPOTP-RF</b>	Spotlamp preparation on cab roof and in cab front, max 2x280W	<input type="checkbox"/> <b>SWL-PK</b>	Wiring preparation for side work/reverse lamps on side of chassis and a three-position switch, maximum 280W
<input type="checkbox"/> <b>ROS-IL2</b>	Preparation kit for illuminated roof sign with switch loose in cab, fit after registration	<input checked="" type="checkbox"/> <b>WL-TA1W</b>	White coupling light
<input type="checkbox"/> <b>CSGN-GTR</b>	"Globetrotter" headboard logo	<input type="checkbox"/> <b>WLC-H2A</b>	Two H3/70W working lamps with amber coloured lens high mounted back of cab
<input checked="" type="checkbox"/> <b>HORN-F1S</b>	Single tone Jericho air horn chassis mounted	<input type="checkbox"/> <b>WLC-H2W</b>	Two H3/70W white working lamps high mounted on the back of cab
<input type="checkbox"/> <b>HORN-R2S</b>	Two roof mounted air horns	<input type="checkbox"/> <b>WLC-PKH</b>	Preparation kit, cables and switch for high mounted working lamps back of cab
<input type="checkbox"/> <b>ANT-CBR</b>	Roof mounted antenna for CB radio, single aerial	<input type="checkbox"/> <b>WLC-PKL</b>	Preparation kit, cables and switch for low mounted working lamps back of cab
<input type="checkbox"/> <b>ACCB-RM</b>	Rear & middle roof mounted accessory brackets	<input type="checkbox"/> <b>WLC-PKLH</b>	Preparation kit - cables and switch for low and high mounted working lamps back of cab.
<input type="checkbox"/> <b>ACCB-AP</b>	Front, middle & rear roof mounted accessory brackets	<input checked="" type="checkbox"/> <b>ECBB-BAS</b>	Body builder electrical centre without body builder module
<input type="checkbox"/> <b>ACCB-F</b>	Front roof mounted accessory bracket	<input type="checkbox"/> <b>ECBB-HIG</b>	Body builder electrical centre with body builder module
<input type="checkbox"/> <b>ACCB-FM</b>	Front & middle roof mounted accessory brackets	<input type="checkbox"/> <b>BBCHAS1</b>	One 7-pole connector for Body builder interface
<input type="checkbox"/> <b>ACCB-FR</b>	Front & rear roof mounted accessory brackets	<input type="checkbox"/> <b>BBCHAS3</b>	Three 7-pole connectors for Body builder interface
<input type="checkbox"/> <b>ACCB-M</b>	Middle roof mounted accessory bracket	<input type="checkbox"/> <b>BEPR-T2</b>	Body builder electrical software preparation for tipper with remote control
<input type="checkbox"/> <b>ACCB-R</b>	Rear roof mounted accessory bracket	<input type="checkbox"/> <b>EXSTER</b>	External steering control, with VDS and bodybuilder module
<input type="checkbox"/> <b>ACCB-RM</b>	Rear & middle roof mounted accessory brackets	<input type="checkbox"/> <b>TD-BAS</b>	Trailer detection WITHOUT LED sensing
<input type="checkbox"/> <b>RFCAR-BC</b>	Rear mudwing carrier, back of cab	<input checked="" type="checkbox"/> <b>TD-LED</b>	Trailer detection with LED sensing
<input type="checkbox"/> <b>LADDER</b>	Ladder back of cab	<input type="checkbox"/> <b>AUXL-SPK</b>	Electrical preparation kit - wiring and switch for snow plough lights
<input type="checkbox"/> <b>REFS-TW</b>	White cab conspicuity markings by packed in cab	<input type="checkbox"/> <b>TAILPRE2</b>	Tail lift preparation kit, wireless remote operation
<input type="checkbox"/> <b>REFS-TY</b>	Yellow cab conspicuity markings by packed in cab	<input type="checkbox"/> <b>TAILPREP</b>	Taillift preparation kit - cab switch and warning in driver display
<b>SUPERSTRUCTURE PREPARATIONS</b>			
<input type="checkbox"/> <b>5WM-ASM</b>	50mm high 'L' profiles for air actuated sliding 5th wheel	<input type="checkbox"/> <b>AESW2</b>	Two Body builder bistable electrical switches (marked AUX1 / AUX2)
<input type="checkbox"/> <b>5WM-DH</b>	Dual height 5th wheel mounting	<input type="checkbox"/> <b>AESW2PK</b>	2 Body builder bistable el.switches (marked AUX1/AUX2) and prep. for 4 more switches
<input type="checkbox"/> <b>5WM-ISOL</b>	5th wheel subframe 16mm high above chassis frame	<input type="checkbox"/> <b>AUXSW-4</b>	Wiring for 4 extra switches (from Body builder electrical centre to switch positions)
<input checked="" type="checkbox"/> <b>5WM-ISOM</b>	5th wheel subframe 60mm high above chassis frame	<b>DELIVERY SERVICES</b>	
<input type="checkbox"/> <b>5WM-LPRO</b>	5th wheel attached direct to frame with inverted 'L'-profiles	<input checked="" type="checkbox"/> <b>TGW-4GWL</b>	GSM/GPRS/4G modem, LTE & WLAN for telematics gateway
<input type="checkbox"/> <b>5WM-MASL</b>	4mm high 'L' profiles for manual sliding fifth wheel		
<input type="checkbox"/> <b>5WM-MASM</b>	50mm high 'L' profiles for manual sliding fifth wheel		
<input type="checkbox"/> <b>5WH140</b>	Fifth wheel leg-height 140 mm		
<input type="checkbox"/> <b>5WH150</b>	Fifth wheel leg-height 150 mm		
<input type="checkbox"/> <b>5WH160</b>	Fifth wheel leg-height 160 mm		
<input type="checkbox"/> <b>5WH175</b>	Fifth wheel leg height 175mm		

Standard Equipment

Optional Equipment

For more detailed information about cab and powertrain equipment, please refer to separate specification sheets.

For all possible options and combinations of options please consult your Volvo sales contact who can create a specification to match your requirements using the Volvo Sales Support system (VSS).

The factory reserves the right to modify design and change equipment without previous notification. The specification can vary from country to country.

# MODEL RANGE

FM 11 4x2 Tractor - X-Low - Full Air Suspension FM 42 T1XA

---

□ **FMS-PK** Fleet Management System gateway

**VOLVO**

Volvo Truck Corporation  
volvotrucks.com