

MODEL RANGE

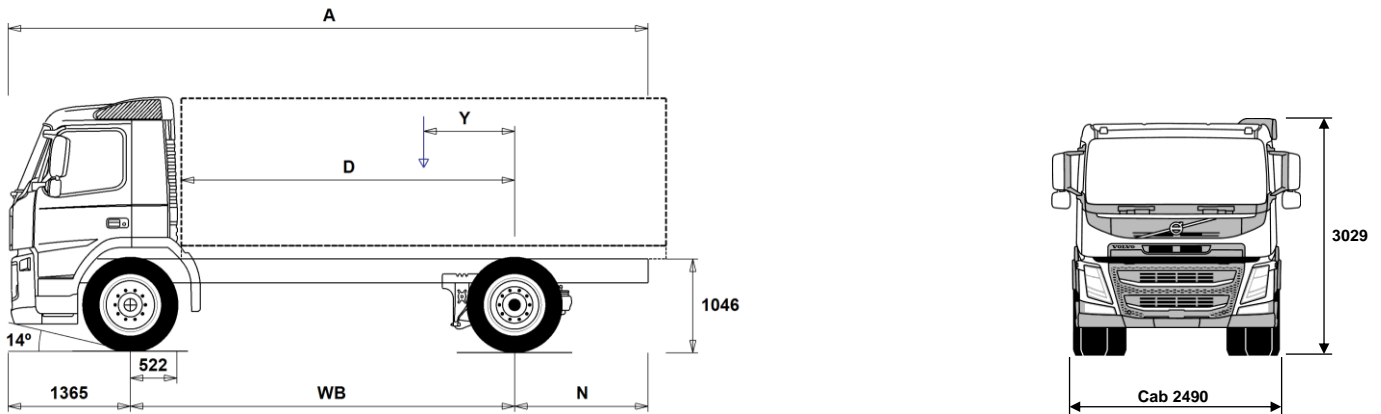

Volvo Trucks. Driving Progress

FM 11 4x2 Platform - Rear Air Suspension FM 42 R1HA



Chassis Dimensions [mm]

WB Wheelbase	3400	3700	4000	4300	4600	4900	5200	5600	6000	6300	6500	6700
A Overall Chassis Length	7160	7110	7510	8010	8510	8960	9460	10060	10660	11210	11410	11610
D Center of rear axle to front of body	2828	3128	3428	3728	4028	4328	4628	5028	5428	5728	5928	6128
N Rear Overhang (Min.)	1395	1395	1395	1395	1395	1395	1395	1395	1395	1395	1395	1395
N Rear Overhang (Max.)	2395	2045	2145	2345	2545	2695	2895	3095	3295	3545	3545	3545
Y Center of Gravity for Payload (Min.)	686	734	790	846	902	959	1017	1090	1163	1227	1262	1297
Y Center of Gravity for Payload (Max.)	856	919	991	1063	1135	1207	1282	1377	1471	1551	1597	1643

Chassis Weights [kg]

Front Axle	4140	4175	4185	4205	4220	4230	4235	4250	4270	4260	4270	4275
Rear Axle	1880	1840	1855	1895	1930	1955	1980	2015	2055	2075	2080	2085
Kerb Weight	6020	6015	6040	6100	6150	6185	6215	6265	6325	6335	6350	6360
Payload (including body, driver, fuel, etc.)	11980	11985	11960	11900	11850	11815	11785	11735	11675	11665	11650	11640

Turning Diameter [mm]

Turning Circle Diameter Kerb to Kerb	12400	13400	14300	15200	16100	17000	17900	19200	20400	21300	21900	22500
Turning Circle Diameter Wall to Wall	13900	14800	15700	16600	17600	18500	19400	20600	21900	22800	23400	24000

Plated Weights [kg]

	Plated	Design
Gross Vehicle Weight	18000	20100
Gross Combination Weight	40000	44000
Front Axle	7100	7100
Rear Axle	11500	13000

Important Notes

Chassis Dimensions

Cab Height: +416 mm for CAB-HSLP, -169 mm for CAB-LSLP, +554 mm for CAB-XHSL.

Front Axle to Back of Cab: +424 mm for CAB-HSLP and CAB-SLP and CAB-XHSL, +418 mm for CAB-LSLP.

D-measure includes a front clearance of 50 mm and for rigid trucks also a subframe of 100 mm.

Height can vary ± 20 mm for leaf and ± 10 mm for air suspension.

All dimensions are for unladen chassis and any tag axles down. Chassis height used: CHH-HIGH.

Rear overhang used for vehicle weight calculation is the maximum rear overhang (N Max.) for selected wheelbase.

Height change when chassis height CHH-MED, FRAME266: 0 mm.

Weight and dimensions are based upon the following tyres:

Front Axle Tyres:	315/80R22.5
Drive Axle Tyres:	315/80R22.5

Chassis weight includes oil, water, AdBlue, 0 litres fuel and without driver. Kerb weight can vary $\pm 3\%$.

Turning diameters are theoretically calculated.

Legal weights can differ from country to country.

For more detailed weight information, including optional equipment weights, ask your Volvo sales contact to enter your specification into the Volvo Weight Information system (WIS).

Do NOT use this drawing for bodybuilding. Refer to Volvo Bodybuilder Instructions and chassis assembly drawing FM42R1HA.

MODEL RANGE

FM 11 4x2 Platform - Rear Air Suspension FM 42 R1HA

TRUCK USE

- RC-ROUGH** Operating class on/off road
- RC-SMOOT** Operating class highway
- GARB-PRE** Garbage preparation
- TIPP-PRE** Tipper vehicle preparation
- UNIFORM** Basic platform vehicle

CORE COMPONENTS

- CHH-HIGH** Chassis height high - N3 "On Road" chassis - For a specific loading height always check the unique BEP chassis drawing
- CHH-MED** Chassis height medium - For a specific loading height always check the unique BEP chassis drawing
- RAD-GR** RAD-GR- 4x2 Air - High
- FM-DAY** Day cab - with steel safety cage design
Designed and built to Swedish impact and ECE R29 regulations
- FM-HSLP** Globetrotter cab - with steel safety cage design
Designed and built to Swedish impact and ECE R29 regulations
- FM-LSLP** Low sleeper cab - with steel safety cage design
Designed and built to Swedish impact and ECE R29 regulations
- FM-SLP** Sleeper cab - with steel safety cage design
Designed and built to Swedish impact and ECE R29 regulations
- FM-XHSL** Globetrotter LXL cab - with steel safety cage design
Designed and built to Swedish impact and ECE R29 regulations
- EU6SCR** Emission level - Euro 6
- D11K330** D11K330 10.8 litre engine developing 330hp at 16-1900rpm.
Peak torque 1600Nm at 950-1400rpm.
- D11K380** D11K380 10.8 litre engine developing 380hp at 17-1900rpm.
Peak torque 1800Nm at 950-1400rpm.
- D11K430** D11K430 10.8 litre engine developing 430hp at 17-1800rpm.
Peak torque 2050Nm at 1058-1400rpm.
- D11K460** D11K460 10.8 litre engine developing 450hp at 16-1800rpm.
Peak torque 2200Nm at 1050-1400rpm.
- EBR-EPG** Exhaust brake controlled by steering column switch
- EBR-EPGC** Exhaust pressure governor for I shift gearbox
- EBR-VEB** Volvo engine brake and exhaust pressure governor retardation 300kW
- AT2412F** AT2412F 12-speed "I-shift" automated mechanical gearbox suitable for gross train weights up to 44tonne only refer to sales engineering when used in conjunction with a PTO
- AT2612F** AT2612F 12-speed "I-shift" automated mechanical gearbox suitable for gross train weights up to 60tonne only refer to sales engineering when used in conjunction with a PTO
- ATO2612F** ATO2612F 12-speed "I-shift" overdrive automated mechanical gearbox suitable for gross train weights up to 60tonne refer to sales engineering when used in conjunction with a PTO
- PT2106** Powertronic automatic 6-speed gearbox, max. engine torque 2100 Nm, max. permitted GCW 100000 kg
- RSH1370F** RSH1370F hub reduction rear axle with differential lock - design GCW 70 tonne
- RSS1344E** RSS1344E single reduction rear axle with differential lock - design GCW 44tonne
- RSS1352A** RSS1352A single reduction 13 tonne rear axle with differential lock - design GCW 52 tonne
- RSS1356** RSS1356 single reduction rear axle with differential lock - design GCW 56 tonne
- RSS1370A** RSS1370A single reduction 13 tonne rear axle with differential lock - design GCW 70 tonne
- RSS1370B** RSS1370B single reduction 13 tonne rear axle with differential lock - design GCW 70 tonne

PACKAGES

- Standard Equipment
- Optional Equipment

For more detailed information about cab and powertrain equipment, please refer to separate specification sheets.

For all possible options and combinations of options please consult your Volvo sales contact who can create a specification to match your requirements using the Volvo Sales Support system (VSS).

The factory reserves the right to modify design and change equipment without previous notification. The specification can vary from country to country.

- LHFP-VE** Long Haul Fuel Economy driving package
- DRIVEFM** Cab Package: Drive
- DRIVEFM+** Cab Package: Drive +
- BEDFM** One bed resting package
- AUDHIG** High Power Audio system: RDS radio with CD player - also playing MP3/WMA files from CD -, with integrated bluetooth phone and USB/Line inputs. FM/AM antenna, speakers in dashboard, doors, and sleeping compartment.
- MEDIA** AM/FM Bluetooth radio without CD player. USB and Aux line inputs. Speakers in dashboard, doors, and sleeping compartment. 7" touch screen with personal apps.
- MEDIADF** AM/FM Bluetooth radio without CD player. USB and Aux line inputs. Speakers in dashboard, doors, and sleeping compartment. 7" touch screen with personal and professional apps. Dynafleet vehicle on-board data display with office internet support.
- MEDIANAV** AM/FM Bluetooth radio without CD player. USB and Aux line inputs. Speakers in dashboard, doors, and sleeping compartment. 7" touch screen with personal and professional apps. Truck based satellite navigation (live updates not included) AM/FM Bluetooth radio without CD player. USB and Aux line inputs. Speakers in dashboard, doors, and sleeping compartment. 7" touch screen with personal and professional apps. Truck based satellite navigation (live updates not included) Dynafleet vehicle on-board data display with office internet support.
- VISI15** Visibility Package
- VISI15+** Visibility Plus Package
- ASAF15** Active Safety Package
- RCHAPAC1** Chassis Package Rigid
- CHASSIS**
 - FST-AIR** Front suspension type - air
 - FST-PAR** Front suspension type - 2 leaf parabolic springs
 - FST-PAR3** Front suspension type - 3 leaf parabolic springs
 - FSL5-BAS** Front suspension levelling - basic stroke
 - FSL5-HI** Front suspension levelling - high stroke for demount operations - check with bodybuilder
 - FAL10.0** Front axle design capacity 10 tonnes - Ensure that you have checked the tyre load index
 - FAL7.1** Front axle design capacity 7.1 tonnes
 - FAL7.5** Front axle design capacity 7.5 tonnes
 - FAL8.0** Front axle design capacity 8.0 tonnes - Ensure that you have checked the tyre load index
 - FAL8.5** Front axle design capacity 8.5 tonnes
 - FAL9.0** Front axle design capacity 9.0 tonnes - Ensure that you have checked the tyre load index
 - FSM-LUB** Lubricated rear shackles on front suspension pins and bushings
 - FSTAB** Front anti-roll bar
 - FSTAB2** Front anti-roll bar medium stiffness
 - FSTAB3** Front stiff anti-roll bar
 - RAL13** Rear axle design capacity 13 tonnes
 - RSTAB3** Rear stiff anti-roll bar
 - ASF-DL1** Air suspension with 1 driving level
 - ASF-DL3** Air suspension with 3 driving levels
 - ACTST-TO** Volvo Dynamic Steering (VDS) with with extra electronic pump and torque overlay
 - ASFE-BAS** Active steering feature - Basic - Volvo Dynamic Steering only
 - ASFE-PS** Active steering feature - Volvo Dynamic Steering with personal settings
 - PSS-SING** Single power steering system

MODEL RANGE

FM 11 4x2 Platform - Rear Air Suspension FM 42 R1HA

- **PSP-FIX** Power steering pump with fixed displacement
- **PSP-VAR** Power steering pump with variable displacement
- **EBS-MED** EBS medium package including "hill" hold function
- **AUXPARK** Additional spring parking brakes
- **FBREG-E** Front regulating brake valve, EBS
- **SUSPL-EC** Remote electronic control on wander-lead for air suspension levelling
- **FRAME266** Frame rail section external height 266 mm
- **FRAME300** Frame rail section external height 300 mm
- **FST6060** Frame thickness - web and flange 6.0mm
- **FST7070** Frame thickness - web and flange 7.0mm
- **FST8080** Frame thickness - web and flange 8.0mm
- **FIL-EEEB** Inner liner from end of engine to end of bogie
- **FIL-EEEF** Inner liner from end of engine to end of frame
- **FIL-TXEB** Inner liner from gearbox member to end of bogie
- **FIL-TXEF** Inner liner from gearbox member to end of frame
- **BBOX-L** Battery box located on left hand side
- **2BAT210B** 2 x 210 Ah capacity Gel batteries
- **2BATT170** 2 x 170 Ah capacity batteries
- **2BATT225** 2 x 225 Ah capacity batteries
- **BATTAMP** Battery voltage and ampere gauge
- **BATTIND** Battery charge indication
- **ADR2** ADR package for transportation of dangerous goods on road (Note does NOT include safe loading pass package if required this is quoted separately)
- **MSWI-A** Main switch - ADR switch circuit shut down
- **MSWI-C** Main switch - Chassis mounted toggle switch by battery box
- **MSWI-R** Main switch - Key fob operated remote controlled
- **R330A71** Right aluminium 710 mm D-shaped fuel tank, 330 litres volume
Min volume 255l
Max volume 885l
- **UL-FUEL** Without left fuel tank
Min volume 160l
Max volume 730l
- **ADTP-L** AdBlue tank on left hand side
- **ADTP-R** AdBlue tank on right hand side
- **ADB048** AdBlue tank usable volume 48 litres
- **ADB064** AdBlue tank usable volume 64 litres
- **ADB068** AdBlue tank usable volume 68 litres
- **ADB090** AdBlue tank usable volume 90 litres
- **ADB100** AdBlue tank usable volume 100 litres
- **ADTC-BF** AdBlue tank cover with satin alloy look decorative cover
- **FCAP-L** Locking fuel filler cap
- **FUFF-AS** Fuel filling anti-spillage device
- **FUFF-ATS** Fuel filling anti-theft and anti-spillage devices
- **ESH-LEFT** Horizontal silencer, left exhaust outlet
- **ESH-REAR** Horizontal silencer, rear exhaust outlet
- **ESH-RIGH** Horizontal silencer, right exhaust outlet
- **ESH-VERT** Horizontal silencer, vertical exhaust outlet
- **EXST-SSP** Stainless steel exhaust stack - NOT polished
- **EXST-ST** Steel exhaust stack
- **HS-NAR** Narrow heat shield
- **WHC-FIX1** One fixed wheel chock
- **WHC-FIX2** Two fixed wheel chocks
- **WHC-FOL1** One foldable wheel chock
- **WHC-FOL2** Two foldable wheel chocks
- **WHCP-F** Wheel chock(s) stored in the front part of the vehicle
- **WHCP-M** Wheel chock(s) stored in the middle part of the vehicle
- **WHCP-R** Wheel chock(s) stored in the rear part of the vehicle
- **WHCP-T** Transport mounted wheel chock(s) stored in cab outer luggage locker
- **TB-R80** Toolbox 800 mm, right side
- **SUP-BAS** EC approved chassis side guards
- **CHAIN-S** Snow chains
- **HOOK-SC** Snow chain hooks
- **TOWF-NO1** One front towing device
- **TOWF-NO2** Two front towing devices
- **TOWMBRH** Towing member, high mounted in centre of frame, D = 190
- **TOWMBRL1** Towing member, low mounted under the frame
- **TOWMBRL2** Towing member, low and forward mounted under the frame
- **TOWMBRL3** Towing member, low and far forward mounted under the frame
- **TOWMBRM** Towing member, medium mounted in line with frame lower flange
- **RFEC-L** Rear frame end, lower flange cut for centre axle drawbar.
- **RFEC-S** Rear frame end, straight cut for regular platform applications
- **RFEC-U** Rear frame end, upper cut for tipper applications.
- **C-RI4040** Towing coupling, Ringfeder 4040 G-150
- **C-RI5055** Towing coupling, Ringfeder 5055 G-150
- **C-RO400G** Towing coupling, Rockinger 400 G-150 for 40mm eyes
- **C-RO50** Rockinger RO 50 50mm for centre axle trailer
- **TOWR-ONE** Towing hitch attached to rear crossmember
- **TREL-PK** Trailer electrical preparation kit - chassis/cab wiring
- **TREL14** Single 14 pole electrical trailer connector
- **TREL15** Single 15 pole electrical trailer connector - ADR certified
- **TREL7** 7 pole - 24N trailer electrical suzie
- **TREL7-7** 24N and 24S trailer electrical suzies
- **TBC-DUO** Duomatic type air line connectors
- **TBC-EC** Palm coupling type air line connectors
- **TRBR-HCF** Full pressure hand controlled trailer brake
- **TRBR-STA** Stationary trailer brake control
- **TRB-STRE** Stretch Brake - Automatic low speed trailer brake activation to avoid jack-knifing and improve steerability
- **RUP-FOLD** Folding EC approved aluminium rear underrun
- **RUP-FOSL** Folding & sliding EC approved aluminium rear underrun
- **RFEND-B** Three piece EC approved rear mud wings and spray flaps
- **RFEND-T** Rear mud wings, transport mounted
- **RFH-BAS** Basic rear wing height
- **RFH-HIG** High rear wing height - higher wing tops
- **RFH-LOW** Lower rear wing height - shallower wing tops
- **ATANK-AL** Aluminium air tanks
- **ATANK-ST** Steel air tanks
- **TL-LED** Rear lights LED
- **BLIGHT-E** Emergency brake light

WHEELS & TYRES

- **RT-AL** Alcoa brushed aluminium rims with standard holes for long stud fixing on all axles
- **RT-ALDP** Alcoa Dura-Bright EVO aluminium rims with standard holes long stud fixing on all axles, requires cleaning with a ph neutral solution - washing up liquid.
- **RT-ALDPD** Alcoa Dura-Bright EVO aluminium rims with countersunk holes for short stud fixing on all axles, requires cleaning with a ph neutral solution - washing up liquid.
- **RT-ALDU** Alcoa brushed aluminium rims with countersunk holes for short stud fixing on all axles
- **RT-STEEL** Steel rims on all axles
- **WCAP** Aerodynamic hub caps
- **BRREC002** Bridgestone Ecopia H 002 Evo - Tyre recommendation 2
- **COREC001** Continental ECOPLUS HS3 XL/HD3 - Energy rating B or C depending on size
- **COREC002** Continental ECOPLUS HS3/HD3 - Energy rating B or C depending on size
- **COREC003** Continental Efficient Pro S/D - Fuel Tyre Recommendation 3 Reduced mileage compared to Conti EcoPlus long haul pattern please consider when selecting these tyres.

■ Standard Equipment □ Optional Equipment

For more detailed information about cab and powertrain equipment, please refer to separate specification sheets.

For all possible options and combinations of options please consult your Volvo sales contact who can create a specification to match your requirements using the Volvo Sales Support system (VSS).

The factory reserves the right to modify design and change equipment without previous notification. The specification can vary from country to country.

MODEL RANGE

FM 11 4x2 Platform - Rear Air Suspension FM 42 R1HA

<input type="checkbox"/> GYREC002	Goodyear FUELMAX S/D - Energy rating B or C depending on size	<input type="checkbox"/> EST-AID	Air inlet manifold starting heater element
<input type="checkbox"/> GYREC003	Goodyear FUELMAX S/(O)/D - Fuel tyre Recommendation 3	<input type="checkbox"/> 220EBH15	220V/1.5Kw electric engine block heater
<input type="checkbox"/> GYREC004	Goodyear FUELMAX S - Energy rating B depending on size	<input type="checkbox"/> PTER-100	Rear engine mounted power-take-off with DIN 100 / ISO 7646 flange
<input type="checkbox"/> HAREC001	Hankook AL10+ E-Cube Max Long Haul Tyre - Energy rating B	<input type="checkbox"/> PTER-DIN	Rear engine mounted PTO with DIN5462 (female) splined shaft for a close coupled pump. Models with 3 steering axles will use this to drive the steering pump (AUXPSP)
<input type="checkbox"/> HAREC002	Hankook AL10+ E-Cube Long Haul Tyre - Energy rating B with wide single	<input type="checkbox"/> PTER1400	Rear engine mounted power-take-off with SAE 1410 flange
<input type="checkbox"/> MIREC001	Michelin XFA2/X-LINE Energy - Fuel tyre Recommendation 1	<input type="checkbox"/> HPE-F101	Parker F1-101, engine mounted, fixed displacement, single flow, engine mounted hydraulic pump
<input type="checkbox"/> MIREC002	Michelin XZA2/X-LINE Energy - Fuel tyre Recommendation 2	<input type="checkbox"/> HPE-F41	Parker F1-41, engine mounted, fixed displacement, single flow, engine mounted hydraulic pump
<input type="checkbox"/> MIREC003	Michelin X-LINE Energy - Fuel tyre Recommendation 3	<input type="checkbox"/> HPE-F51	Parker F1-51, engine mounted, fixed displacement, single flow, engine mounted hydraulic pump
<input type="checkbox"/> MIREC004	Michelin X Line Energy F/D2 - Energy rating A	<input type="checkbox"/> HPE-F61	Parker F1-61, engine mounted, fixed displacement, single flow, engine mounted hydraulic pump
<input type="checkbox"/> PIREC001	Pirelli FH:01 Proway - Long Haul Tyre - Energy rating B	<input type="checkbox"/> HPE-F81	Parker F1-81, engine mounted, fixed displacement, single flow, engine mounted hydraulic pump
<input type="checkbox"/> PIREC002	Pirelli FH:01 II Long Haul Tyre - Energy rating B with wide single	<input type="checkbox"/> HPE-T53	Parker F2-53/53, engine mounted, Fixed displacement, Twin flow engine mounted hydraulic pump
<input type="checkbox"/> SPWT-D	Spare wheel & tyre with rear tyre pattern	<input type="checkbox"/> HPE-T70	Parker F2-70/35, engine mounted, Fixed displacement, Twin flow engine mounted hydraulic pump
<input type="checkbox"/> SPWT-F	Spare wheel & tyre with front tyre pattern	<input type="checkbox"/> HPE-V45	Parker VP1-45, variable displacement, single flow, engine mounted hydraulic pump
<input type="checkbox"/> SWCP-LF	Spare wheel carrier on left side of chassis ahead of rear axle	<input type="checkbox"/> HPE-V75	Parker VP1-75, variable displacement, single flow, engine mounted hydraulic pump
<input type="checkbox"/> SWCP-R	Rear mounted spare wheel carrier	<input type="checkbox"/> PTPT-D	Powertronic PTO, 1 front/upper DIN connection for plug-in pump (max. 850 Nm)
<input type="checkbox"/> SWCP-T	Spare wheel supplied temporarily strapped to chassis	<input type="checkbox"/> PTPT-F	Powertronic PTO, 1 front/upper rear facing SAE flange conn. for prop shaft (max.850 Nm)
<input type="checkbox"/> SWCP-TP	Temporary spare wheel carrier on top of chassis frame	<input type="checkbox"/> PTR-D	Gearbox PTO for plug-in pump, 0.71xeng speed
<input type="checkbox"/> JACK-12T	12 tonne bottle jack	<input type="checkbox"/> PTR-DH	Gearbox driven high speed PTO for one plug-in hydraulic pump
<input type="checkbox"/> JACK-15T	15 tonne bottle jack	<input type="checkbox"/> PTR-DM	Gearbox driven medium speed PTO for one plug-in hydraulic pump
<input type="checkbox"/> JACK-20T	20 tonne bottle jack	<input type="checkbox"/> PTR-F	Gearbox driven PTO with rear flange connection
<input checked="" type="checkbox"/> TOOL-BAS	Basic Toolkit	<input type="checkbox"/> PTR-FH	Gearbox driven high speed PTO with SAE drive flange
<input type="checkbox"/> TOOLKIT	Complete tool kit	<input type="checkbox"/> PTR-FL	Gearbox driven low speed PTO with SAE drive flange
<input type="checkbox"/> INFLAHOS	Tyre inflation hose	<input type="checkbox"/> PTRD-D	Gearbox driven HIGH SPEED PTO for two plug-in hydraulic pumps
<input type="checkbox"/> GAUGE-TP	Tyre pressure gauge	<input type="checkbox"/> PTRD-D1	PTRD-D1 Gearbox driven HIGH SPEED PTO (1 SAE flange & 1 plug-in hydraulic pump)
DRIVELINE EQUIPMENT		<input type="checkbox"/> PTRD-D2	Gearbox driven HIGH SPEED PTO (2 SAE flanges & 1 plug-in hyd pump)
<input type="checkbox"/> TRAP-HD	Reinforced gearbox application	<input type="checkbox"/> PTRD-F	PTO with 1 DIN + 1 flange connection rear, manual gearbox
<input type="checkbox"/> TP-CON	Construction Package	<input type="checkbox"/> HPG-F101	Parker F1-101 gearbox mounted, fixed displacement, single flow, hydraulic pump
<input type="checkbox"/> TP-DIST	Distribution Package	<input type="checkbox"/> HPG-F41	Parker F1-41 gearbox mounted, fixed displacement, single flow, hydraulic pump
<input type="checkbox"/> TP-LONG	Long Haul Package	<input type="checkbox"/> HPG-F51	Parker F1-51 gearbox mounted, fixed displacement, single flow, hydraulic pump
<input type="checkbox"/> AMSO-AUT	Enhanced I-shift software with manual shift available in auto mode and kickdown facility on accelerator pedal	<input type="checkbox"/> HPG-F61	Parker F1-61 gearbox mounted, fixed displacement, single flow, hydraulic pump
<input type="checkbox"/> AVO-ENH	Enhanced software for off road driveability and starting	<input type="checkbox"/> HPG-F81	Parker F1-81 gearbox mounted, fixed displacement, single flow, hydraulic pump
<input type="checkbox"/> APF-ENH	I-shift enhanced PTO functions	<input type="checkbox"/> EIDLESD	Engine idle shut down
<input type="checkbox"/> RET-TH	Gearbox mounted retarder	<input type="checkbox"/> DTRI-PER	Dashboard in darker peregrine greyish brown. Steering wheel grey and door panels in light beige for FH and black for FH16.
<input type="checkbox"/> RET-TPT	Hydraulic Retarder for Powertronic gearbox	<input checked="" type="checkbox"/> STWPOS-R	RIGHT HAND DRIVE
<input type="checkbox"/> TC-HWO	Automatic gearbox oil cooler - water to oil	<input type="checkbox"/> STWM-LE	Leather steering wheel
<input type="checkbox"/> TC-MAOH2	Extra high performance transmission oil cooler - air to oil with front mounted radiator	<input type="checkbox"/> STGW-AD2	Adjustable steering wheel with neck tilt
<input type="checkbox"/> TC-MWO	Basic transmission oil cooler - water to oil	<input checked="" type="checkbox"/> STGW-ADJ	Adjustable steering wheel
<input type="checkbox"/> 1COMP530	Single cylinder, air compressor, 530 litres per minute	<input checked="" type="checkbox"/> AIRBAG	SRS Driver's air bag
<input type="checkbox"/> 2COM1100	Two cylinder, air compressor, 1100 litres per minute	<input checked="" type="checkbox"/> DRC-AMII	DPF Regeneration control switch - for manual and switching off regeneration
<input checked="" type="checkbox"/> 2COMP900	Two cylinder, air compressor, 900 litres per minute	<input checked="" type="checkbox"/> 1DAYDIG2	Continental VDO DTCO 4.0 smart tachograph This tachograph can ONLY offer remote download if the option
<input type="checkbox"/> CLU-AIRC	Clutchable air compressor		
<input checked="" type="checkbox"/> AIRIN-HI	Roof mounted air intake behind cab on left hand side		
<input type="checkbox"/> AIRIN-LO	Low level air intake behind cab on left hand side		
<input type="checkbox"/> ACL1ST-S	Two stage air filter		
<input checked="" type="checkbox"/> 24AL110B	110 amp alternator		
<input type="checkbox"/> 24AL120B	120 amp alternator		
<input type="checkbox"/> 24AL150B	150 amp alternator		
<input checked="" type="checkbox"/> CCV-C	Closed crankcase engine ventilation		
<input type="checkbox"/> CCV-O	Open crankcase engine breather		
<input type="checkbox"/> CCV-OX	Closed crankcase ventilation for cold markets		
<input checked="" type="checkbox"/> PRIM-EL	Electrical priming pump		
<input type="checkbox"/> PRIM-MAN	Manual priming pump		
<input type="checkbox"/> FUEQ-EH	Fuel line electric heater		
<input type="checkbox"/> AF-R	Hot fuel recirculation heated fuel filter		
<input type="checkbox"/> FUEFE2LW	Large engine mounted dual fuel filter with water separator		
<input checked="" type="checkbox"/> FUEFE2SW	Small engine mounted dual fuel filter with water separator		

Standard Equipment

Optional Equipment

For more detailed information about cab and powertrain equipment, please refer to separate specification sheets.

For all possible options and combinations of options please consult your Volvo sales contact who can create a specification to match your requirements using the Volvo Sales Support system (VSS).

The factory reserves the right to modify design and change equipment without previous notification. The specification can vary from country to country.

MODEL RANGE

FM 11 4x2 Platform - Rear Air Suspension FM 42 R1HA

- of Dynafleet or an FMS gateway has been specified with this order.
- 1DAYDIGP** Continental VDO DTCO 3.0 digital tachograph
For vehicles with long lead time - this includes prep kit for the retrofit of DTCO 4.0 tachograph.
For updating to new legal demand for truck registration from 15th June 2019.
This tachograph can ONLY offer remote download if the option of Dynafleet or an FMS gateway has been specified with this order.
 - ARSL** Additional road speed limit - switch in dashboard
 - SPEED-DU** Dual speed limiter
 - CRUIS-E** Eco cruise control (with eco-roll and I-cruise, controls in steering wheel)
 - CRUISEC** Cruise control, standard
 - ESP-BAS1** Electronic Stability Control
 - ESPC-RO** ESP (Electronic Stability Program) functionality control - Reduced / Off
 - HWSS-ACB** Adaptive cruise control ACC with forward collision warning and AEBS advanced emergency brake system
 - HWSS-FCB** Forward collision warning with AEBS advanced emergency brake system
 - LSS-DW** Lane departure-warning system
 - LCS** Lane change support
 - DAS-W** Driver Alert Support system
 - RSENS-W** Rain sensing windscreen wipers
 - CU-ECC** Electrically controlled air conditioning with sun sensor
 - CU-ECC2** Electrically controlled air conditioning with sun sensor, mist sensor, air quality sensor and carbon filter
 - CU-MCC** Climate unit with manual controlled air conditioning
 - IMMOBIL** Thatcham H2 approved immobiliser
 - ALARM-B** Thatcham H1 approved vehicle alarm - Cab only
 - ALARM-E** Enhanced vehicle alarm - Thatcham H1 approved - Cab plus external sensor for body/trailer
 - ALCOLOCK** Alcolock
 - BUPMON** Back up monitor with built in 7" screen on dash and one colour camera supplied loose for fitment by bodybuilder.
Can accommodate up to 4 cameras for TfL Safe Scheme, CLOCS and FORS.
 - PHONE-PK** Telephone preparation kit (antenna, antenna attachm. cable incl.)
 - WLIFT-AD** Electrical window lift, automatic up/down driver side
 - WLIFT-EB** Electrical window lift
 - WLIFT-ME** Mechanical window lift
 - ISUNS-BS** Side interior sun visor on both sides
 - ISUNS-DS** Driver's side interior sun visor
 - ISUNF-B** Interior front sun visor without mirror
 - ISUNF-MD** Interior front sun visor with mirror on driver side
 - ISUNF-RE** Electrically operated textile interior sun blind
 - ISUNF-RM** Manually operated textile interior sun blind
 - ADFS** Two extra DIN slots in front shelf - can be fitted with card or drawer available as an accessory
 - BUPALARM** Reverse alarm
 - RTOLL-PK** Road toll PREPARATION kit for trucks operating with "Toll Collect" in Germany
 - LOADIND** Load indicator with central dashboard display
 - REMC-MF** Multi-functio wireless remote control
 - FIREXT3S** 3kg fire extinguisher mounted on seat base
 - WARNVEST** High visibility warning vest - no sleeves
 - AIDKIT** First aid kit
 - AIDKIT1B** First aid kit
 - WARNLAMP** Portable warning lamp
 - LAMP-IN** Inspection lamp
 - BULBKIT** Bulb and fuse kit
 - WRITEPAD** Writing pad
 - UPHTRI10** Seats: Black embossed textile insert with light grey sides, black vinyl side bolster with blue vinyl side insert.
Interior trim: Raven black bunk and curtains & blue textile side walls
 - UPHTRI11** Seats: Light grey embossed textile insert, black raven metallic vinyl bolster with red vinyl side insert.
Interior trim: Raven black bunk and curtains & grey vinyl side walls
 - UPHTRI12** Seats: Blue soft textile insert, black vinyl bolster.
Interior trim: Raven black bunk and curtains & blue textile side walls
 - UPHTRI13** Seats: Dark grey leather insert and black leather bolster.
Interior trim: Raven black bunk and curtains & grey vinyl side walls
 - UPHTRI14** Seat: Dark grey leather insert and black leather bolster.
Interior trim: Raven black bunk and curtains & blue textile side walls
 - DST-CF4** Driver seat, comfort, suspended, belt in seat
 - DST-CF5** Driver seat, comfort, suspended, belt in seat, electrically heated
 - DST-CF6** Driver seat, comfort, suspended, belt in seat, electrically heated, ventilated
 - SBD-RED** Red seat belts
 - SBPRE-DS** Driver seat belt pretensioner
 - PST-BAS1** Passenger seat - Fixed non suspended fold up with seatbelt mounted in cab
 - PST-BENC** Bench passenger seat
 - PST-CF4** Passenger seat - Comfort suspended with seatbelt mounted in seat
 - PST-CF5** Passenger seat - Comfort suspended & heated with seatbelt mounted in seat
 - PST-STD2** Passenger seat - Fixed non suspended with seatbelt mounted in cab
 - PST-STD4** Passenger seat - Standard suspended with seatbelt mounted in cab
 - SBPRE-PS** Passenger seat belt pretensioner
 - ARM-DBPS** Two armrests on driver seat and one (outer) on passenger seat
 - ARMRE-BB** Two armrests on both driver and passenger seat.
 - ARMRE-DB** Two armrests, on driver seat only
 - ARMRE-PB** Two armrests, on passenger seat only
 - ARMRE-PS** Single armrest (next to driver) on passenger seat
 - ARU-BAS** Vinyl upholstered armrest
 - ARU-LEA** Leather upholstered armrest
 - FMAT-RUB** Rubber floor mats
 - FMAT-TX2** Textile and rubber floor mats
 - LBK-RES** Foldable rest bunk
 - LBK70** Lower bunk 700 x2000 mm, fixed
 - ULBK** Without lower bunk
 - MATL-FI** Firm lower bunk pocket sprung mattress
 - MATL-SF** Lower flexizone mattress - semi-firm, pocket springs up to 100kg - 16 stone
 - MATL-SO** Lower flexizone mattress - soft, pocket springs up to 85kg - 13.5 stone
 - OLMAT-BA** 35mm mattress overlay protector
 - OLMAT-PR** 50mm premium mattress overlay protector
 - TBK60F** Fixed foldable top bunk 600 x 1900mm
 - TBK70F** Fixed foldable top bunk 700 x 1900mm
- Standard Equipment Optional Equipment

For more detailed information about cab and powertrain equipment, please refer to separate specification sheets.

For all possible options and combinations of options please consult your Volvo sales contact who can create a specification to match your requirements using the Volvo Sales Support system (VSS).

The factory reserves the right to modify design and change equipment without previous notification. The specification can vary from country to country.

MODEL RANGE

FM 11 4x2 Platform - Rear Air Suspension FM 42 R1HA

- PH-CAB2** 1.8kW Air to air night heater
 - PH-ENGCA** Engine and cab night heater
 - PH-SS** Short stop heater
 - SLCP-BAS** Basic sleeper control panel - includes interior light, parking heater, roof hatch and door lock
 - SAFE** Safe box for driver's personal items
 - ETSB-F** Storage on engine tunnel - on front top
 - ETSB-FR** Storage on engine tunnel - on front top and at rear cab wall
 - ETSB-FRS** Storage on engine tunnel - on front top & at rear cab wall & storage recessed into tunnel on right hand side
 - ETSB-FS** Storage on engine tunnel - on front top and storage recessed into tunnel on right hand side
 - ETSB-R** Storage on engine tunnel - box at rear cab wall
 - ETSB-RS** Storage on engine tunnel - at rear cab wall and storage recessed into tunnel on right hand side
 - ETSB-S** Storage on engine tunnel - recessed into tunnel on right hand side
 - RUS-BAS** Rear cab upper storage 154 litres - 300 mm high
 - RUS-HIG** Rear cab upper storage 245 litres - 440 mm high
 - TABLE** Folding and height adjustable table - on lower bunk
 - REF-ICPK** Fridge: engine tunnel mounted preparation kit
 - REFR-RUS** Fridge: 28 litre rear upper wall mounted with dividers
 - MICRO-PK** Preparation kit for microwave oven (wiring)
 - BOTH-D** One bottle holder under dashboard centre section
 - COFMA-PK** Coffee maker, preparation kit.
 - INLI-BAS** Interior white LED lights - basic
 - INLI-NL** Interior white and red night LED light with no dimmer
 - INLI-NLD** Interior white and red night LED light with dimmer
 - ARL-FLEX** Two flexible reading lamps (snake lamps)
 - RH-ECS** Glass roof & escape hatch - Electrically operated
 - RH-EE** Without roof hatch -Tinted glass emergency exit ONLY
 - RH-ETR** Glass roof & escape hatch - Electrically operated, tinted glass with rear opening
 - RH-MSR** Steel roof & escape hatch - Manually operated with rear opening
 - RH-MTR** Glass roof & escape hatch - Manually operated, tinted glass with rear opening
 - URH** Without roof hatch
 - SWIND-BS** Extra side window on both sides behind "B" pillar
 - SWIND-PS** Rear side window, passenger side
 - VANMIR** Vanity mirror in front shelf
 - AS-FUS** Extra shelf in front upper storage compartments
 - INFOT-PK** Preparation kit for the mounting of a flat screen TV in cab above the driver's door, includes bracket, electrical and speaker connections
- CAB EXTERIOR**
- PAICS-B** Basic cab paint - mirrors, sunvisor, instep and bumper supplied in natural finish - grey
 - PAICS-C** Complete cab - mirrors, insteps, sunvisor, and bumper finished in cab colour
 - GLAS-TIN** Tinted windows.
 - AWIND-RF** Rear window
 - DGLAS-L** Laminated door glass
 - LOCK-MAN** Manual door locking
 - LOCK-MRP** Manual door locking with internal remote control (from driver side) of passenger door
 - LOCK-REM** Central locking with remote control
 - BUMP-B** Plastic front bumper
 - BUMP-B2** Steel front bumper
 - BUMP-SP** Front bumper spoiler
- GUARD-EH** Engine guard to protect sump and engine hoses
 - BUGNET** Insect screen in front of radiator
 - CTILT-P-E** Electrically operated hydraulic cab tilt
 - CTILT-P-M** Manually operated hydraulic cab tilt
 - FCABS-A** Front cab suspension - Air
 - FCABS-M** Front cab suspension - Mechanical spring
 - RCABS-A** Rear cab suspension - Air
 - RCABS-M** Rear cab suspension - Mechanical spring
 - MIRCOMF2** Electrically heated and operated FMX style main and wide-angle mirror on both sides, with manual passenger kerb mirror. To increase direct vision to the side the main mirrors have no cowlings
 - MIRCOMFM** Electrically heated and operated main with manual wide-angle mirror - both sides - and passenger kerb mirror
 - MIRSTD2** Electrically heated - FMX - main with wide angle mirror on both sides and kerb view mirror on passenger side, to increase direct vision to the side the main mirrors have no cowlings
 - MIRSTDFM** Electrically heated main mirror with wide angle mirror on both sides and kerb view mirror on passenger side
 - AMIR-F20** Auxiliary front view mirror with a 200mm radius
 - SUNV-H** External smoke grey sunvisor
 - AD-ROOF** Roof air deflector
 - AD-SIDEL** Side air deflector extension panels
 - AD-SIDES** Short cab side air deflector for rigid bodywork
 - HL-BASIC** Halogen H7 head lamps
 - HL-BHID** High intensity Bi-Xenon head lamps
 - HL-DBL** Bi-Xenon high intensity discharge and dynamic head lamps. Dipped beam follows the road, activated by a signal from the steering system.
 - HL-CLEAN** Head lamp cleaner - washer jets
 - HLP-ST** Headlamp protection
 - HL-ADJ** Headlight adjustment - Switch in cab
 - DRIVL2** Two spot lamps
 - UDRIVL** Without auxiliary driving lights
 - FOGL-WC** Front fog lights
 - CL-STAT** Static corner lights
 - ASL-RF2** Two Hella H11 70W spotlamps in sign box - only available with the basic headlight and no lower driving lights.
 - ASL-RFPK** Preparation kit for two spotlamps in sign box
 - BEACOA2F** Two front roof mounted amber beacon rotating warning lamps
 - BEACOA2R** Two rear roof mounted (on accessory bracket) amber beacon flashing warning LED lamps
 - BEACON-P** Roof beacon wire preparation
 - BEACONA4** Four roof mounted (2 front/2 rear) amber beacon rotating warning lamps
 - CABPT-R1** Single outlet for roof mounted accessories
 - CABPT-R2** Twin outlets for roof mounted accessories.
 - SPOTP-F** Spotlamp preparation in front, max 280W
 - SPOTP-R** Spotlamp preparation on roof, max 280W
 - SPOTP-RF** Spotlamp preparation on cab roof and in cab front, max 2x280W
 - ROS-IL2** Preparation kit for illuminated roof sign with switch loose in cab, fit after registration
 - CSGN-GTR** "Globetrotter" headboard logo
 - HORN-F1S** Single tone Jericho air horn chassis mounted
 - HORN-R2S** Two roof mounted air horns
 - ANT-CBR** Roof mounted antenna for CB radio, single aerial
 - ACCBR-AP** Front, middle & rear roof mounted accessory brackets
 - ACCBR-F** Front roof mounted accessory bracket
 - ACCBR-FM** Front & middle roof mounted accessory brackets
 - ACCBR-FR** Front & rear roof mounted accessory brackets

Standard Equipment

Optional Equipment

For more detailed information about cab and powertrain equipment, please refer to separate specification sheets.

For all possible options and combinations of options please consult your Volvo sales contact who can create a specification to match your requirements using the Volvo Sales Support system (VSS).

The factory reserves the right to modify design and change equipment without previous notification. The specification can vary from country to country.

MODEL RANGE

FM 11 4x2 Platform - Rear Air Suspension FM 42 R1HA

- ACCBR-M** Middle roof mounted accessory bracket
- ACCBR-R** Rear roof mounted accessory bracket
- ACCBR-RM** Rear & middle roof mounted accessory brackets
- REFS-TW** White cab conspicuity markings by packed in cab
- REFS-TY** Yellow cab conspicuity markings by packed in cab
- TGW-4GWL** GSM/GPRS/4G modem, LTE & WLAN for telematics gateway
- FMS-PK** Fleet Management System gateway

SUPERSTRUCTURE PREPARATIONS

- SRWL-PK** Wiring preparation for side & rear work/reverse lamps on side of chassis and a three-position switch, maximum 280W
- SWL-2FW** Two H3 70W white front chassis mounted (LH/RH side) working lamps and a 2-position switch (On/Off)
- SWL-2RW** Two H3 70W white rear chassis mounted (LH/RH side) working lamps and a 2-position switch (On/Off)
- SWL-4W** 4 H3 70W white front (2) & rear (2) chassis mtd (LH/RH side) working lamps & 2-pos switch (On/Off)
- SWL-PK** Wiring preparation for side work/reverse lamps on side of chassis and a three-position switch, maximum 280W
- WLC-H2A** Two H3/70W working lamps with amber coloured lens high mounted back of cab
- WLC-H2W** Two H3/70W white working lamps high mounted on the back of cab
- WLC-PKCH** Preparation kit (cables and switch) for cab mounted chassis working lamp
- WLC-PKH** Preparation kit, cables and switch for high mounted working lamps back of cab
- WLC-PKL** Preparation kit, cables and switch for low mounted working lamps back of cab
- WLC-PKLH** Preparation kit - cables and switch for low and high mounted working lamps back of cab.
- ECBB-BAS** Body builder electrical centre without body builder module
- ECBB-HIG** Body builder electrical centre with body builder module
- BBCHAS1** One 7-pole connector for Body builder interface
- BBCHAS3** Three 7-pole connectors for Body builder interface
- BEPR-T2** Body builder electrical software preparation for tipper with remote control
- EXSTER** External steering control, with VDS and bodybuilder module
- TD-BAS** Trailer detection WITHOUT LED sensing
- TD-LED** Trailer detection with LED sensing
- FRFS-BS** Frame rail free space on both sides to give space for crane legs or other equipment.
- FBA-BTF** Lower front body attachments for torsionally flexible - platform body
- FBA-BTSF** Lower front body attachments for torsionally semi-flexible body - box or curtainsider
- HBA-FSFB** Holes for body attachments - flexible/semi-flexible body
- HBA-SB** Holes for body attachments - stiff body
- RBA-T2** Lower rear body attachments for helper frame
- CRANEPK1** Crane plates mounted to frame, for cranes up to 10 tonne metre capacity
- CRANEPK2** Crane plates mounted to frame, for cranes up to 20 tonne metre capacity
- CRANEPK4** Crane plates mounted to frame, for cranes up to 40 tonne metre capacity
- AUXL-SPK** Electrical preparation kit - wiring and switch for snow plough lights
- TAILPRE2** Tail lift preparation kit, wireless remote operation
- TAILPREP** Taillift preparation kit - cab switch and warning in driver display
- AESW2** Two Body builder bistable electrical switches (marked AUX1 / AUX2)
- AESW2PK** 2 Body builder bistable el.switches (marked AUX1/AUX2) and prep. for 4 more switches
- AUXSW-4** Wiring for 4 extra switches (from Body builder electrical centre to switch positions)

DELIVERY SERVICES



Volvo Truck Corporation
volvotrucks.com