

MODEL RANGE

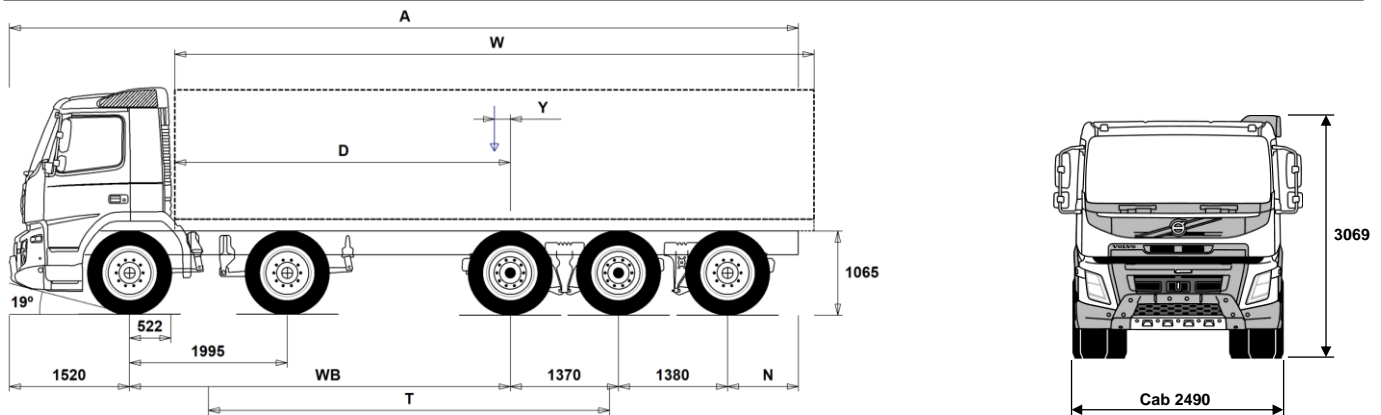

Volvo Trucks. Driving Progress

FMX D13 104 RIGID FAA20, TRIDEM FM104FTR3HAX



Chassis Dimensions [mm]

WB Wheelbase	4300	4350	4600	4900	5100	5600	6000
A Overall Chassis Length	9815	11315	11415	11865	11865	11515	11515
D Center of rear axle to front of body	3728	3778	4028	4328	4528	5028	5428
N Rear Overhang (Min.)	895	1245	1245	1245	1245	1245	895
N Rear Overhang (Max.)	1245	2695	2545	2695	2495	1645	1245
T Theoretical Wheelbase	4561	4611	4861	5161	5361	5861	6261
Y Center of Gravity for Payload (Min.)	24	56	129	223	280	419	533
Y Center of Gravity for Payload (Max.)	24	56	129	223	280	419	533
W Body Length (Min.)	7407	7443	7797	8209	8496	9218	9789
W Body Length (Max.)	7407	7443	7797	8209	8496	9218	9789

Chassis Weights [kg]

Front Axles	6895	6800	6800	6760	6775	6795	6805
Rear Bogie	3735	3945	3990	4070	4080	4050	4070
Kerb Weight	10630	10745	10790	10830	10855	10845	10875
Payload (including body, driver, fuel, etc.)	32370	32255	32210	32170	32145	32155	32125

Turning Diameter [mm]

Turning Circle Diameter Kerb to Kerb	18100	18200	19000	20000	20600	22200	23500
Turning Circle Diameter Wall to Wall	19500	19700	20500	21400	22100	23700	25000

Plated Weights [kg]

	Design
Gross Vehicle Weight	43000
Gross Combination Weight	44000
Front Axles	16000
Rear Bogie	27000

Important Notes

Chassis Dimensions

Cab Height: +416 mm for CAB-HSLP, +554 mm for CAB-XHSL.
Front Axle to Back of Cab: +424 mm for CAB-HSLP and CAB-SLP and CAB-XHSL.

D-measure includes a front clearance of 50 mm and for rigid trucks also a subframe of 100 mm.

Height can vary ± 20 mm for leaf and ± 10 mm for air suspension.

All dimensions are for unladen chassis and any tag axles down. Chassis height used: CHH-HIGH.

Rear overhang used for vehicle weight calculation is the maximum rear overhang (N Max.) for selected wheelbase.

Height change when chassis height CHH-MED, FRAME300: 0 mm.

Weight and dimensions are based upon the following tyres:

Front Axle Tyres:	315/80R22.5
Drive Axle Tyres:	315/80R22.5
Trailing/Pusher Axle Tyres:	315/80R22.5

Chassis weight includes oil, water, AdBlue, 0 litres fuel and without driver. Kerb weight can vary $\pm 3\%$.

Turning diameters are theoretically calculated. Tag axle used: TA-HYDRS.

Legal weights can differ from country to country.

For more detailed weight information, including optional equipment weights, ask your Volvo sales contact to enter your specification into the Volvo Weight Information system (WIS).

Do NOT use this drawing for bodybuilding. Refer to Volvo Bodybuilder Instructions and chassis assembly drawing FM104FTR3HAX.

MODEL RANGE

FMX D13 104 RIGID FAA20, TRIDEM FM104FTR3HAX

Transport operation

- RC-ROUGH** Rough road conditions.
 - Less than 95% of the driven distance on well maintained or less maintained surfaced roads.
 - and / or
 - In total not more than 5% of the driven distance on:
 - Very badly maintained surfaced roads.
 - Hard packed sand or gravel surface of very bad quality.
 - Washboards.
 - Soft unpaved surface.
 - Off-road.
- RC-SMOOT** Smooth road conditions.
At least 95% of the driven distance on well maintained or less maintained surfaced roads.
Driving occurs on:
 - Badly maintained surfaced roads.
 - Hard packed sand or gravel surface of good or bad quality.
- TIPP-PRE** Tipper vehicle preparation
- UNIFORM** Basic platform vehicle

Core components

- CHH-HIGH** Chassis height high - approx. 1000 mm above ground level
- CHH-MED** Chassis height medium - approx. 900 mm above ground level
- TA-HYSBS** El. hydraulically steered tag axle with single wheels (two wheels on complete axle) and steering lock out at 38 km/h
- RADDT-GR** Rear air suspension, 3 axles - 2 driven / 1 tag
- FMX-DAY** FMX Day cab
- FMX-HSLP** FMX Globetrotter sleeper cab
- FMX-SLP** FMX Sleeper cab
- EU6SCR** Euro 6 emission level with Selective Catalytic Reduction (SCR), particulate filter and Exhaust Gas Recirculation (EGR)
- D13 420S** Diesel engine with Turbo-S, 12.8 litre Euro 6 SCR + EGR (Diesel Particulate Filter), 420 hp, 2100 Nm
- D13 460S** Diesel engine with Turbo-S, 12.8 litre Euro 6 SCR + EGR (Diesel Particulate Filter), 460 hp, 2300 Nm
- D13 500S** Diesel engine with Turbo-S, 12.8 litre Euro 6 SCR + EGR (Diesel Particulate Filter), 500 hp, 2500 Nm
- D13 540S** Diesel engine Turbo-S, 12.8 litre Euro 6 SCR + EGR (Diesel Particulate Filter), 540 hp, 2600 Nm
- D13K420** Diesel engine, 12.8 litre Euro 6 SCR + EGR (Diesel Particulate Filter), 420 hp
- D13K460** Diesel engine, 12.8 litre Euro 6 SCR + EGR (Diesel Particulate Filter), 460 hp
- D13K500** Diesel engine, 12.8 litre Euro 6 SCR + EGR (Diesel Particulate Filter), 500 hp.
- D13K540** Diesel engine, 12.8 litre Euro 6 SCR + EGR (Diesel Particulate Filter), 540 hp
- DIESEL** Diesel fuel
- DIESEL-B** Biodiesel
- EBR-EPGC** Volvo engine compression brake with exhaust pressure governor, EPG (for I-shift)
- EBR-VEB** Volvo Engine Brake, VEB (compression brake with exhaust pressure governor, EPG)
- EBR-VEB+** Volvo Engine Brake, VEB+ (high efficiency compression brake with exhaust pressure governor, EPG)
- AT2412F** I-Shift automated mechanical 12-speed gearbox without clutch pedal, max. engine torque 2400 Nm, max. permitted GCW 44000 kg.
- AT2612F** I-Shift automated mechanical 12-speed gearbox without clutch pedal, max. engine torque 2600 Nm, max. permitted GCW 100000 kg.
- ATO2612F** I-Shift automated mechanical 12-speed overdrive gearbox without clutch, max. engine torque 2600 Nm, max. permitted GCW 100000 kg.
Suitable for hub reduction rear axles.
- SPO2812** Semi power shift dual clutch 12-speed overdrive gearbox, max. engine torque 2800 Nm, max permitted GCW 80 000 kg.
- RTH2610F** Rear hub reduction tandem axles - bogie load 26 tonnes, GCW 100 tonnes, version F

Standard Equipment

Optional Equipment

For more detailed information about cab and powertrain equipment, please refer to separate specification sheets.

For all possible options and combinations of options please consult your Volvo sales contact who can create a specification to match your requirements using the Volvo Sales Support system (VSS).

The factory reserves the right to modify design and change equipment without previous notification. The specification can vary from country to country.

- RTS2310A** Rear single reduction tandem axle - bogie load 23 tonnes, GCW 100 tonnes
- RTS2370A** Rear single reduction tandem axles - bogie load 23 tonnes, GCW 70 tonnes

Packages

- EDITION** Exterior Striping/Emblem. Model specific design on FH,FM,FH16 and FMX
- DRIVEFM** Driving package FM
- DRIVEFM+** Driving plus package FM
- BEDFM** Bed resting package FM
- AUDBAS** Audio basic. RDS radio with CD player, FM/AM antenna and speakers in dashboard & doors.
Prepared for Dynafleet office internet portal support.
High power audio system. RDS radio with CD player (also playing mp3/wma/wav files from CD), FM/AM antenna, speakers in dashboard & doors & sleeping compartment, integrated bluetooth phone and USB/Line inputs.
Prepared for Dynafleet office internet portal support.
- AUDHIG** Media package with infotainment. Prepared for both Dynafleet vehicle onboard support and for Dynafleet office internet portal support.
- MEDIADF** Media package with infotainment and Navigation support and prepared for Dynafleet vehicle onboard support and for Dynafleet office internet portal support.
- MEDIANDF** Media package with infotainment and Navigation support and prepared for Dynafleet vehicle onboard support and for Dynafleet office internet portal support.
- VISIX15** Visibility package FMX
- ENOPT** Energy optimization package
- ENOPT+** Energy optimization+ package
- OFFRFMXD** Construction package for FMX day cab
- OFFRFMXS** Construction package for FMX sleeper cabs
- RCHAPAC1** Rigid chassis package

Chassis

- FST-AIR** Front air suspension
- FST-PAR** 2 leaf front parabolic suspension (normal stiffness)
- FST-PAR3** 3 leaf front parabolic suspension (stiffer than normal)
- FSLB-BAS** Front air suspension basic levelling stroke
- FSLB-HI** Front air suspension high levelling stroke
- FAL16.0** Front axle load 16.0 tonnes, double front axles
- FAL18.0** Front axle load 18.0 tonnes, double front axles
- FAL20.0** Front axle load 20.0 tonnes, double front axles
- FALIM** Front axle load limiter
- FSTAB** Front stabilizer with normal stiffness
- FSTAB2** Front stabilizer with medium high stiffness
- FSTAB3** Front stiff stabilizer
- RAL27** Rear axles load 27 tonnes
- RAL33** Rear axles load 33 tonnes
- RAL36** Rear axles load 36 tonnes
- RSTAB3** Rear stiff stabilizer
- RALIM105** First rear drive axle load limiter, 10.5 tonnes (speed controlled)
- RALIM115** First rear drive axle load limiter, 11.5 tonnes (speed controlled)
- RALIM13** First rear drive axle load limiter, 13 tonnes
- RALIM95** First rear drive axle load limiter, 9.5 tonnes
- ACTST-TO** Volvo Dynamic Steering (VDS) with extra pump and torque overlay
- ASFE-BAS** Volvo Dynamic Steering feature basic
- ASFE-PS** Volvo Dynamic Steering personal settings
- PSP-VAR** Power steering pump with variable displacement
- EBS-MED** EBS (Electronic Brake System) medium package:
 - ABS (Anti-lock Braking System)
 - Lining Wear Sensing (20 % left)
 - Lining Wear Control (incl. wear on the axle)
 - Brake Blending
 - Drag Torque Control
 - Diff Lock Synchronization

MODEL RANGE

FMX D13 104 RIGID FAA20, TRIDEM FM104FTR3HAX

	- Diff lock Control		- RIGID, 1 front axle, Fold, 1/2 w chocks	= Top of left side battery box
	- Brake Temperature Warning		- RIGID, 2 front axles, Fold, Frame free space, 2 wc	= Top of left side battery box
	- External Brake Demand		- RIGID, 2 front axles, Fix, W/o frame free space, 2 wc	= Left frame behind 1st front wheel
	- Diagnosis Via Truck Electronic System		- RIGID, 1 front axle, Fix, 1/2 w chocks	= Left frame rear (or front) of rear wheels
	- Traction Control System	<input type="checkbox"/> WHCP-R	Wheel chock(s) in the rear part of the vehicle	
	- Emergency Brake Assistance	<input type="checkbox"/> WHCP-T	Transport mounted wheel chock(s) in cab outer luggage compartment	
	- Constant Wheel Brake Monitoring	<input type="checkbox"/> TB-L80	Left toolbox 800 mm length (mounting length 800 mm, real length 730 mm)	
	- Coupling Force Control	<input type="checkbox"/> TB-R80	Right toolbox 800 mm length (mounting length 800 mm, real length 730 mm)	
	- Automatic Parking Brake Activation	<input type="checkbox"/> SUP-BAS	Standard aluminium bars for side underrun protection	
	- Lining Wear Analyses (calc of remaining mileage)	<input type="checkbox"/> CHAIN-S	Snow chains	
	- Hill Starting Assistance	<input type="checkbox"/> HOOK-SC	Snow chain hooks. Rear mounted for tractors and side mounted in rear overhang for rigids. Two hooks on each side.	
	- EBS status monitoring via Truck Electronic System	<input type="checkbox"/> TOWF-HD1	One heavy duty front towing device	
<input type="checkbox"/> AUXPARK	Two extra parking brake chambers	<input type="checkbox"/> TOWMBRH	High mounted towing member, in centre of frame	
<input checked="" type="checkbox"/> FRAME300	Frame rail section external height 300 mm	<input type="checkbox"/> TOWMBRL1	Towing member, low mounted under the frame (position 1)	
<input checked="" type="checkbox"/> FST8080	Frame section thickness - web 8.0 mm / flange 8.0 mm	<input type="checkbox"/> TOWMBRM	Towing member, medium mounted in line with frame lower flange	
<input checked="" type="checkbox"/> FIL-EEEB	Frame inner liner from end of engine end to end of bogie	<input checked="" type="checkbox"/> RFEC-S	Rear frame end, straight cut (for regular platform applications)	
<input type="checkbox"/> FIL-EEEF	Frame inner liner from end of engine end to end of frame	<input type="checkbox"/> RFEC-U	Rear frame end, upper cut (for e.g. tipper, refuse and hooklift applications)	
<input checked="" type="checkbox"/> BBOX-L	Battery box on left hand side	<input type="checkbox"/> C-RI4040	Towing coupling Ringfeder RF4040A G-150	
<input type="checkbox"/> 2BAT210B	Gel batteries 2x210 Ah	<input type="checkbox"/> C-RI4045	Towing coupling Ringfeder RF4045A G-150	
<input checked="" type="checkbox"/> 2BATT170	Batteries 2x170 Ah	<input type="checkbox"/> C-RI5055	Towing coupling Ringfeder RF5055A G-150	
<input type="checkbox"/> 2BATT225	Batteries 2x225 Ah	<input type="checkbox"/> C-RO400G	Towing coupling Rockinger 400 G-150	
<input checked="" type="checkbox"/> BATTAMP	Battery voltage and ampere gauge	<input type="checkbox"/> C-RO50	Towing coupling Rockinger 50 mm	
<input type="checkbox"/> BATTIND	Battery voltage, ampere and battery status gauge with visual alerts	<input type="checkbox"/> C-VBG750	Towing coupling VBG 750V	
<input type="checkbox"/> ADR2	ADR adaptation - transportation of dangerous goods, 2 switches (1 inside cab in dashboard, 1 outside on cab back passenger side).	<input type="checkbox"/> C-VBG850	Towing coupling VBG 850V	
<input type="checkbox"/> MSWI-A	ADR main switch - ADR switch circuit shut down	<input type="checkbox"/> TOWR-ONE	One rear towing device in frame end cross member	
<input checked="" type="checkbox"/> MSWI-C	Chassis main switch - battery box placed toggle switch circuit shut down	<input checked="" type="checkbox"/> TREL-PK	Trailer electrical preparation kit (chassis/cab wiring)	
<input type="checkbox"/> MSWI-R	Remote controlled main switch - key fob operated circuit shut down	<input type="checkbox"/> TREL15	15 pol electrical trailer connector (ADR certified)	
<input checked="" type="checkbox"/> UR-FUEL	Without right diesel tank Min volume 255l Max volume 810l	<input type="checkbox"/> TREL7-7	2x7 pol (24N+24S) electrical trailer connectors (UADR)	
<input checked="" type="checkbox"/> UL-FUEL	Without left diesel tank Min volume 160l Max volume 450l	<input type="checkbox"/> TBC-DUO	Trailer brake connection, Duomatic	
<input type="checkbox"/> ADTP-L	AdBlue tank on left hand side (for dual front axles between the axles)	<input type="checkbox"/> TBC-EC	Trailer brake connection, European Community	
<input type="checkbox"/> ADTP-LF	AdBlue tank on left hand side at the front	<input type="checkbox"/> TRBR-STA	Stationary trailer brake control	
<input checked="" type="checkbox"/> ADTP-R	AdBlue tank on right hand side	<input type="checkbox"/> TRB-STRE	Automatic low speed trailer brake activation (stretch brake) to avoid jack-knifing and to improve steerability	
<input type="checkbox"/> ADB032	AdBlue tank usable volume 32 litres	<input type="checkbox"/> RUP-FOSL	Foldable and slidable aluminium rear underrun protection, EC approved	
<input type="checkbox"/> ADB048	AdBlue tank usable volume 48 litres	<input type="checkbox"/> FFEND-B	Standard mounted fenders on second front axle	
<input type="checkbox"/> ADB064	AdBlue tank usable volume 64 litres	<input type="checkbox"/> FFEND-T	Transport mounted fenders on second front axle	
<input type="checkbox"/> ADTC-BF	AdBlue tank cover painted in silver metallic	<input type="checkbox"/> RFEND-B	Rear 3 piece fenders with anti-spray function (all rear axles)	
<input checked="" type="checkbox"/> FCAP-L	Lockable diesel and AdBlue tank caps	<input type="checkbox"/> RFEND-T	Transport mounted one-piece rear fenders	
<input checked="" type="checkbox"/> FUFF-AS	Fuel filling anti-spillage device	<input type="checkbox"/> RFH-BAS	Optimal fender installation (rear and 2nd front axle) with regard to legal demands, wheel/tyre sizes, chassis height and fifth wheel height.	
<input type="checkbox"/> FUFF-ATS	Fuel filling anti-theft and anti-spillage devices	<input type="checkbox"/> RFH-HIG	Highest fender installation (rear and 2nd front axle). Suitable for rough and very rough road conditions.	
<input type="checkbox"/> ESH-LEFT	Horizontal muffler, left exhaust outlet	<input type="checkbox"/> RFH-LOW	Lower fender installation (rear and 2nd front axle). Suitable only for smooth road conditions. Increased risk of fender top wear.	
<input checked="" type="checkbox"/> ESH-REAR	Horizontal muffler, rear exhaust outlet	<input type="checkbox"/> ATANK-AL	Aluminium air tanks	
<input type="checkbox"/> ESH-VERT	Horizontal muffler, vertical exhaust outlet on right hand side	<input checked="" type="checkbox"/> ATANK-ST	Steel air tanks	
<input type="checkbox"/> ESHVERT	Horizontal and vertical muffler, vertical exhaust	<input type="checkbox"/> TL-LED	LED tail lamps (tail light, exterior marker light, brake light, hazard warning light, reverse light, rear fog light, licence plate light and reflector).	
<input type="checkbox"/> EXST-SSP	Bright polished vertical stainless steel exhaust top pipe			
<input type="checkbox"/> EXST-ST	Aluminized steel vertical exhaust top pipe			
<input type="checkbox"/> WHC-FIX2	Two fixed wheel chocks			
<input checked="" type="checkbox"/> WHC-FOL2	2 foldable wheel chocks			
<input type="checkbox"/> WHCP-F	Wheel chock(s) in the front part of the vehicle. - TRACTOR, BBOX-L, Fold, 1/2 w chocks = Top of left side battery box - TRACTOR, BBOX-EF, Fold, 1/2 w chocks = Top of lefts side fuel tank - TRACTOR, BBOX-EF, Fix, 2 w chocks = Left frame front of fuel tank			

Standard Equipment

Optional Equipment

For more detailed information about cab and powertrain equipment, please refer to separate specification sheets.

For all possible options and combinations of options please consult your Volvo sales contact who can create a specification to match your requirements using the Volvo Sales Support system (VSS).

The factory reserves the right to modify design and change equipment without previous notification. The specification can vary from country to country.

MODEL RANGE

FMX D13 104 RIGID FAA20, TRIDEM FM104FTR3HAX

- BLIGHT-E** Emergency brake light
- FRACLOS** Frame end closing
- Rims and Tyres**
- RT-AL** Brushed aluminium rims with std holes (long stud fixing) on all axles
- RT-ALDP** Dura-Bright polished aluminium rims with std holes (long stud fixing) on all axles
- RT-ALDPD** Dura-Bright polished aluminium rims with countersunk holes (short stud fixing) on all axles
- RT-ALDU** Brushed aluminium rims with countersunk holes (short stud fixing) on all axles
- RT-STEEL** Steel rims on all axles
- WCAP** Wheel caps
- SPWT-D** Spare wheel with tyre equal to drive
- SPWT-F** Spare wheel with tyre equal to front wheel
- SWCP-LF** Spare wheel carrier on left side in front of rear axle
- SWCP-T** Temporary spare wheel carrier.
- SWCP-TP** Spare wheel is transport mounted (strapped on top of the frame rails) with plastic stripes.
- SWCP-TP** Spare wheel carrier transport mounted with the spare wheel on top of the frame rails
- JACK-12T** Jack 12 tonnes
- JACK-15T** Jack 15 tonnes
- JACK-20T** Jack 20 tonnes
- TOOL-BAS** Basic tools (combination screw driver, socket wrench)
- TOOLKIT** Extended tool kit
- INFLAHOS** Tyre inflation hose (18 metres) with nozzles in both ends
- GAUGE-TP** Tyre pressure gauge
- OBDEP-C** EU6 mandatory on board diagnostics, phase C regulations
- OBDEP-D** EU6 mandatory on board diagnostics, phase D regulations
- Powertrain equipment**
- ASO-C** One crawler gear
- ASO-ULC** Two crawler gears, one ultra low crawler and one crawler
- TRAP-HD** Reinforced gearbox application.
For manual gearboxes a heavy-duty nodular iron range housing.
For I-shift gearboxes (2412 excl.) a reinforced gear shifting system.
- TP-BAS** I-shift City gear changing software
- TP-CON** I-shift construction gear changing software
- TP-DIST** I-shift distribution gear changing software
- TP-HD** I-shift Heavy Duty gear changing software
- TP-LONG** I-shift long haul gear changing software
- AMSO-AUT** I-shift manual gear shift available in automatic mode incl kickdown function
- AVO-ENH** Enhanced I-shift software for construction and off road applications
- APF-ENH** Enhanced I-shift PTO functions (Auto Neutral / Reverse Inhibit / Split Box Connection)
- CD43-O** Dual plate clutch, plate diameter 430 mm
- TC-MAOH2** Extra high performance cooler for manual/I-shift gearboxes - air/oil
- TC-MWO** Basic performance cooler for manual/I-Shift gearboxes - water/oil
- TC-MWOH2** High performance cooler for manual/I-Shift gearboxes - water/oil
- 2COM1100** Dual cylinder air compressor 760 cc / 1100 l/min
- 2COMP900** Dual cylinder air compressor 636 cc
- CLU-AIRC** Air compressor clutch automatically declutched when not needed in order to save fuel
- AIRIN-HI** High air intake
- AIRIN-LO** Low air intake
- ACL1ST-S** Air cleaner with additional filter element (primary + secondary)
- 24AL110B** Alternator 110 Ampere
- 24AL120B** Alternator 120 Ampere
- 24AL150B** Alternator 150 Ampere
- CCV-C** Closed crankcase ventilation
- PRIM-EL** Electrical priming pump for fast and easy bleeding of the fuel system
- PRIM-MAN** Manual priming pump for fast and easy bleeding of the fuel system
- AF-R** Hot fuel recirculation heated fuel filter
- EST-AID** Engine start pre-heating element
- 220EBH15** Engine block heater, 220 volt, 1.5 kW
- PTER-DIN** Rear engine mounted clutch independent PTO with splined shaft groove (female) for a close coupled pump (DIN 5462 / ISO 7653)
- HPE-V45** Rear engine mounted hydraulic pump VP1-45, variable displacement, single flow
- HPE-V75** Rear engine mounted hydraulic pump VP1-75, variable displacement, single flow
- PTR-D** Mechanical gearbox driven low speed power take-off, 1 rear connection (DIN 5462 / ISO 7653) for plug-in pump (max. 1000 Nm).
- PTR-DH** Mechanical gearbox driven high speed power take-off, 1 rear connection (DIN 5462 / ISO 7653) for plug-in pump (max. 600 Nm).
- PTR-DM** Mechanical gearbox driven medium speed power take-off, 1 rear connection (DIN 5462 / ISO 7653) for plug-in pump (max. 600 Nm).
- PTR-F** Mechanical gearbox driven low speed power take-off, 1 rear flange connection (SAE 1410 / ISO 7647) for propeller shaft (max. 1000 Nm).
- PTRD-D** Mechanical gearbox driven high speed power take-off, 1 rear and 1 front connections (DIN 5462 / ISO 7653) for plug-in pumps (max. 870 Nm).
- PTRD-F** Mechanical gearbox driven high speed power take-off, 1 rear flange connection (SAE 1410 / ISO 7647) for propeller shaft (max. 870 Nm).
- HPG-F101** Gearbox mounted hydraulic pump F1-101, fixed displacement, single flow
- HPG-F41** Gearbox mounted hydraulic pump F1-41, fixed displacement, single flow
- HPG-F51** Gearbox mounted hydraulic pump F1-51, fixed displacement, single flow
- HPG-F61** Gearbox mounted hydraulic pump F1-61, fixed displacement, single flow
- HPG-F81** Gearbox mounted hydraulic pump F1-81, fixed displacement, single flow
- EIDLES** Engine idle shut down
- Cab Interior, Driving**
- STWPOS-L** Left hand drive
- STWM-LE** Leather steering wheel
- STGW-AD2** Mechanically adjustable steering wheel with neck tilt
- STGW-ADJ** Mechanically adjustable steering wheel
- AIRBAG** Airbag on driver side
- INST-BAS** Basic level instrument cluster - 4 inch monochrome display 240x320 pix
- DRC-AMII** Regeneration control of diesel filter particulates - auto initiation / manual on demand / manual inhibition
- 1DAYDIG** One day digital tachograph, EC approved
- 1DAYDIG2** Gen 2 one day digital tachograph, EC approved
- 1DAYDIGP** One day digital tachograph, EC approved + Prep Kit for TAS-DIG2
- ARSL** Additional road speed limiter (switch in dashboard)

■ Standard Equipment

□ Optional Equipment

For more detailed information about cab and powertrain equipment, please refer to separate specification sheets.

For all possible options and combinations of options please consult your Volvo sales contact who can create a specification to match your requirements using the Volvo Sales Support system (VSS).

The factory reserves the right to modify design and change equipment without previous notification. The specification can vary from country to country.

MODEL RANGE

FMX D13 104 RIGID FAA20, TRIDEM FM104FTR3HAX

- CRUIS-E** Cruise control I-Cruise with controls in the steering wheel, I-Roll incl. Adding PVT-EXT-MAP give I-See.
 - **CRUISEC** Basic cruise control with controls in steering wheel
 - ESP-BAS1** Electronic Stability Program package intended for RIGID single vehicles or vehicle combinations with standard centre of gravity height when laden and for TRACTOR vehicle combinations with a single trailer or multiple trailers with ABS/EBS.
 - ESPC-RO** ESP (Electronic Stability Program) functionality control - Reduced / Off
 - HWSS-AC** Adaptive cruise control with forward collision warning
 - HWSS-ACB** Adaptive cruise control with forward collision warning (stationary and moving objects) and emergency braking. Using both radar and camera to collect info.
 - HWSS-FCB** Forward collision warning (stationary and moving objects) with emergency braking
 - LSS-DW** Lane keeping support - lane departure warning system
 - LCS** Lane Change Support
 - DAS-W** Driver Alert Support (drowsy driver warning)
 - RSENS-W** Wiper rain sensor
 - CU-ECC** Fully electrically controlled air conditioning with sun sensor
 - CU-ECC2** Fully electrically controlled air conditioning with sun sensor, mist sensor, air quality sensor and carbon filter
 - **CU-MCC** Electrical manually controlled air conditioning
 - **IMMOBIL** Immobiliser
 - ALARM-B** Burglar alarm - cab
 - ALARM-E** Burglar alarm - cab/body/trailer
 - ALCOLOCK** Alcolock
 - BUPMON** Back-up monitor including a 7 inch colour display integrated in dashboard, Waeco CCD-camera (delivered loose in cab) with a heated lens, motorised lens protection, 1 m pigtail cable (front) and 10 metres chassis cable for tractor /20 metres for rigid. Camera wirings not installed. Use PCA30081 for installation.
 - PHONE-PK** Telephone preparation kit (antenna, antenna attachment, cable from antenna to radio shelf).
 - WLIFT-AD** Electrical window lift, auto up/down driver side; el operated on passenger side
 - **WLIFT-EB** Electrical window lift. From the driver side both windows can be operated and from the passenger side the passenger side window can be operated.
 - ISUNS-BS** Manually manoeuvred side interior sun visor (roller blind type) on both sides
 - **ISUNS-DS** Manually manoeuvred side interior sun visor (roller blind type) on driver side
 - **ISUNF-B** Interior front plastic sun visors (driver and passenger side) without mirror on driver side
 - ISUNF-MD** Interior front plastic sun visors (driver and passenger side) with mirror on driver side
 - ISUNF-RE** Electrical textile interior sun visor (roller blind) integrated in front shelf
 - ISUNF-RM** Manual interior textile sun visor (roller-blind) integrated in front shelf
 - **CSPU-S** One open storage (behind push open lid) in upper part of dash panel center section
 - ADFS** Two extra DIN slots in front shelf (push/pull storage), 165x40x180 mm (WxHxD)
 - BUPALARM** Back-up alarm
 - RTOLL-PK** Preparation kit for road toll collect (GPS/GSM antenna and cables)
 - LOADIND** Load indicator with dashboard display. Measures axle pressures, load weight and total weight of truck
 - **Standard Equipment** **Optional Equipment**
- REMC-MF** Wireless remote control - multi functional
 - FIREXT2G** Fire extinguisher 2 kg, German decal
 - FIREXT3S** Fire extinguisher 3 kg, Swedish/English decal
 - WARNEST** Warning vest. Fulfills European standard according to EN 471 class 2.
 - **WARNTRI2** Two warning triangles
 - AIDKIT** First aid kit containing sticking plaster, washing and drying pads, compresses, elastic bandages, respiratory mask, gloves and scissors
 - AIDKIT1B** First aid kit containing sticking plaster, compresses, elastic bandages, gloves, scissors, triangular bandage, bandaging cloths, adhesive tape and rescue sheet (German requirements)
 - WARNLAMP** Portable warning lamp with batteries
 - LAMP-IN** Inspection lamp with 10 m cable
 - BULBKIT** Bulb and fuse kit
 - WRITEPAD** Writing pad with spring-loaded paper clip
- ### Cab Interior, Living
- UPHTRI10** Seat upholstery with black embossed textile insert, black vinyl bolster and blue vinyl side insert & textile interior trim in matching grey/blue nuances
 - **UPHTRI11** Seat upholstery with light grey embossed textile insert, raven metallic vinyl bolster and red vinyl side insert & vinyl/textile interior trim in matching skylark/grey/black nuances
 - UPHTRI12** Seat upholstery with blue soft textile insert, black vinyl bolster & textile interior trim in matching grey/black/blue colours
 - UPHTRI13** Seat upholstery with dark grey leather insert and black leather bolster & vinyl/textile interior trim in matching grey/black nuances
 - UPHTRI14** Seat with dark grey leather insert and black leather bolster & textile interior trim in matching grey and black colours
 - **DST-CF1** Driver seat, comfort, suspended
 - DST-CF4** Driver seat, comfort, suspended, belt in seat
 - DST-CF5** Driver seat, comfort, suspended, belt in seat, electrically heated
 - DST-CF6** Driver seat, comfort, suspended, belt in seat, electrically heated, ventilated
 - SBD-RED** Red safety belts, passenger and driver seats
 - SBPRE-DS** Driver seat belt pretensioner
 - PST-BAS1** Passenger seat, basic, non suspended
 - PST-BENC** Bench passenger seat
 - PST-CF4** Passenger seat, comfort, suspended, belt in seat
 - PST-CF5** Passenger seat, comfort, suspended, belt in seat, electrically heated
 - **PST-STD2** Passenger seat, regular, non suspended
 - PST-STD4** Passenger seat, regular, suspended
 - SBPRE-PS** Passenger seat belt pretensioner
 - ARM-DBPS** Two armrests on driver seat and one (outer) on passenger seat
 - ARMRE-BB** Two armrests on both driver and passenger seats
 - ARMRE-DB** Two armrests on driver seat
 - ARMRE-PB** Two armrests on passenger seat
 - ARMRE-PS** Single armrest (next to driver) on passenger seat
 - ARU-BAS** Vinyl armrest upholstery
 - ARU-LEA** Leather armrest upholstery
 - **GRABHI-B** Steel instep grab handle
 - **FMAT-RU2** Two black rubber floor mats with raised edges and an extended side (FMX)
 - FMAT-RUB** Two black rubber floor mats
 - FMAT-T2E** Two dark grey textile floor mats and two black rubber floor mats with an extended side (FMX)
 - FMAT-TX2** Two textile (dark grey on FH/FM, black on FH16) and two black rubber floor mats

For more detailed information about cab and powertrain equipment, please refer to separate specification sheets.

For all possible options and combinations of options please consult your Volvo sales contact who can create a specification to match your requirements using the Volvo Sales Support system (VSS).

The factory reserves the right to modify design and change equipment without previous notification. The specification can vary from country to country.

MODEL RANGE

FMX D13 104 RIGID FAA20, TRIDEM FM104FTR3HAX

- LBK-RES** Lower fixed rest kit, foldable to rear wall
- LBK70** Lower fixed bunk, not foldable - 2000x700 mm. Safety net included.
- **ULBK** Without lower bunk
- MATL-FI** Mattress lower bunk - firm for over approx. 100 kg, pocket springs.
- MATL-SF** Mattress lower bunk - semi-firm up to approx 100 kg, pocket springs.
- OLMAT-BA** Overlay mattress protector, 28 mm thick black textile
- OLMAT-PR** Overlay mattress protector, 35 mm thick black textile
- TBK60F** Fixed top bunk 600x1900 mm, foldable up to 52 degrees to rear wall (depending on cab version and upper storage). Safety net included.
- TBK70F** Fixed top bunk 700x1900 mm, foldable up to 52 degrees to rear wall (depending on cab version and upper storage). Safety net included.
- PH-CAB2** Cab parking heater, 2 kW
- PH-ENGCA** Engine and cab parking heater
- PH-SS** Short stop heater
- SLCP-BAS** Basic sleeper control panel (controlling interior light, parking heater, roof hatch and door lock)
- SAFE** Key operated safe box under bed (FH) or at bed end (FM)
- ETSB-F** Storage on engine tunnel - on front top
- ETSB-FR** Storage on engine tunnel - on front top and at rear cab wall
- ETSB-FRS** Storage on engine tunnel - on front top & at rear cab wall & storage immersed into tunnel on RH side
- ETSB-FS** Storage on engine tunnel - on front top and storage immersed into tunnel on right hand side
- ETSB-R** Fixed engine tunnel storage box at rear cab wall
- ETSB-RS** Storage on engine tunnel - at rear cab wall and storage immersed into tunnel on right hand side
- ETSB-S** Storage on engine tunnel - immersed into tunnel on right hand side
- RUS-BAS** Rear cab upper storage 154 litres (300 mm high)
- RUS-HIG** Rear cab upper storage 245 litres (440 mm high)
- TABLE** Foldable and height adjustable table to be mounted to the lower bunk
- REF-ICPK** Refrigerator preparation kit, engine tunnel mounted
- REFR-RUS** 28 litre rear upper wall mounted refrigerator with dividers
- MICRO-PK** Preparation kit for microwave oven (el. cables to front shelf)
- BOTH-D** One 1.5 litre plastic soft-drink bottle holder under dashboard centre section
- COFMA-PK** Preparation kit (24V) for coffee maker
- **INLI-BAS** Interior white light with smooth light transition at on/off, no dimming
- INLI-NL** Interior white and red (night) light with smooth light transition at on/off
- INLI-NLD** Interior white and red (night) light with smooth light transition at on/off and dimmer
- ARL-FLEX** Two (driver and passenger side) reading lamps with flexible arms (snake lamps) and led lamps fitted on side walls
- RH-MSR** Roof hatch - Manually operated / Steel / Rear opening
- **URH** Without roof hatch
- SWIND-BS** Extra side window on both sides
- SWIND-PS** Rear side window on passenger side
- VANMIR** Vanity mirror in front shelf lid. In sleeper cab on passenger side and in high/extra high cabs in middle section of the front shelf.
- AS-FUS** One extra shelf in each of the two front upper storage compartments. Only 1 shelf if microwave oven mounted in one of the two compartments.
- INFOT-PK** Preparation kit (bracket, security straps, power cable, antenna

■ Standard Equipment

Optional Equipment

For more detailed information about cab and powertrain equipment, please refer to separate specification sheets.

For all possible options and combinations of options please consult your Volvo sales contact who can create a specification to match your requirements using the Volvo Sales Support system (VSS).

The factory reserves the right to modify design and change equipment without previous notification. The specification can vary from country to country.

cable and aux cable) for mounting of a television above driver door.

Cab Exterior

- **PAICS-B** Basic painting in a lightning grey colour of cab surrounding parts (mirror housings, insteps, bumper and if fitted bumper spoiler and sun visor). If fitted roof air deflector, side air deflector and chassis fairings are always painted in cab colour.
- **GLAS-TIN** Tinted windows (front/side/rear)
- AWIND-RF** Rear fixed window (without curtains)
- DGLAS-L** Laminated door glass
- **LOCK-MAN** Manual door locking
- LOCK-MRP** Manual door locking with internal remote control (from driver side) of passenger door
- LOCK-REM** Central door locking with remote control
- **BUMP-HD** Heavy duty front bumper
- AUXFS** Extra cab side foot-step
- GUARD-EH** Guard plate for cooling pipes and oil sump
- SIDEH-B** Guide rail on day cab driver side
- SIDSTP-R** Side ladder and guide rail on on day cab driver side
- **BUGNET** Radiator screen / Mosquito net (PVC coated fibreglass) in front of radiator
- CTILT-P-E** Electrical cab tilt pump
- **CTILT-P-M** Manual cab tilt pump
- FCABS-A** Air front cab suspension
- **FCABS-M** Mechanical cab suspension
- RCABS-A** Air rear cab suspension
- **RCABS-M** Mechanical rear cab suspension
- MIRCOMFX** EI heated & operated robust main rear view mirrors, electrically heated wide angle mirrors (both sides). Close view mirror on passenger side.
- **MIRSTDX** Electrically heated robust main rear view mirrors and wide angle mirrors (both sides). Close view mirror on passenger side.
- **AMIR-F20** Front close view mirror above windscreen, passenger side (radius 200 mm)
- SUNV-H** Exterior transparent dark grey front sun visor
- AD-ROOF** Roof air deflector. Design (length, height etc.) automatically calculated and varies depending on vehicle total height (chassis height, cab type, tyres etc).
- AD-SIDEL** Long cab side air deflector
- AD-SIDES** Short cab side air deflectors
- **HL-BAS2** Halogen H1 head lamps (heavy duty)
- HL-BASIC** Halogen H7 head lamps
- HL-BHID2** Bi-Xenon head lamps, high intensity discharged (heavy duty)
- HL-CLEAN** High pressure headlamp cleaner
- HLP-ST** Steel headlamp protection
- HL-ADJ** Adjustable headlamps to adjust the height of the light beam
- **DRL-LED** V-shaped ("V-light") day running light (LED). Turned on low beam gives a dimmed "V-light".
- **UDRIVL** Without auxiliary front driving lamps
- ASL-RF2** Two Hella H11 70W spot lamps in sign box (one on each side of the Globetrotter sign)
- ASL-RFPK** Preparation kit for two spot lamps in sign box
- BEACO2F** Two front roof mounted amber rotating beacon warning lamps. Mounted on accessory bracket if ordered, otherwise on cab roof on both sides of the hatch.
- BEACO2R** Two rear roof mounted (on accessory bracket) amber warning lamps. Rotating beacon lamps mounted on sleeper cab.

MODEL RANGE

FMX D13 104 RIGID FAA20, TRIDEM FM104FTR3HAX

- **BEACON-P** Flashing LED lamps mounted on high/extra high sleeper cabs. Prepared wiring (switch and connected relay included) for warning lamps on cab roof. Max load 300 W.
 - **BEACONA4** Four roof mounted amber warning lamps. 2 front mounted (on accessory bracket if ordered) rotating beacon lamps. 2 rear mounted (on mandatory accessory bracket) rotating beacon lamps on sleeper cab. 2 rear mounted (on mandatory accessory bracket) flashing LED lamps on high/high sleeper cabs.
 - **CABPT-R1** One front cab roof pass through on passenger side
 - **CABPT-R2** Two front cab roof pass throughs, one on each side
 - **SPOTP-F** Spotlamp preparation in cab front, max 280W
 - **SPOTP-R** Spotlamp preparation on cab roof, max 280W
 - **SPOTP-RF** Spotlamp preparation on cab roof and in cab front, max 2x280W
 - **ROS-IL** Illuminated roof sign with switch in radio shelf. Switch for turning on/off.
 - **ROS-IL2** Preparation kit for installing an illuminated roof sign*. It includes a prerouted cable harness, a switch and LED-lamps. The switch is connected in the radio shelf middle section. Switch cap with icon, are enclosed in cab. Lamps in sign are mounted. The stripe in the Globetrotter window is selected via the cab sign variants
 - **ROS-ILP** Wiring preparation kit (wires and switch) for cab sign or roof air deflector illumination
 - **CSGN-FMX** FMX decal in the cab roof sign area
 - **HORN-F1S** One front mounted (behind grille) single tone air horn, Jericho. Operated by steering wheel buttons.
 - **HORN-R2S** Two roof mounted single tone chromed air horns. Operated by steering wheel buttons.
 - **ANT-CBR** Right hand side roof mounted foldable antenna and cables for CB radio, single aerial.
 - **ACCBR-AP** Front, middle & rear roof mounted accessory brackets
 - **ACCBR-F** Front roof mounted accessory bracket
 - **ACCBR-FM** Front & middle roof mounted accessory brackets
 - **ACCBR-FR** Front & rear roof mounted accessory brackets
 - **ACCBR-M** Middle roof mounted accessory bracket
 - **ACCBR-R** Rear roof mounted accessory bracket
 - **ACCBR-RM** Rear & middle roof mounted accessory brackets
 - **REFS-TW** Reflecting white cab side stripes by-packed in cab
 - **REFS-TY** Reflecting yellow cab side stripes by-packed in cab
- Superstructure preparations**
- **SRWL-PK** Wiring preparation for chassis mounted working lamps and a 3-position switch (On/Off/Reverse auto on). Max load 280W.
 - **SWL-2FW** Two H3 70W white front chassis mounted (LH/RH side) working lamps and a 2-position switch (On/Off)
 - **SWL-2RW** Two H3 70W white rear chassis mounted (LH/RH side) working lamps and a 2-position switch (On/Off)
 - **SWL-4W** Four H3 70W white front (2) and rear (2) chassis mounted (LH/RH side) working lamps and a 2-position switch (On/Off)
 - **SWL-PK** Wiring preparation for chassis mounted working lamps and a 2-position switch (On/Off). Max load 280W.
 - **WL-CHPK** Preparation kit (switch and cable) for working lamp, max 2x70 W. Connector on chassis at gearbox.
 - **WLC-H2A** Two H3/70W working lamps with amber coloured lens high mounted back of cab (switch incl).
 - **WLC-H2W** Two H3/70W working lamps, white lens high mounted back of cab (switch incl).
 - **WLC-PKCH** Preparation kit (cables and switch) for cab mounted chassis working lamp. Max load 280W.
 - **WLC-PKH** Preparation kit (cables and switch) for high mounted working lamps back of cab (pass through in cab rear roof included). Max load 280W.
 - **WLC-PKL** Preparation kit (cables and switch) for low mounted working lamps back of cab (pass through in cab rear wall included). Max load 280W.
 - **WLC-PKLH** Preparation kit (cables and switch) for low and high mounted working lamps back of cab (pass throughs in rear wall and rear roof included). Max load 280W.
 - **ECBB-BAS** Body builder electrical centre without any body builder module
 - **ECBB-HIG** Body builder electrical centre with cab body builder module
 - **BBCHAS1** One 7-pole connector for Body builder interface. Wiring harness routed from the bodybuilder electrical distribution box inside the cab to a connection point inside the right frame rail beside the gearbox.
 - **BBCHAS3** Three 7-pole connectors for Body builder interface. Wiring harness routed from the bodybuilder electrical distribution box inside the cab to a connection point inside the right frame rail beside the gearbox.
 - **BEPR-T2** Body builder electrical software preparation for tipper with remote control
 - **EXSTER** Support for external steering control via body builder module
 - **TD-BAS** Trailer detection without LED sensor
 - **TD-LED** Trailer detection with LED sensor
 - **FRFS-BS** Frame rail free space on both sides to give space for crane legs or other equipment. One front axle with day cab: 515/507 mm (L/R side). One front axle with long cab: 288/360 mm (L/R side). Two front axles with short cab: 632/572 mm (L/R side). Two front axles with long cab: 405/485 mm (L/R side).
 - **FBA-BTF** Lower front body attachments for torsionally flexible platform body
 - **FBA-BTSF** Lower front body attachments for torsionally semi-flexible body (van or curtainsider)
 - **HBA-FSFB** Holes for body attachments, flexible/semi-flexible body
 - **HBA-SB** Holes for body attachments, stiff body
 - **RBA-T2** Lower rear body attachments for helper frame
 - **CRANEPK1** Crane plates mounted to frame, interface for crane capacity up to 10 ton meter
 - **CRANEPK2** Crane plates mounted to frame, interface for crane capacity up to 20 ton meter
 - **CRANEPK4** Crane plates mounted to frame, interface for crane capacity up to 40 ton meter
 - **AUXL-SPK** Electrical preparation kit (wiring and a switch in dashboard) for snow plough lights. Preparation for installation of additional headlights and additional turning indicators.
 - **TAILPRE2** Tail lift preparation kit, wireless remote operation
 - **TAILPREP** Tail lift preparation kit, wire remote operation
 - **AESW2** Two Body builder bistable electrical switches (marked AUX1 / AUX2)
 - **AESW2PK** Two Body builder bistable electrical switches (marked AUX1/AUX2) and in an empty 4-group preparation another four bistable switches with dummy switch caps
 - **AUXSW-4** Wiring for 4 extra hardwired switches (from Body builder electrical centre to switch positions)
- Services**
- **TGW-4GWL** Telematics gateway with 4G modem
 - **FMS-PK** Fleet Management System gateway, preparation kit
 - **DRUT** My truck app gives the driver instant status information and control of the vehicle remotely from a smartphone or tablet. The variant enables the My truck app to connect to the vehicle.

VOLVO

Volvo Truck Corporation

volvotrucks.com