

MODEL RANGE

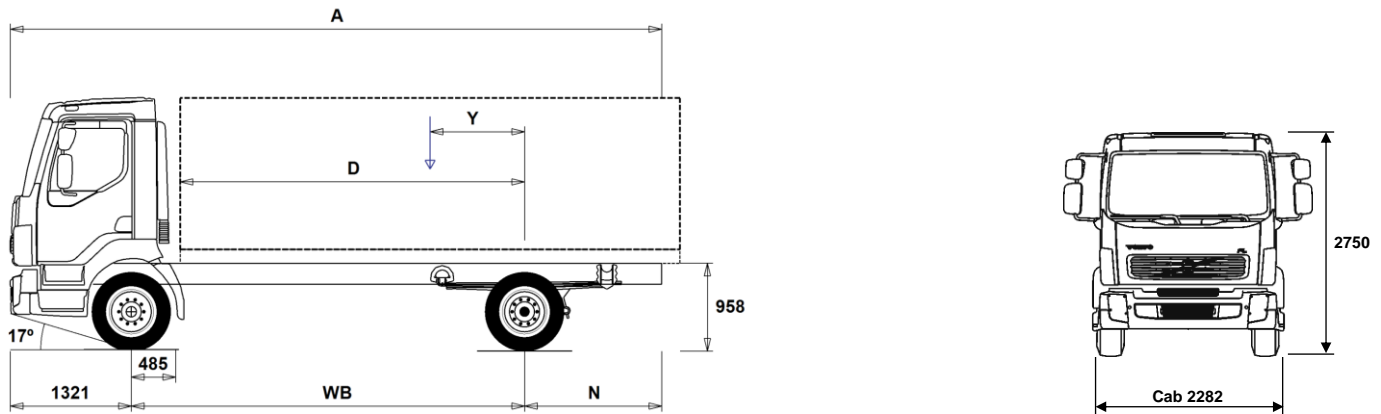

Volvo Trucks. Driving Progress

FL L 12tonne 4x2 Rigid Steel 19.5"- OLD MODEL FLL42 RD 12L



Chassis Dimensions [mm]

WB Wheelbase	3070	3250	3500	3800	4100	4400	4700	5000	5300	5600	5900	6200	6500
A Overall Chassis Length	6216	6546	6976	7426	7956	8426	8856	9436	9916	10426	10936	11431	11731
D Center of rear axle to front of body	2535	2715	2965	3265	3565	3865	4165	4465	4765	5065	5365	5665	5965
N Rear Overhang (Min.)	1775	1885	2055	2245	2445	2635	3025	3225	3415	3615	3795	3755	3755
N Rear Overhang (Max.)	1825	1975	2155	2305	2535	2705	2835	3115	3295	3505	3715	3910	3910
Y Center of Gravity for Payload (Min.)	143	149	160	172	187	201	216	225	238	247	259	271	284
Y Center of Gravity for Payload (Max.)	753	796	857	931	1012	1078	1163	1227	1318	1384	1470	1547	1621

Chassis Weights [kg]

Front Axle	3150	3155	3155	3160	3160	3155	3155	3165	3170	3175	3180	3180	3180
Rear Axle	1310	1315	1320	1325	1385	1315	1395	1350	1470	1440	1515	1530	1525
Kerb Weight	4460	4470	4475	4485	4545	4470	4550	4515	4640	4615	4695	4710	4705
Payload (including body, driver, fuel, etc.)	7540	7530	7525	7515	7455	7530	7450	7485	7360	7385	7305	7290	7295

Turning Diameter [mm]

Turning Circle Diameter Kerb to Kerb	11100	11600	12400	13300	14200	15100	16000	16900	17800	18700	19600	20500	21400
Turning Circle Diameter Wall to Wall	12400	12900	13700	14600	15500	16400	17300	18200	19100	20000	20900	21800	22700

Plated Weights [kg]

	Plated	Design
Gross Vehicle Weight	12000	12000
Gross Combination Weight	40000	
Front Axle	5000	5000
Rear Axle	8500	8500

Important Notes

Chassis Dimensions

Cab Height: +3 mm for L2H1.

Front Axle to Back of Cab: +331 mm for L2H1.

D-measure includes a front clearance of 50 mm and for rigid trucks also a subframe of 120 mm.

Height can vary ± 20 mm for leaf and ± 10 mm for air suspension.

All dimensions are for unladen chassis and any tag axles down.

Rear overhang used for vehicle weight calculation is the maximum rear overhang (N Max.) for selected wheelbase.

Weight and dimensions are based upon the following tyres:

Front Axle Tyres: 265/70R19.5

Drive Axle Tyres: 265/70R19.5

Chassis weight includes oil, water, AdBlue, 70 litres fuel and without driver. Kerb weight can vary ± 1.5%.

Turning diameters are theoretically calculated.

Legal weights can differ from country to country.

For more detailed weight information, including optional equipment weights, ask your Volvo sales contact to enter your specification into the Volvo Weight Information system (WIS).

Do NOT use this drawing for bodybuilding. Refer to Volvo Bodybuilder Instructions and chassis assembly drawing 20824851, 20824853.

MODEL RANGE

FL L 12tonne 4x2 Rigid Steel 19.5"- OLD MODEL FLL42 RD 12L

CORE COMPONENTS

- ENGPROT** Engine protection
- **L1H1** Short day cab - with steel safety cage design
Designed and built to Swedish impact and ECE R29 regulations
- L2H1** Medium cab - with steel safety cage design
Designed and built to Swedish impact and ECE R29 regulations
- EU4SCR** Euro 4 SCR Selective Catalytic reduction
- EU5EEV** Euro 5 EEV Enhanced Environmental Vehicle
- **EU5SCR-M** Euro 5 Mandatory engine emission level.
- D7E240** D7E240 7.2l engine developing 240hp
Max torque 920Nm at 1200-1700rpm.
- D7E280** D7E280 7.2l engine developing 280hp
Max torque 1050Nm at 1200-1700rpm.
- **D7F240** D7F240 7.2l engine developing 240hp
Max torque 940Nm at 1200-1800rpm.
- D7F260** D7F260 7.2l engine developing 260hp
Max torque 1010Nm at 1200-1800rpm.
- D7F290** D7F290 7.2l engine developing 290hp
Max torque 1070Nm at 1200-1800rpm.
- EBR-CBJ3** Engine brake producing 188kW at 2800rpm
controlled by steering column switch
- **EBR-EPG** Exhaust brake producing 130kW at 2800rpm
controlled by steering column switch
- AL306** Allison AL306 6-speed automatic gearbox
(If a PTO is required it must be specified from the factory)
- ATO1056** ATO1056 6-speed overdrive "I Sync" automated mechanical gearbox
- **ZTO1006** ZTO1006 6-speed overdrive gearbox
- ZTO1109** ZTO1109 9-speed range change overdrive gearbox
- **CS39A-O** Single plate 395mm (16") clutch
- **FAL5.0** Front axle design capacity 5.0 tonnes
- **FST-PAR** Parabolic front springs with shock absorbers and anti roll bar
- FST-PAR3** Stiff parabolic front springs with shock absorbers and anti roll bar
- **RAD-L80** 80mm parabolic rear springs
- **RSS1125A** RS1125A single reduction rear axle - design GCW 25tonne
with differential lock
- RSS1132A** RS1132A single reduction rear axle - design GCW 32tonne
with differential lock
- **RAL8.5** Rear axle design capacity 8.5 tonnes
- **RST-PAR3** Stiffer parabolic rear springs
- **RSTAB1** Rear anti-roll bar

Packages

- DAY1** FL day cab
- MEDIUM2P** FL Medium cab with 3 person Seating and Storage
- MEDIUM3P** FL Medium cab with 3 person Seating and Storage
- REST1** FL Medium cab with 580mm Occasional rest bunk
- REST2** FL Medium cab with 780mm Fold down bunk
- AUDIODAB**
- **AUDIOPD**

TRUCK USE

- LTRW1** Legal trailer weight up to 10tonnes
- LTRW2** Legal trailer weight more than 10tonnes
- ADR2** ADR package for transportation of dangerous goods on road
(Note does NOT include safe loading pass package if required this is quoted separately)
- STWPOS-L** Left hand drive
- **STWPOS-R** Right hand drive

CHASSIS

- **BRAKE-DV** Ventilated disc brakes

- EBS-MED** EBS+ package including traction control & hill hold
- **EBS-STD** EBS standard package without traction control
- **FRAME55** Frame thickness 5mm
- FRAME66** Frame thickness 6mm
- FRAME77** Frame thickness 7mm
- **FRAME220** Frame section height 220mm (measured internally)
- **FMAT-BAS** Frame material steel - basic
- FMAT-HT** Frame material high tensile steel
- FRACLOS** Frame end closing
- **2BATT170** 2 x 170 Ah capacity batteries on left hand side
- EXD-LEFT** Horizontal silencer - catalyst, with left exhaust outlet
- **EXD-REAR** Horizontal silencer - catalyst, with rear exhaust outlet
- EXD-VERL** Horizontal silencer - catalyst, with vertical exhaust outlet
- **R200P** 200 litre right hand plastic fuel tank
Min volume 130l
Max volume 300l
- **UL-FUEL** Without left fuel tank
Min volume 130l
Max volume 130l
- XTR200ST** Right extra fuel tank, 200 litre, steel
- **ADTR20** 20 litre plastic AdBlue tank on right hand side
- ADTR50** 50 litre plastic AdBlue tank on right hand side
- ADTL20** 20 litre plastic AdBlue tank on left hand side
- SWCP-LF** Spare wheel carrier on left side, in front of rear axle.
- SWCP-R** Spare wheel carrier rear mounted below frame.
- SWCP-RF** Spare wheel carrier in front of rear axle on right side.
- SWCP-T** Spare wheel supplied temporarily strapped to chassis
- SWCP-TP** Spare wheel carrier transport mounted on frame (spare wheel carrier not included)
- WHC-FIX1** One wheel chock
- WHC-FIX2** Two wheel chocks
- FRAHO-RO** Series of frame holes drilled in the last 1.6m of the rear overhang for taillift mounting
- C-RO40AG** Rockinger 400 G145
- TOWR-ONE** Pintle type towing hitch attached to rear crossmember for 3.5tonne trailer
- RUP-FIS** Fixed EC approved steel C section rear underrun with integrated rear lights
- RFEND-T** Mudwings on drive axle for transportation only
- **TOWF-NO1** One towing device in front.
- TOWF-NO2** Two towing devices in front.

WHEELS & TYRES

- SPWT-F** Spare wheel & tyre with front tyre pattern

DRIVELINE EQUIPMENT

- RET-TPT** Retarder for automatic gearbox
- 1COMP225** Single cylinder, 225cc air compressor, 133 litres per minute @1000rpm
- **2COMP720** Two cylinder, 720cc air compressor, 420 litres per minute @1000rpm
- APUL1** Additional V-belt crankshaft pulley for additional compressor/alternator etc.
- APUL2** Additional poly-V belt crankshaft pulley for additional compressor/alternator etc.
- **AIRIN-HI** High air intake behind cab on right hand side
- ACL2ST** Air cleaner with extra filter element
- 24AL120B** 120 amp alternator
- **24ALT-XB** 100 amp alternator
- ELG-PK** Preparation kit for fridge alternator

- Standard Equipment
- Optional Equipment

For more detailed information about cab and powertrain equipment, please refer to separate specification sheets.

For all possible options and combinations of options please consult your Volvo sales contact who can create a specification to match your requirements using the Volvo Sales Support system (VSS).

The factory reserves the right to modify design and change equipment without previous notification. The specification can vary from country to country.

MODEL RANGE

FL L 12tonne 4x2 Rigid Steel 19.5"- OLD MODEL FLL42 RD 12L

- ENGENV1** Engine working environment -40° to +40°C
 - ENGENV2** Engine working environment -15° to +40°C
 - ENGENV3** Engine working environment -25° to +40°C
 - COOLC40** Cooling capacity 40° C
 - COOLC48** Cooling capacity 48° C
 - AF-E** Auxiliary fuel filter, electrically heated
 - EST-AID** Air inlet manifold starting heater element
 - STHLP** Start help
 - ETC** Electronic throttle control - dash mounted switches that control PTO speed
 - 220EBH08** Engine block heater, 220V/0.8kW
 - PTER-DIN** Rear engine mounted PTO with DIN5462 (female) splined shaft for a close coupled pump
 - PR-HF4S** Live-drive PTO for Allison gearbox output 400Nm for flange connection mounted on the side of the torque convertor
 - PR-HP4S** Live-drive PTO for Allison gearbox output 400Nm for hydraulic pump connection mounted on the side of the torque convertor
 - PTR-FH1** Rear PTO Gearbox S81 flange DIN connection
 - PTR-FH2** Rear PTO Gearbox S84 flange DIN connection
 - PTR-FH5** Rear PTO Gearbox S88 flange DIN connection
 - PTR-PH1** Rear PTO Gearbox S81 pump DIN connection
 - PTR-PH2** Rear PTO Gearbox S84 pump DIN connection
 - PTR-PH4** Rear PTO Gearbox S88 pump DIN connection
 - PTR-PK** Electrical and solenoid prep kit for gearbox PTO
 - PTR-ZF2** Rear Power Take Off flange DIN connection
 - PTR-ZF4** Rear PTO Gearbox 320Nm flange connection
 - PTR-ZF5** Rear PTO Gearbox 320Nm pump connection
 - PTRA-PH2** Add PTO for 9sp box twin S84 pump conn
 - HPG-F101** Gearbox mounted hydraulic pump F1-101, fixed displacement, single flow.
 - HPG-F41** Gearbox mounted hydraulic pump F1-41, fixed displacement, single flow.
 - HPG-F51** Gearbox mounted hydraulic pump F1-51, fixed displacement, single flow.
 - HPG-F61** Gearbox mounted hydraulic pump F1-61, fixed displacement, single flow.
 - HPG-F81** Gearbox mounted hydraulic pump F1-81, fixed displacement, single flow.
- CAB INTERIOR**
- DST-CF5** Driver seat comfort air suspended, heated, with seatbelt built into the seat and adjustments for the following , backrest tilt, height, front tilt, length, adjustable shock absorber and rapid descent.
 - DST-ECO A**
 - DST-STD2**
 - DST-STD8**
 - PST-BAS1**
 - PST-BLUX** Two man passenger bench seat with three point belt in cab and centre seat.
Arm rest on centre seat next too driver.
Fold down backrest on centre seat to form table.
With lockable storage space under the seat
 - PST-ECO A**
 - PST-STD6**
 - PST-STD7**
 - ARMRE-PS** Single armrest on passenger seat next to the driver.
 - BED1858** Occasional single piece foam bunk
Bunk size - Thickness 13.5mm x Width 58cm x Length 180cm
Smoke detector
Front and side window curtains
 - REST1878** Two piece fold up foam bunk
Bunk size - Thickness 9mm x Width 78cm x Length 180cm
Smoke detector
Front and side window curtains
 - UBED** Without bunk
- Standard Equipment □ Optional Equipment
- BEDBAR** Protective bar on the front edge of the bunk
 - ETS-FL** Engine tunnel storebox, adjustable on engine tunnel, features large drawer, bottle holder, pullout table and 12/24v electric sockets.
 - ETS-FLRH** Engine tunnel storebox, adjustable on engine tunnel, features large drawer, bottle holder, lifting top, pullout table and 12/24v electric sockets.
 - ETS-FMR** Engine tunnel storebox, fixed, features two large boxes, rear one with lift of lid, front one with folding flap too form table, front oddmets tray and 24v electric socket.
 - BUNKBOX** Removable open storage bin behind seats
 - FOHS-BAS** Front overhead open storage lockers with nets
 - FOHS-COV** Front overhead storage lockers with doors
 - RWCLOH-H** Clothes rail on rear wall
 - CU-HEAT** Conventional heater unit.
 - CU-MCC** Manually operated air conditioning.
 - PH-CAB** 1.8kW Air to air night heater
 - RH1ELEG** Roof hatch - glass, electrically operated.
 - RH1ELEP** Roof hatch - electrically operated.
 - RH1MANP** Roof hatch - manually operated.
 - URHATCH** Roof hatch - not fitted.
 - WIND-HF** Heated windscreen
 - AWIND-RF** Rear window without curtains.
 - SWIND-PS** Side rear nearside passenger window
 - AWIND-DP** Lower kerb window on passenger door
 - WLIFT-EB** Electric windows both sides
 - WLIFT-ME** Mechanical window lift
 - LOCK-ALL** Central locking with remote control and remote electronic battery master switch.
Note there is no manual master switch on the chassis
 - LOCK-MAN** Manual locking driver and passenger doors.
 - LOCK-REM** Central door locking with remote control.
 - IL-DOOR** White step light in lower door
 - HLA-EL** Electrically adjustable headlights
 - CURT-WIN** Front & side window curtains only.
Note these do not cover the lower door or rear window if specified.
 - CBM-RSH** Aerial connection for CB radio supplied in front overhead shelf
 - ACON-USB** Audio USB connector
 - XCON-AUD** 3.5mm audio mini jack socket
 - AIP-BT** Bluetooth phone capability
 - INST-BAS** Basic instruments & concise driver's information display
Includes - Speedometer, Rev counter, single air pressure & fuel level gauges
 - INST-MED** Medium instruments & driver's information display
Includes - Speedometer & Rev counter
Gauges for fuel level, Oil pressure, Turbo boost, Coolant temperature & individual front and rear air circuits
 - FMS** Fleet Management System gateway
 - DOL12S12** 12 volt dash single outlet
 - DOL24+12**
 - APO24PK** Auxiliary power outlet, 24V in the overhead shelf
 - APNOUTC** Dashboard air connection - for auxiliary items, and inflation hose
 - IMMOAL** Immobiliser and cab alarm
 - IMMOUAL** Immobiliser
 - BUPALARM** Reverse alarm

For more detailed information about cab and powertrain equipment, please refer to separate specification sheets.

For all possible options and combinations of options please consult your Volvo sales contact who can create a specification to match your requirements using the Volvo Sales Support system (VSS).

The factory reserves the right to modify design and change equipment without previous notification. The specification can vary from country to country.

MODEL RANGE

FL L 12tonne 4x2 Rigid Steel 19.5"- OLD MODEL FLL42 RD 12L

- REM-AUD** Remote control for audio system
- FIRE2SWE** 2kg fire extinguisher located by the driver's seat next to the door
- DETECT-S** Smoke detector in cab
- WARNVEST** High visibility warning vest - no sleeves
- WARNTRI1** One warning triangle
- WARNTRI2** Two warning triangles
- AIDKIT** First aid kit - Legal demand for EU markets including delivery to EU bodybuilder
- FLASHL-A** Portable flashing amber lamp
- TACHOP2** Continental VDO DTCO 2.0 digital tachograph for ADR applications can be modified for remote download
- TACHOP4** Continental VDO DTCO 2.0 digital tachograph - can be modified to allow remote download
- CRUISEC** Cruise control with switches in the steering wheel
- JACK-8T** 8 tonne bottle jack
- INFLAHOS** Tyre inflation hose
- GAUGE-TP** Tyre pressure gauge
- MAT-RUB** Rubber Mats
- WRITEPAD** Writing pad - clips on steering wheel when stationary
- STGW-ADJ** Mechanically adjustable steering wheel rake
- STGW-ADP** Pneumatically adjustable steering wheel for height and rake

DELIVERY SERVICES

- LAMP-IN** Inspection lamp

CAB EXTERIOR

- CABS-MEC** Rear cab suspension - coil spring
- MIRCOMF** Electrically heated and operated main mirrors with wide angle mirror on both sides and kerb mirror on the passenger side.
- MIRSTD** Electrically heated main mirrors with wide angle mirror on both sides and kerb mirror on the passenger side.
- CMIR-FF** Close view front mirror
- SUNV-URL** Exterior sunvisor
- AD-ROOF** Fixed cab roof air deflector - not adjustable
- AD-SIDES** Cab side air deflector, short extension panels.
- HL-CLEAN** Head lamp cleaner jet
- HL-ASYML** Head lamp asymmetric, right hand drive
- HL-ASYMR** Head lamp asymmetric, left hand drive
- LOWB-DAY** Day running light
- LOWB-STD** Standard low beam
- FOGL-WB** Fog lights located in the corner of the front bumper
- BEACON-P** Beacon preparation
- BEACONA2** Two amber beacons directly mounted to cab roof
- AHORN-D** Twin roof mounted air horns.
- ACCBR-PK** Accessory roof bracket - preparation kit
- ACCBRKTF** Accessory roof bracket - front

SUPERSTRUCTURE PREPARATIONS

- CRANE-PK** Crane preparation kit - mounting plates for subframe behind cab
Maximum crane capacity on FL L 16tonne/m and FL M 18tonne/m
- TRBRAKE1** Trailer brake valve
- BBP-CF** Body Builder preparation, wiring pass through in cab floor
- ELCE-CK** Electrical interface for Body Builder includes body builder module
- ELCE-PK1** Electrical preparation kit for Body Builder does not include bodybuilder module
- TAILPREP** Taillift preparation kit - cab switch and warning in driver display

VOLVO

Volvo Truck Corporation
volvotrucks.com