

MODEL RANGE

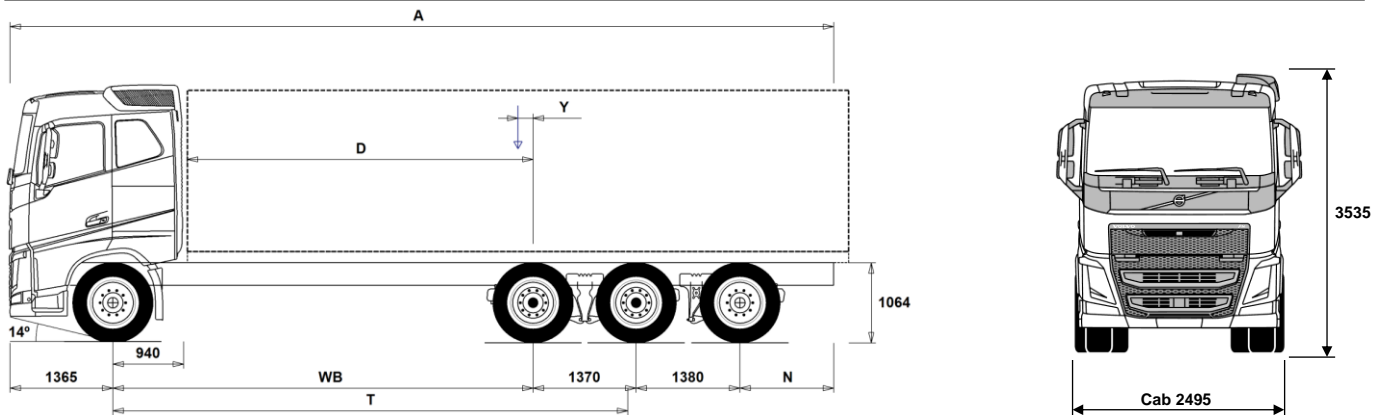

Volvo Trucks. Driving Progress

FH 13 8x4 Rigid - Tag Tridem – contact sales engineering reference application FH 84



Chassis Dimensions [mm]

WB Wheelbase	3700	3900	4100	4300	4600	4900	5200
A Overall Chassis Length	9710	10160	10510	10660	10810	11060	11310
D Center of rear axle to front of body	2710	2910	3110	3310	3610	3910	4210
N Rear Overhang (Min.)	1245	1245	1245	1245	1245	1245	1245
N Rear Overhang (Max.)	1895	2145	2295	2245	2095	2045	1995
T Theoretical Wheelbase	4959	5159	5359	5559	5859	6159	6459
Y Center of Gravity for Payload (Min.)	-568	-541	-514	-491	-457	-423	-388
Y Center of Gravity for Payload (Max.)	-568	-541	-514	-491	-457	-423	-388

Chassis Weights [kg]

Front Axle	4860	4870	4880	4900	4935	4965	4985
Rear Bogie	4695	4720	4750	4745	4725	4745	4735
Kerb Weight	9555	9590	9630	9645	9660	9710	9720
Payload (including body, driver, fuel, etc.)	22445	22410	22370	22355	22340	22290	22280

Turning Diameter [mm]

Turning Circle Diameter Kerb to Kerb	15500	16100	16700	17300	18200	19100	20000
Turning Circle Diameter Wall to Wall	16800	17400	18000	18700	19600	20500	21400

Plated Weights [kg]

	Plated	Design
Gross Vehicle Weight	32000	36000
Gross Combination Weight	44000	44000
Front Axle	8000	9000
Rear Bogie	24000	27000

Important Notes

Chassis Dimensions

Cab Height: +305 mm for CAB-HSLP, -283 mm for CAB-LSLP, +450 mm for CAB-XHSL.

D-measure includes a front clearance of 50 mm and for rigid trucks also a subframe of 100 mm.

Height can vary ± 20 mm for leaf and ± 10 mm for air suspension.

All dimensions are for unladen chassis and any tag axles down. Chassis height used: CHH-HIGH.

Rear overhang used for vehicle weight calculation is the maximum rear overhang (N Max.) for selected wheelbase.

Height change when chassis height CHH-MED,FRAME300: 0 mm.

Weight and dimensions are based upon the following tyres:

Front Axle Tyres:	315/80R22.5
Drive Axle Tyres:	315/80R22.5
Trailing/Pusher Axle Tyres:	315/80R22.5

Chassis weight includes oil, water, AdBlue, 0 litres fuel and without driver. Kerb weight can vary $\pm 3\%$.

Turning diameters are theoretically calculated. Tag axle used: TA-HYDRS.

Legal weights can differ from country to country.

For more detailed weight information, including optional equipment weights, ask your Volvo sales contact to enter your specification into the Volvo Weight Information system (WIS).

Do NOT use this drawing for bodybuilding. Refer to Volvo Bodybuilder Instructions and chassis assembly drawing FH84TR3HA.

MODEL RANGE

FH 13 8x4 Rigid - Tag Tridem – contact sales engineering reference application FH 84

TRUCK USE

- RC-ROUGH** Operating class on/off road
- RC-SMOOT** Operating class highway
- TIPP-PRE** Tipper vehicle preparation
- UNIFORM** Basic platform vehicle

CORE COMPONENTS

- CHH-HIGH** Chassis height high - N3 "On Road" chassis - For a specific loading height always check the unique BEP chassis drawing
- CHH-MED** Chassis height medium - For a specific loading height always check the unique BEP chassis drawing
- TA-HYSBS** Electro-hydraulic steered tag axle, with steering lock out at 38kph
8x2 models with rear steer will use the engine PTO to drive the steering pump, so will need an adapter.
- FH-HSLP** Globetrotter cab - all steel safety cage design with roof mounted emergency escape hatch.
Designed and built to Swedish impact and ECE R29 regulations
- FH-SLP** Sleeper cab - all steel safety cage design with roof mounted emergency escape hatch.
Designed and built to Swedish impact and ECE R29 regulations
- FH-XHSL** Globetrotter XL cab - all steel safety cage design with roof mounted emergency escape hatch.
Designed and built to Swedish impact and ECE R29 regulations
- EU6SCR** Emission level - Euro 6
- D13 420S** D13K420 12.8 litre engine developing 420hp at 14-1800rpm. Peak torque 2100Nm at 860 -1400rpm.
- D13 460S** D13K460 12.8 litre engine developing 460hp at 14-1800rpm. Peak torque 2300Nm at 900-1400rpm.
- D13 460T** D13K460TC 12.8 litre Turbo-compound diesel engine developing 460hp at 14-1800rpm. Peak torque 2600Nm at 900-1250rpm.
- D13 500S** D13K500 12.8l engine developing 500hp at 14-1800rpm. Peak torque 2500Nm at 1000-1400rpm.
- D13 500T** D13K500TC 12.8 litre Turbo-compound diesel engine developing 500hp at 14-1800rpm. Peak torque 2800Nm at 900-1250rpm.
- D13 540S** D13K540 12.8l engine developing 540hp at 14-1800rpm. Peak torque 2600Nm at 1000-1450rpm.
- D13K420** D13K420 - 420hp engine
- D13K460** D13K460 - 460hp engine
- D13K500** D13K500 - 500hp engine
- D13K540** D13K540 - 540hp engine
- EBR-EPG** Exhaust brake controlled by steering column switch
- EBR-EPGC** Exhaust pressure governor for I shift gearbox
- EBR-VEB+** Volvo engine brake + and exhaust pressure governor, enhanced performance from additional exhaust rocker control. Retardation 375kW
- AT2612F** AT2612F 12-speed "I-shift" automated mechanical gearbox suitable for gross train weights up to 60tonne only refer to sales engineering when used in conjunction with a PTO
- AT2812F** AT2812E 12-speed "I-shift" automated mechanical gearbox suitable for gross train weights up to 60 tonne refer to sales engineering when used in conjunction with a PTO
- ATO2612F** ATO2612F 12-speed "I-shift" overdrive automated mechanical gearbox suitable for gross train weights up to 60tonne refer to sales engineering when used in conjunction with a PTO
- ATO3112F** ATO3112F 12-speed "I-shift" overdrive automated mechanical gearbox suitable for gross train weights up to 60tonne refer to sales engineering when used in conjunction with a PTO
- SPO2812** SPO2812 - 12 speed I-shift Dual Clutch automated mechanical gearbox GCW 60tonne

Standard Equipment

Optional Equipment

For more detailed information about cab and powertrain equipment, please refer to separate specification sheets.

For all possible options and combinations of options please consult your Volvo sales contact who can create a specification to match your requirements using the Volvo Sales Support system (VSS).

The factory reserves the right to modify design and change equipment without previous notification. The specification can vary from country to country.

- RTH2610F** RTH2610F hub reduction tandem 26tonne drive axles, GCW 100 tonnes with differential and cross locks*
* Cross locks replaced by a dog clutch if tandem axle lift is specified
- RTS2310A** RTS2310A single reduction tandem 23tonne drive axles with differential and cross locks* - design GCW 100tonnes.
* Cross locks replaced by a dog clutch if tandem axle lift is specified.
- RTS2370A** RTS2370A single reduction tandem 23tonne drive axles with differential and cross locks* - design GCW 70tonnes.
* Cross locks replaced by a dog clutch if tandem axle lift is specified.

PACKAGES

- LHFP-VE** Long Haul Fuel Economy driving package
 - LHFP-VE+** Long Haul Fuel Economy plus driving package
 - DRIVE** Cab Package: Drive
 - DRIVE+** Cab Package: Drive +
 - DRIVE++** Cab Package: Drive ++
 - 1BED** Living package with single bed:
 - 1BED+** Living package with single bed plus:
 - 2BED** Living package with two beds:
 - 2BED+** Living package with two beds plus:
 - AUDHIG** High Power Audio system: RDS radio with CD player - also playing MP3/WMA files from CD -, with integrated bluetooth phone and USB/Line inputs. FM/AM antenna, speakers in dashboard, doors, and sleeping compartment.
 - MEDIA** AM/FM Bluetooth radio without CD player. USB and Aux line inputs. Speakers in dashboard, doors, and sleeping compartment. 7" touch screen with personal apps.
 - MEDIADF** AM/FM Bluetooth radio without CD player. USB and Aux line inputs. Speakers in dashboard, doors, and sleeping compartment. 7" touch screen with personal and professional apps. Dynafleet vehicle on-board data display with office internet support.
 - MEDIANAV** AM/FM Bluetooth radio without CD player. USB and Aux line inputs. Speakers in dashboard, doors, and sleeping compartment. 7" touch screen with personal and professional apps. Truck based satellite navigation (live updates not included)
 - MEDIANDF** AM/FM Bluetooth radio without CD player. USB and Aux line inputs. Speakers in dashboard, doors, and sleeping compartment. 7" touch screen with personal and professional apps. Truck based satellite navigation (live updates not included) Dynafleet vehicle on-board data display with office internet support.
 - VISI15** Visibility Package
 - VISI15+** Visibility Plus Package
 - VISIC15** Visibility Package
 - RCHAPAC1** Chassis Package Rigid
- ## CHASSIS
- FST-AIR** Front suspension type - air
 - FST-PAR** Front suspension type - 2 leaf parabolic springs
 - FST-PAR3** Front suspension type - 3 leaf parabolic springs
 - FSLs-BAS** Front suspension levelling - basic stroke
 - FSLs-HI** Front suspension levelling - high stroke for demount operations - check with bodybuilder
 - FAL10.0** Front axle design capacity 10 tonnes - Ensure that you have checked the tyre load index
 - FAL9.0** Front axle design capacity 9.0 tonnes - Ensure that you have checked the tyre load index
 - FSM-LUB** Lubricated rear shackles on front suspension pins and bushings
 - FSTAB** Front anti-roll bar
 - FSTAB2** Front anti-roll bar medium stiffness
 - FSTAB3** Front stiff anti-roll bar

MODEL RANGE

FH 13 8x4 Rigid - Tag Tridem – contact sales engineering reference application FH 84

- **RAL27** Rear bogie design capacity 27 tonnes
- **RAL33** Rear bogie design capacity 33 tonnes
- **RAL36** Rear bogie design capacity 36 tonnes
- **RSTAB3** Rear stiff anti-roll bar
- **RALIM105** Rear axle load limiter, 10.5 tonnes
- **RALIM115** Rear axle load limiter, 11.5 tonnes
- **RALIM13** Rear axle load limiter, 13 tonnes
- **RALIM95** Rear axle load limiter, 9.5 tonnes
- **ACTST-TO** Volvo Dynamic Steering (VDS) with with extra electronic pump and torque overlay
- **ASFE-BAS** Active steering feature - Basic - Volvo Dynamic Steering only
- **ASFE-PS** Active steering feature - Volvo Dynamic Steering with personal settings
- **PSS-DUAL** Dual power steering system
- **PSS-SING** Single power steering system
- **PSP-VAR** Power steering pump with variable displacement
- **EBS-MED** EBS medium package including "hill" hold function
- **AUXPARK** Additional spring parking brakes
- **FRAME300** Frame rail section external height 300 mm
- **FST7070** Frame thickness - web and flange 7.0mm
- **FST8080** Frame thickness - web and flange 8.0mm
- **FIL-EEEB** Inner liner from end of engine to end of bogie
- **FIL-EEEF** Inner liner from end of engine to end of frame
- **FIL-FBEB** Inner liner over rear bogie
- **FIL-FBEF** Inner liner from front of bogie to end of frame
- **FIL-TXEB** Inner liner from gearbox member to end of bogie
- **FIL-TXEF** Inner liner from gearbox member to end of frame
- **BBOX-L** Battery box located on left hand side
- **BATS-D** Dual energy battery system - 2 living batteries and 2 starter batteries.
- **BATS-S** Single energy battery system (2 batteries)
- **2BAT210B** 2 x 210 Ah capacity Gel batteries
- **2BATT170** 2 x 170 Ah capacity batteries
- **2BATT225** 2 x 225 Ah capacity batteries
- **BATTAMP** Battery voltage and ampere gauge
- **BATTIND** Battery charge indication
- **ADR2** ADR package for transportation of dangerous goods on road (Note does NOT include safe loading pass package if required this is quoted separately)
- **MSWI-A** Main switch - ADR switch circuit shut down
- **MSWI-C** Main switch - Chassis mounted toggle switch by battery box
- **MSWI-R** Main switch - Key fob operated remote controlled
- **R330A71** Right aluminium 710 mm D-shaped fuel tank, 330 litres volume
Min volume 255l
Max volume 810l
- **UL-FUEL** Without left fuel tank
Min volume 160l
Max volume 730l
- **ADTP-L** AdBlue tank on left hand side
- **ADTP-R** AdBlue tank on right hand side
- **ADB048** AdBlue tank usable volume 48 litres
- **ADB064** AdBlue tank usable volume 64 litres
- **ADB068** AdBlue tank usable volume 68 litres
- **ADB090** AdBlue tank usable volume 90 litres
- **ADB100** AdBlue tank usable volume 100 litres
- **ADTC-BF** AdBlue tank cover with satin alloy look decorative cover
- **FCAP-L** Locking fuel filler cap
- **FUFF-AS** Fuel filling anti-spillage device
- **FUFF-ATS** Fuel filling anti-theft and anti-spillage devices
- **ESH-LEFT** Horizontal silencer, left exhaust outlet
- **ESH-REAR** Horizontal silencer, rear exhaust outlet
- **ESH-RIGH** Horizontal silencer, right exhaust outlet
- **ESH-VERT** Horizontal silencer, vertical exhaust outlet
- **EXST-SSP** Stainless steel exhaust stack - NOT polished
- **EXST-ST** Steel exhaust stack
- **HS-NAR** Narrow heat shield
- **WHC-FIX2** Two fixed wheel chocks
- **WHC-FOL2** Two foldable wheel chocks
- **WHCP-F** Wheel chock(s) stored in the front part of the vehicle
- **WHCP-M** Wheel chock(s) stored in the middle part of the vehicle
- **WHCP-R** Wheel chock(s) stored in the rear part of the vehicle
- **WHCP-T** Transport mounted wheel chock(s) stored in cab outer luggage locker
- **TB-L80** Toolbox 800 mm, left side
- **TB-R80** Toolbox 800 mm, right side
- **SUP-BAS** EC approved chassis side guards
- **SUP-LOW** EC approved low chassis side guards
- **CHAIN-S** Snow chains
- **HOOK-SC** Snow chain hooks
- **TOWF-NO1** One front towing device
- **TOWF-NO2** Two front towing devices
- **TOWMBRH** Towing member, high mounted in centre of frame, D = 190
- **TOWMBRL1** Towing member, low mounted under the frame
- **TOWMBRM** Towing member, medium mounted in line with frame lower flange
- **RFEC-S** Rear frame end, straight cut for regular platform applications
- **RFEC-U** Rear frame end, upper cut for tipper applications.
- **C-RI4040** Towing coupling, Ringfeder 4040 G-150
- **C-RI5055** Towing coupling, Ringfeder 5055 G-150
- **C-RO400G** Towing coupling, Rockinger 400 G-150 for 40mm eyes
- **C-RO50** Rockinger RO 50 50mm for centre axle trailer
- **TOWR-ONE** Towing hitch attached to rear crossmember
- **TREL-PK** Trailer electrical preparation kit - chassis/cab wiring
- **TREL14** Single 14 pole electrical trailer connector
- **TREL15** Single 15 pole electrical trailer connector - ADR certified
- **TREL7** 7 pole - 24N trailer electrical suzie
- **TREL7-7** 24N and 24S trailer electrical suzies
- **TBC-DUO** Duomatic type air line connectors
- **TBC-EC** Palm coupling type air line connectors
- **TRBR-HCF** Full pressure hand controlled trailer brake
- **TRBR-STA** Stationary trailer brake control
- **TRB-STRE** Stretch Brake - Automatic low speed trailer brake activation to avoid jack-knifing and improve steerability
- **RUP-FOSL** Folding & sliding EC approved aluminium rear underrun
- **RFEND-B** Three piece EC approved rear mud wings and spray flaps
- **RFEND-T** Rear mud wings, transport mounted
- **RFH-BAS** Basic rear wing height
- **RFH-HIG** High rear wing height - higher wing tops
- **RFH-LOW** Lower rear wing height - shallower wing tops
- **AUXATNK** Auxiliary airtank
- **ATANK-AL** Aluminium air tanks
- **ATANK-ST** Steel air tanks
- **TL-LED** Rear lights LED
- **BLIGHT-E** Emergency brake light

WHEELS & TYRES

- **RT-AL** Alcoa brushed aluminium rims with standard holes for long stud fixing on all axles
- **RT-ALDP** Alcoa Dura-Bright EVO aluminium rims with standard holes long stud fixing on all axles, requires cleaning with a ph neutral solution - washing up liquid.

■ Standard Equipment □ Optional Equipment

For more detailed information about cab and powertrain equipment, please refer to separate specification sheets.

For all possible options and combinations of options please consult your Volvo sales contact who can create a specification to match your requirements using the Volvo Sales Support system (VSS).

The factory reserves the right to modify design and change equipment without previous notification. The specification can vary from country to country.

MODEL RANGE

FH 13 8x4 Rigid - Tag Tridem – contact sales engineering reference application FH 84

- **RT-ALDPD** Alcoa Dura-Bright EVO aluminium rims with countersunk holes for short stud fixing on all axles, requires cleaning with a ph neutral solution - washing up liquid.
 - **RT-ALDU** Alcoa brushed aluminium rims with countersunk holes for short stud fixing on all axles
 - **RT-STEEL** Steel rims on all axles
 - **WCAP** Aerodynamic hub caps
 - **SPWT-D** Spare wheel & tyre with rear tyre pattern
 - **SPWT-F** Spare wheel & tyre with front tyre pattern
 - **SWCP-LF** Spare wheel carrier on left side of chassis ahead of rear axle
 - **SWCP-R** Rear mounted spare wheel carrier
 - **SWCP-T** Spare wheel supplied temporarily strapped to chassis
 - **SWCP-TP** Temporary spare wheel carrier on top of chassis frame
 - **JACK-12T** 12 tonne bottle jack
 - **JACK-15T** 15 tonne bottle jack
 - **JACK-20T** 20 tonne bottle jack
 - **TOOL-BAS** Basic Toolkit
 - **TOOLKIT** Complete tool kit
 - **INFLAHOS** Tyre inflation hose
 - **GAUGE-TP** Tyre pressure gauge
- DRIVELINE EQUIPMENT**
- **ASO-C** Crawler gear -
Ratio direct top gearbox 19:1
Ratio Overdrive gearbox 17:1
 - **ASO-ULC** Ultra low crawler and crawler gear -
Ratios direct top gearbox 32:1 and 19:1
Ratios Overdrive box 32:1 and 17:1
 - **TRAP-HD** Reinforced gearbox application
 - **TP-CON** Construction Package
 - **TP-DIST** Distribution Package
 - **TP-HD** I-shift software - Heavy duty for high GCW
Special conditions apply consult Sales Engineering
 - **TP-LONG** Long Haul Package
 - **AMSO-AUT** Enhanced I-shift software with manual shift available in auto mode and kickdown facility on accelerator pedal
 - **AVO-ENH** Enhanced software for off road driveability and starting
 - **APF-ENH** I-shift enhanced PTO functions
 - **RET-TH** Gearbox mounted retarder
 - **TC-MAOH2** Extra high performance transmission oil cooler - air to oil with front mounted radiator
 - **TC-MWO** Basic transmission oil cooler - water to oil
 - **2COM1100** Two cylinder, air compressor, 1100 litres per minute
 - **2COMP900** Two cylinder, air compressor, 900 litres per minute
 - **CLU-AIRC** Clutchable air compressor
 - **AIRIN-FR** Front air intake fitted to the underside of cab engine tunnel
 - **AIRIN-HI** Roof mounted air intake behind cab on left hand side
 - **AIRIN-LO** Low level air intake behind cab on left hand side
 - **ACL1ST-S** Two stage air filter
 - **24AL110B** 110 amp alternator
 - **24AL120B** 120 amp alternator
 - **24AL150B** 150 amp alternator
 - **CCV-C** Closed crankcase engine ventilation
 - **CCV-OX** Closed crankcase ventilation for cold markets
 - **PRIM-EL** Electrical priming pump
 - **PRIM-MAN** Manual priming pump
 - **AF-R** Hot fuel recirculation heated fuel filter
 - **FUEFE2LW** Large engine mounted dual fuel filter with water separator
 - **FUEFE2SW** Small engine mounted dual fuel filter with water separator
 - **EST-AID** Air inlet manifold starting heater element
 - **220EBH15** 220V/1.5Kw electric engine block heater
 - **PTER-100** Rear engine mounted power-take-off with DIN 100 / ISO 7646 flange
 - **PTER-DIN** Rear engine mounted PTO with DIN5462 (female) splined shaft for a close coupled pump.
Models with 3 steering axles will use this to drive the steering pump (AUXPSP)
 - **PTER1400** Rear engine mounted power-take-off with SAE 1410 flange
 - **HPE-F101** Parker F1-101, engine mounted, fixed displacement, single flow, engine mounted hydraulic pump
 - **HPE-F41** Parker F1-41, engine mounted, fixed displacement, single flow, engine mounted hydraulic pump
 - **HPE-F51** Parker F1-51, engine mounted, fixed displacement, single flow, engine mounted hydraulic pump
 - **HPE-F61** Parker F1-61, engine mounted, fixed displacement, single flow, engine mounted hydraulic pump
 - **HPE-F81** Parker F1-81, engine mounted, fixed displacement, single flow, engine mounted hydraulic pump
 - **HPE-T53** Parker F2-53/53, engine mounted, Fixed displacement, Twin flow engine mounted hydraulic pump
 - **HPE-T70** Parker F2-70/35, engine mounted, Fixed displacement, Twin flow engine mounted hydraulic pump
 - **HPE-V45** Parker VP1-45, variable displacement, single flow, engine mounted hydraulic pump
 - **HPE-V75** Parker VP1-75, variable displacement, single flow, engine mounted hydraulic pump
 - **PTR-D** Gearbox PTO for plug-in pump, 0.71xeng speed
 - **PTR-DH** Gearbox driven high speed PTO for one plug-in hydraulic pump
 - **PTR-DM** Gearbox driven medium speed PTO for one plug-in hydraulic pump
 - **PTR-F** Gearbox driven PTO with rear flange connection
 - **PTR-FH** Gearbox driven high speed PTO with SAE drive flange
 - **PTR-FL** Gearbox driven low speed PTO with SAE drive flange
 - **PTRD-D** Gearbox driven HIGH SPEED PTO for two plug-in hydraulic pumps
 - **PTRD-D1** PTRD-D1 Gearbox driven HIGH SPEED PTO (1 SAE flange & 1 plug-in hydraulic pump)
 - **PTRD-D2** Gearbox driven HIGH SPEED PTO (2 SAE flanges & 1 plug-in hyd pump)
 - **PTRD-F** PTO with 1 DIN + 1 flange connection rear, manual gearbox
 - **HPG-F101** Parker F1-101 gearbox mounted, fixed displacement, single flow, hydraulic pump
 - **HPG-F41** Parker F1-41 gearbox mounted, fixed displacement, single flow, hydraulic pump
 - **HPG-F51** Parker F1-51 gearbox mounted, fixed displacement, single flow, hydraulic pump
 - **HPG-F61** Parker F1-61 gearbox mounted, fixed displacement, single flow, hydraulic pump
 - **HPG-F81** Parker F1-81 gearbox mounted, fixed displacement, single flow, hydraulic pump
 - **EIDLESD** Engine idle shut down
 - **DTRI-PER** Dashboard in darker peregrine greyish brown. Steering wheel grey and door panels in light beige for FH and black for FH16.
 - **DTRI-SRA** Dashboard and steering wheel cover in light beige skylark. Door panels in light beige for FH and black for FH16.
 - **STWPOS-R** RIGHT HAND DRIVE
 - **STWM-LE** Leather steering wheel
 - **STGW-AD2** Adjustable steering wheel with neck tilt
 - **STGW-ADJ** Adjustable steering wheel
 - **AIRBAG** SRS Driver's air bag
 - **DRC-AMII** DPF Regeneration control switch - for manual and switching off regeneration
 - **1DAYDIG2** Continental VDO DTCO 4.0 smart tachograph
This tachograph can ONLY offer remote download if the option of Dynafleet or an FMS gateway has been specified with this order.
 - **1DAYDIGP** Continental VDO DTCO 3.0 digital tachograph
For vehicles with long lead time - this includes prep kit for the

■ Standard Equipment □ Optional Equipment

For more detailed information about cab and powertrain equipment, please refer to separate specification sheets.

For all possible options and combinations of options please consult your Volvo sales contact who can create a specification to match your requirements using the Volvo Sales Support system (VSS).

The factory reserves the right to modify design and change equipment without previous notification. The specification can vary from country to country.

MODEL RANGE

FH 13 8x4 Rigid - Tag Tridem – contact sales engineering reference application FH 84

	retrofit of DTCO 4.0 tachograph. For updating to new legal demand for trick registration from 15th June 2019. This tachograph can ONLY offer remote download if the option of Dynafleet or an FMS gateway has been specified with this order.	<input type="checkbox"/> AIDKIT	First aid kit
<input type="checkbox"/> ARSL	Additional road speed limit - switch in dashboard	<input type="checkbox"/> AIDKIT1B	First aid kit
<input type="checkbox"/> CRUIS-E	Eco cruise control (with eco-roll and I-cruise, controls in steering wheel)	<input type="checkbox"/> WARNLAMP	Portable warning lamp
<input checked="" type="checkbox"/> CRUISEC	Cruise control, standard	<input type="checkbox"/> LAMP-IN	Inspection lamp
<input type="checkbox"/> ESP-BAS1	Electronic Stability Control	<input type="checkbox"/> BULBKIT	Bulb and fuse kit
<input type="checkbox"/> ESPC-RO	ESP (Electronic Stability Program) functionality control - Reduced / Off	<input checked="" type="checkbox"/> WRITEPAD	Writing pad
<input type="checkbox"/> HWSS-ACB	Adaptive cruise control ACC with forward collision warning and AEBS advanced emergency brake system	<input type="checkbox"/> UPHTRI01	Interior trim: Seats: Black embossed textile insert, black vinyl bolster with red vinyl side insert Cab walls: In matching grey vinyl
<input type="checkbox"/> HWSS-FCB	Forward collision warning with AEBS advanced emergency brake system	<input type="checkbox"/> UPHTRI02	Interior trim: Seats: Black striped textile insert, black smooth textile bolster & red vinyl side insert Cab walls: Textile with matching grey nuances
<input type="checkbox"/> LSS-DW	Lane departure-warning system	<input type="checkbox"/> UPHTRI03	Interior trim: Seats: Grey/beige soft striped textile insert, grey/beige smooth textile bolster Cab walls: soft textile in matching grey and beige colours
<input type="checkbox"/> LCS	Lane change support	<input type="checkbox"/> UPHTRI05	Interior trim: Seats: Light grey leather insert and black leather bolster Cab walls: In matching grey vinyl
<input type="checkbox"/> DAS-W	Driver Alert Support system	<input type="checkbox"/> UPHTRI06	Interior trim: Seats: Light grey leather insert and black leather bolster Cab walls: soft textiles in matching grey nuances
<input type="checkbox"/> RSENS-W	Rain sensing windscreen wipers	<input type="checkbox"/> UPHTRI07	Interior trim: Seat: Light grey leather insert black edging Cab walls: soft textiles in matching grey, and beige
<input type="checkbox"/> CU-ECC	Electrically controlled air conditioning with sun sensor	<input checked="" type="checkbox"/> DST-CF4	Driver seat, comfort, suspended, belt in seat
<input type="checkbox"/> CU-ECC2	Electrically controlled air conditioning with sun sensor, mist sensor, air quality sensor and carbon filter	<input type="checkbox"/> DST-CF5	Driver seat, comfort, suspended, belt in seat, electrically heated
<input checked="" type="checkbox"/> CU-MCC	Climate unit with manual controlled air conditioning	<input type="checkbox"/> DST-CF6	Driver seat, comfort, suspended, belt in seat, electrically heated, ventilated
<input checked="" type="checkbox"/> IMMOBIL	Thatcham H2 approved immobiliser	<input type="checkbox"/> DST-LUX1	Deluxe suspended drivers seat features: electrical adjustment with memory function, seatbelt in seat with heated & ventilated cushions
<input type="checkbox"/> ALARM-B	Thatcham H1 approved vehicle alarm - Cab only	<input type="checkbox"/> DST-LUX2	Deluxe suspended drivers seat features: electrical adjustment with memory function, seatbelt in seat and heated cushions
<input type="checkbox"/> ALARM-E	Enhanced vehicle alarm - Thatcham H1 approved - Cab plus external sensor for body/trailer	<input type="checkbox"/> SBD-RED	Red seat belts
<input type="checkbox"/> ALCOLOCK	Alcolock	<input type="checkbox"/> SBPRE-DS	Driver seat belt pretensioner
<input type="checkbox"/> AMPL400	Radio amplifier, 8 channel, 400 W with subwoofer Located in right hand external storage box	<input type="checkbox"/> PST-BAS1	Passenger seat - Fixed non suspended fold up with seatbelt mounted in cab
<input type="checkbox"/> BUPMON	Back up monitor with built in 7" screen on dash and one colour camera supplied loose for fitment by bodybuilder. Can accommodate up to 4 cameras for TFL Safe Scheme, CLOCS and FORS.	<input type="checkbox"/> PST-BSL1	Passenger seat - Sliding non suspended fold up with seatbelt mounted in cab
<input type="checkbox"/> PHONE-PK	Telephone preparation kit (antenna, antenna attachm. cable incl.)	<input type="checkbox"/> PST-CF4	Passenger seat - Comfort suspended with seatbelt mounted in seat
<input checked="" type="checkbox"/> WLIFT-AD	Electrical window lift, automatic up/down driver side	<input type="checkbox"/> PST-CF5	Passenger seat - Comfort suspended & heated with seatbelt mounted in seat
<input type="checkbox"/> ISUNS-BS	Side interior sun visor on both sides	<input type="checkbox"/> PST-RX1	Passenger seat - Fixed non suspended, features: 90 degree rotation and tilt function with seatbelt mounted in cab
<input checked="" type="checkbox"/> ISUNS-DS	Driver's side interior sun visor	<input type="checkbox"/> PST-RX2	Passenger seat - Fixed non suspended, features: 90 degree rotation, tilt and heated functions with seatbelt mounted in cab
<input type="checkbox"/> ISUNF-RE	Electrically operated textile interior sun blind	<input type="checkbox"/> PST-STD2	Passenger seat - Fixed non suspended with seatbelt mounted in cab
<input checked="" type="checkbox"/> ISUNF-RM	Manually operated textile interior sun blind	<input checked="" type="checkbox"/> PST-STD4	Passenger seat - Standard suspended with seatbelt mounted in cab
<input checked="" type="checkbox"/> CSPL-BX	Lower center dash open storage box	<input type="checkbox"/> SBPRE-PS	Passenger seat belt pretensioner
<input type="checkbox"/> CSPL-BXD	Lower centre dash drawer	<input type="checkbox"/> ARMRE-BB	Two armrests on both driver and passenger seat.
<input type="checkbox"/> CSPU-SDR	One open storage and one drawer - behind push open lid - in upper part of the centre dash panel	<input type="checkbox"/> ARMRE-DB	Two armrests, on driver seat only
<input checked="" type="checkbox"/> CSPU-SS	Two open storages - behind push open lid in upper part of the centre dash panel	<input type="checkbox"/> ARMRE-PB	Two armrests, on passenger seat only
<input type="checkbox"/> ADFS	Two extra DIN slots in front shelf - can be fitted with card or drawer available as an accessory	<input type="checkbox"/> ARU-BAS	Vinyl upholstered armrest
<input checked="" type="checkbox"/> BUPALARM	Reverse alarm	<input type="checkbox"/> ARU-LEA	Leather upholstered armrest
<input type="checkbox"/> RTOLL-PK	Road toll PREPARATION kit for trucks operating with "Toll Collect" in Germany	<input checked="" type="checkbox"/> GRABHI-B	Steel instep cab grab handle
<input type="checkbox"/> LOADIND	Load indicator with central dashboard display	<input type="checkbox"/> GRABHI-L	Leather covered instep cab grab handle
<input type="checkbox"/> REMC-MF	Multi-functio wireless remote control	<input checked="" type="checkbox"/> FMAT-RUB	Rubber floor mats
<input type="checkbox"/> FIREXT3S	3kg fire extinguisher mounted on seat base	<input type="checkbox"/> FMAT-TX2	Textile and rubber floor mats
<input type="checkbox"/> WARNVEST	High visibility warning vest - no sleeves	<input checked="" type="checkbox"/> LBK80F	Lower fixed bunk with wide middle section 815 in the centre x
<input checked="" type="checkbox"/> Standard Equipment			
<input type="checkbox"/> Optional Equipment			

For more detailed information about cab and powertrain equipment, please refer to separate specification sheets.

For all possible options and combinations of options please consult your Volvo sales contact who can create a specification to match your requirements using the Volvo Sales Support system (VSS).

The factory reserves the right to modify design and change equipment without previous notification.
The specification can vary from country to country.

MODEL RANGE

FH 13 8x4 Rigid - Tag Tridem – contact sales engineering reference application FH 84

- LBK80FRE** 2000 mm
Lower electrically operated recline bunk with wide middle section 815 in the centre x 2000 mm
 - LBK80FRM** Lower manually operated recline bunk with wide middle section 815 in the centre x 2000 mm
 - MATL-FI** Firm lower bunk pocket sprung mattress
 - MATL-SF** Lower flexizone mattress - semi-firm, pocket springs up to 100kg - 16 stone
 - MATL-SO** Lower flexizone mattress - soft, pocket springs up to 85kg - 13.5 stone
 - OLMAT-BA** 35mm mattress overlay protector
 - OLMAT-PR** 50mm premium mattress overlay protector
 - TBK60AD** Height adjustable foldable top bunk 600 x 1900mm
 - TBK60F** Fixed foldable top bunk 600 x 1900mm
 - TBK70AD** Height adjustable foldable top bunk 700 x 1900mm
 - TBK70F** Fixed foldable top bunk 700 x 1900mm
 - PH-CAB2** 1.8kW Air to air night heater
 - PH-ENGCA** Engine and cab night heater
 - SLCP-BAS** Basic sleeper control panel - includes interior light, parking heater, roof hatch and door lock
 - SLCP-LUX** Luxury sleeper control panel - includes interior light, parking heater, roof hatch, door lock, alarm clock, window and radio
 - SAFE** Safe box for driver's personal items
 - RUS-BAS** Rear cab upper storage 154 litres - 300 mm high
 - RUS-HIG** Rear cab upper storage 245 litres - 440 mm high
 - TABLE** Folding and height adjustable table - on lower bunk
 - REFR-RUS** Fridge: 28 litre rear upper wall mounted with dividers
 - REFRIG** Fridge: 33 litre under bunk mounted with freezer dividers
 - MICRO-PK** Preparation kit for microwave oven (wiring)
 - BOTH-D** One bottle holder under dashboard centre section
 - BOTH-DL** Two bottle holders, one under dashboard centre section and one mounted to the under bunk drawer
 - BOTH-L** One bottle holder mounted to the under bunk drawer
 - COFMA-PK** Coffee maker, preparation kit.
 - INLI-BAS** Interior white LED lights - basic
 - INLI-NL** Interior white and red night LED light with no dimmer
 - INLI-NLD** Interior white and red night LED light with dimmer
 - ARL-FLEX** Two flexible reading lamps (snake lamps)
 - RH-EE** Without roof hatch -Tinted glass emergency exit ONLY
 - RH-ETR** Glass roof & escape hatch - Electrically operated, tinted glass with rear opening
 - RH-MTR** Glass roof & escape hatch - Manually operated, tinted glass with rear opening
 - URH** Without roof hatch
 - SWIND-BS** Extra side window on both sides behind "B" pillar
 - VANMIR** Vanity mirror in front shelf
 - AS-FUS** Extra shelf in front upper storage compartments
 - INFOT-PK** Preparation kit for the mounting of a flat screen TV in cab above the driver's door, includes bracket, electrical and speaker connections
- CAB EXTERIOR**
- EXTL-BAS** Basic exterior finish - - Matt Volvo badges, grey instep, bumper, bumper spoiler, mirror housing and sun visor
 - EXTL-ENH** Enhanced exterior finish - Chrome style Volvo badges, painted instep, bumper, bumper spoiler if specified, mirror housing and sun visor
 - GLAS-TIN** Tinted windows.
 - DGLAS-H** Tempered door glass
 - DGLAS-L** Laminated door glass
 - LOCK-REM** Central locking with remote control
 - BUMP-B** Plastic front bumper
 - BUMP-B2** Steel front bumper
 - BUMP-HD** Heavy duty front bumper
 - BUMP-SP** Front bumper spoiler
 - GUARD-EH** Engine guard to protect sump and engine hoses
 - BUGNET** Insect screen in front of radiator
 - CTILTP-E** Electrically operated hydraulic cab tilt
 - CTILTP-M** Manually operated hydraulic cab tilt
 - FCABS-A** Front cab suspension - Air
 - FCABS-M** Front cab suspension - Mechanical spring
 - RCABS-A** Rear cab suspension - Air
 - RCABS-M** Rear cab suspension - Mechanical spring
 - HCC-INEX** Exterior and interior hood catch control
 - MIRCOMF** Electrically heated and operated main and wide angle mirrors and manually adjusted kerb view mirror on passenger side
 - MIRSTD** Electrically heated main and wide angle mirrors and manually adjusted kerb view mirror on passenger side
 - AMIR-F20** Auxiliary front view mirror with a 200mm radius
 - SUNV-H** External smoke grey sunvisor
 - AD-ROOF** Roof air deflector
 - AD-SIDES** Short cab side air deflector for rigid bodywork
 - HL-BASIC** Halogen H7 head lamps
 - HL-BHID** High intensity Bi-Xenon head lamps
 - HL-DBL** Bi-Xenon high intensity discharge and dynamic head lamps. Dipped beam follows the road, activated by a signal from the steering system.
 - HL-CLEAN** Head lamp cleaner - washer jets
 - HLP-ST** Headlamp protection
 - HL-ADJ** Headlight adjustment - Switch in cab
 - DRIVL2** Two spot lamps
 - UDRIVL** Without auxiliary driving lights
 - FOGL-WC** Front fog lights
 - CL-STAT** Static corner lights
 - ASL-RF2** Two Hella H11 70W spotlamps in sign box - only available with the basic headlight and no lower driving lights.
 - BEACO2F** Two front roof mounted amber beacon rotating warning lamps
 - BEACO2R** Two rear roof mounted (on accessory bracket) amber beacon flashing warning LED lamps
 - BEACON-P** Roof beacon wire preparation
 - BEACONA4** Four roof mounted (2 front/2 rear) amber beacon rotating warning lamps
 - CABPT-R1** Single outlet for roof mounted accessories
 - CABPT-R2** Twin outlets for roof mounted accessories.
 - SPOTP-F** Spotlamp preparation in front, max 280W
 - SPOTP-R** Spotlamp preparation on roof, max 280W
 - SPOTP-RF** Spotlamp preparation on cab roof and in cab front, max 2x280W
 - ROS-IL2** Preparation kit for illuminated roof sign with switch loose in cab, fit after registration
 - CSGN-GTR** "Globetrotter" headboard logo
 - HORN-F1S** Single tone Jericho air horn chassis mounted
 - HORN-R2S** Two roof mounted air horns
 - ANT-CBR** Roof mounted antenna for CB radio, single aerial
 - ACCBP-AP** Front, middle & rear roof mounted accessory brackets
 - ACCBP-F** Front roof mounted accessory bracket
 - ACCBP-FM** Front & middle roof mounted accessory brackets
 - ACCBP-FR** Front & rear roof mounted accessory brackets
 - ACCBP-M** Middle roof mounted accessory bracket
 - ACCBP-R** Rear roof mounted accessory bracket
 - ACCBP-RM** Rear & middle roof mounted accessory brackets

Standard Equipment

Optional Equipment

For more detailed information about cab and powertrain equipment, please refer to separate specification sheets.

For all possible options and combinations of options please consult your Volvo sales contact who can create a specification to match your requirements using the Volvo Sales Support system (VSS).

The factory reserves the right to modify design and change equipment without previous notification. The specification can vary from country to country.

MODEL RANGE

FH 13 8x4 Rigid - Tag Tridem – contact sales engineering reference application FH 84

- STUC-B** Left and right storage compartments under cab
- STUC-L** Left storage compartment under cab
- STUC-R** Right storage compartment under cab
- REFS-TW** White cab conspicuity markings by packed in cab
- REFS-TY** Yellow cab conspicuity markings by packed in cab

SUPERSTRUCTURE PREPARATIONS

- SRWL-PK** Wiring preparation for side & rear work/reverse lamps on side of chassis and a three-position switch, maximum 280W
- SWL-2FW** Two H3 70W white front chassis mounted (LH/RH side) working lamps and a 2-position switch (On/Off)
- SWL-2RW** Two H3 70W white rear chassis mounted (LH/RH side) working lamps and a 2-position switch (On/Off)
- SWL-4W** 4 H3 70W white front (2) & rear (2) chassis mtd (LH/RH side) working lamps & 2-pos switch (On/Off)
- SWL-PK** Wiring preparation for side work/reverse lamps on side of chassis and a three-position switch, maximum 280W
- WLC-H2W** Two H3/70W white working lamps high mounted on the back of cab
- WLC-PKCH** Preparation kit (cables and switch) for cab mounted chassis working lamp
- WLC-PKH** Preparation kit, cables and switch for high mounted working lamps back of cab
- WLC-PKL** Preparation kit, cables and switch for low mounted working lamps back of cab
- WLC-PKLH** Preparation kit - cables and switch for low and high mounted working lamps back of cab.
- **ECBB-BAS** Body builder electrical centre without body builder module
- ECBB-HIG** Body builder electrical centre with body builder module
- BBCHAS1** One 7-pole connector for Body builder interface
- BBCHAS3** Three 7-pole connectors for Body builder interface
- BEPR-T2** Body builder electrical software preparation for tipper with remote control
- EXSTER** External steering control, with VDS and bodybuilder module
- **TD-LED** Trailer detection with LED sensing
- FRFS-BS** Frame rail free space on both sides to give space for crane legs or other equipment.
- FBA-BTF** Lower front body attachments for torsionally flexible - platform body
- FBA-BTSF** Lower front body attachments for torsionally semi-flexible body - box or curtainsider
- HBA-FSFB** Holes for body attachments - flexible/semi-flexible body
- HBA-SB** Holes for body attachments - stiff body
- RBA-T2** Lower rear body attachments for helper frame
- CRANEPK1** Crane plates mounted to frame, for cranes up to 10 tonne metre capacity
- CRANEPK2** Crane plates mounted to frame, for cranes up to 20 tonne metre capacity
- CRANEPK4** Crane plates mounted to frame, for cranes up to 40 tonne metre capacity
- AUXL-SPK** Electrical preparation kit - wiring and switch for snow plough lights
- TAILPRE2** Tail lift preparation kit, wireless remote operation
- TAILPREP** Taillift preparation kit - cab switch and warning in driver display
- AESW2** Two Body builder bistable electrical switches (marked AUX1 / AUX2)
- AESW2PK** 2 Body builder bistable el.switches (marked AUX1/AUX2) and prep. for 4 more switches
- AUXSW-4** Wiring for 4 extra switches (from Body builder electrical centre to switch positions)

DELIVERY SERVICES

- **TGW-4GWL** GSM/GPRS/4G modem, LTE & WLAN for telematics gateway
- FMS-PK** Fleet Management System gateway

VOLVO

Volvo Truck Corporation
volvotrucks.com