

# MODEL RANGE

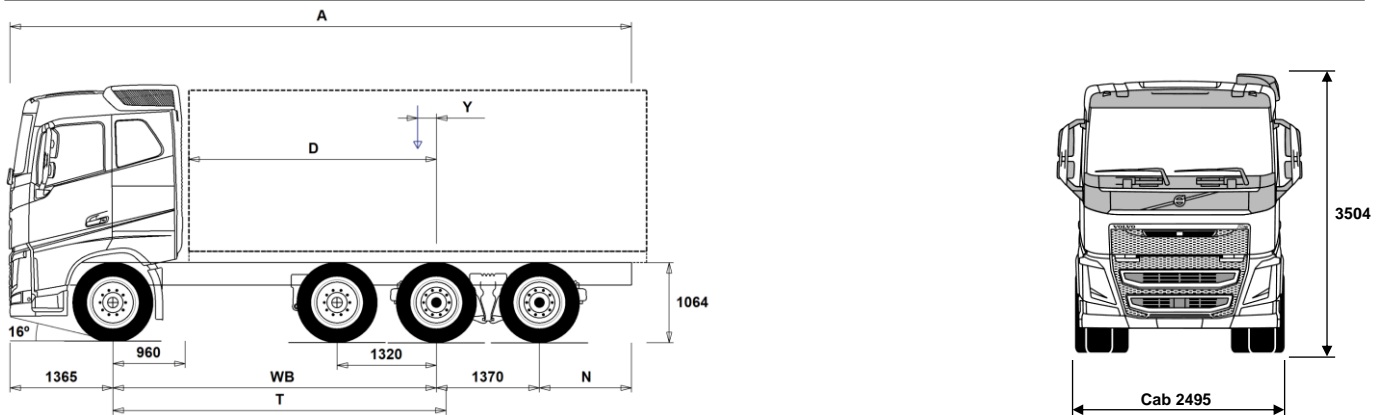

Volvo Trucks. Driving Progress

FH 16 8x4 Rigid - Pusher Axle Tridem – contact sales engineering reference application



## Chassis Dimensions [mm]

WB Wheelbase	4300	4600	4900	5100	5300	5600
A Overall Chassis Length	9410	9860	10310	10610	10810	11110
D Center of rear axle to front of body	3290	3590	3890	4090	4290	4590
N Rear Overhang (Min.)	1225	1225	1225	1225	1225	1225
N Rear Overhang (Max.)	2375	2525	2675	2775	2775	2775
T Theoretical Wheelbase	4428	4728	5028	5228	5428	5728
Y Center of Gravity for Payload (Min.)	-399	-424	-445	-460	-477	-506
Y Center of Gravity for Payload (Max.)	469	507	546	572	596	629

## Chassis Weights [kg]

Front Axle	5490	5515	5520	5525	5540	5570
Rear Bogie	4240	4290	4320	4345	4350	4370
Kerb Weight	9730	9805	9840	9870	9890	9940
Payload (including body, driver, fuel, etc.)	18620	18545	18510	18480	18460	18410

## Turning Diameter [mm]

Turning Circle Diameter Kerb to Kerb	18100	19000	20000	20600	21300	22200
Turning Circle Diameter Wall to Wall	19400	20300	21300	22000	22600	23600

## Plated Weights [kg]

	Plated	Design
Gross Vehicle Weight	28350	36000
Gross Combination Weight	44000	44000
Front Axle	8000	9000
Rear Bogie	24000	27000

## Important Notes

### Chassis Dimensions

Cab Height: +305 mm for CAB-HSLP, -283 mm for CAB-LSLP, +450 mm for CAB-XHSL.

D-measure includes a front clearance of 50 mm and for rigid trucks also a subframe of 100 mm.

Height can vary  $\pm 20$  mm for leaf and  $\pm 10$  mm for air suspension.

All dimensions are for unladen chassis and any tag axles down. Chassis height used: CHH-HIGH.

Rear overhang used for vehicle weight calculation is the maximum rear overhang (N Max.) for selected wheelbase.

Height change when chassis height CHH-MED,FRAME300: 0 mm.

Weight and dimensions are based upon the following tyres:

Front Axle Tyres:	315/80R22.5
Drive Axle Tyres:	315/80R22.5
Trailing/Pusher Axle Tyres:	315/80R22.5

**Chassis weight includes oil, water, AdBlue, 0 litres fuel and without driver. Kerb weight can vary  $\pm 3\%$ .**

Turning diameters are theoretically calculated. Tag axle used: PA-HYDRS.

Legal weights can differ from country to country.

For more detailed weight information, including optional equipment weights, ask your Volvo sales contact to enter your specification into the Volvo Weight Information system (WIS).

Do NOT use this drawing for bodybuilding. Refer to Volvo Bodybuilder Instructions and chassis assembly drawing FH84PR6HA.

# MODEL RANGE

## FH 16 8x4 Rigid - Pusher Axle Tridem – contact sales engineering reference application

### TRUCK USE

- RC-ROUGH** Operating class on/off road
- RC-SMOOT** Operating class highway
- TIPP-PRE** Tipper vehicle preparation
- UNIFORM** Basic platform vehicle

### CORE COMPONENTS

- CHH-HIGH** Chassis height high - N3 "On Road" chassis - For a specific loading height always check the unique BEP chassis drawing
- CHH-MED** Chassis height medium - For a specific loading height always check the unique BEP chassis drawing
- PU-EHYS** Electro-hydraulically steered pusher axle
- FH16HSLP** Globetrotter cab - all steel safety cage design with roof mounted emergency escape hatch. Designed and built to Swedish impact and ECE R29 regulations
- FH16SLP** Sleeper cab - all steel safety cage design with roof mounted emergency escape hatch. Designed and built to Swedish impact and ECE R29 regulations
- FH16XHSL** Globetrotter XL cab - all steel safety cage design with roof mounted emergency escape hatch. Designed and built to Swedish impact and ECE R29 regulations
- D16K550** D16K550 16litre engine developing 550hp at 1550-1900rpm SCR & EGR. Peak torque 2900Nm at 900-1350rpm. 2800Nm at 900-1400rpm with manual gearbox
- D16K650** D16K650 16litre engine developing 650hp at 1450-1900rpm SCR & EGR. Peak torque 3150Nm at 950-1450rpm.
- D16K750** D16K750 16litre engine developing 750hp at 1600-1800rpm SCR & EGR. Peak torque 3550Nm at 950-1400rpm.
- EBR-EPG** Exhaust brake controlled by steering column switch
- EBR-VEB+** Volvo engine brake + and exhaust pressure governor, enhanced performance from additional exhaust rocker control. Retardation 375kW
- AT2812F** AT2812E 12-speed "I-shift" automated mechanical gearbox suitable for gross train weights up to 60 tonne refer to sales engineering when used in conjunction with a PTO
- ATO3112F** ATO3112F 12-speed "I-shift" overdrive automated mechanical gearbox suitable for gross train weights up to 60tonne refer to sales engineering when used in conjunction with a PTO
- ATO3512F** ATO3512F 12-speed "I-shift" automated mechanical gearbox suitable for gross train weights up to 60 tonne refer to sales engineering when used in conjunction with a PTO
- RTH2610F** RTH2610F hub reduction tandem 26tonne drive axles, GCW 100 tonnes with differential and cross locks\*  
\* Cross locks replaced by a dog clutch if tandem axle lift is specified
- RTS2310A** RTS2310A single reduction tandem 23tonne drive axles with differential and cross locks\* - design GCW 100tonnes.  
\* Cross locks replaced by a dog clutch if tandem axle lift is specified.
- RTS2370A** RTS2370A single reduction tandem 23tonne drive axles with differential and cross locks\* - design GCW 70tonnes.  
\* Cross locks replaced by a dog clutch if tandem axle lift is specified.

### PACKAGES

- LHFP-VE** Long Haul Fuel Economy driving package
- LHFP-VE+** Long Haul Fuel Economy plus driving package
- DRIV16++** Cab Package: Drive ++
- DRIVE16+** Cab Package: Drive +
- 1BED** Living package with single bed:

- Standard Equipment
- Optional Equipment

For more detailed information about cab and powertrain equipment, please refer to separate specification sheets.

For all possible options and combinations of options please consult your Volvo sales contact who can create a specification to match your requirements using the Volvo Sales Support system (VSS).

The factory reserves the right to modify design and change equipment without previous notification. The specification can vary from country to country.

- 1BED+** Living package with single bed plus:
  - 2BED** Living package with two beds:
  - 2BED+** Living package with two beds plus:
  - AUDHIG** High Power Audio system: RDS radio with CD player - also playing MP3/WMA files from CD -, with integrated bluetooth phone and USB/Line inputs. FM/AM antenna, speakers in dashboard, doors, and sleeping compartment.
  - MEDIA** AM/FM Bluetooth radio without CD player. USB and Aux line inputs. Speakers in dashboard, doors, and sleeping compartment. 7" touch screen with personal apps.
  - MEDIADF** AM/FM Bluetooth radio without CD player. USB and Aux line inputs. Speakers in dashboard, doors, and sleeping compartment. 7" touch screen with personal and professional apps. Dynafleet vehicle on-board data display with office internet support.
  - MEDIANAV** AM/FM Bluetooth radio without CD player. USB and Aux line inputs. Speakers in dashboard, doors, and sleeping compartment. 7" touch screen with personal and professional apps. Truck based satellite navigation (live updates not included)
  - MEDIANDF** AM/FM Bluetooth radio without CD player. USB and Aux line inputs. Speakers in dashboard, doors, and sleeping compartment. 7" touch screen with personal and professional apps. Truck based satellite navigation (live updates not included) Dynafleet vehicle on-board data display with office internet support.
  - VISI15** Visibility Package
  - VISI15+** Visibility Plus Package
  - VISIC15** Visibility Package
  - RCHAPAC1** Chassis Package Rigid
- ### CHASSIS
- FST-AIR** Front suspension type - air
  - FST-PAR** Front suspension type - 2 leaf parabolic springs
  - FST-PAR3** Front suspension type - 3 leaf parabolic springs
  - FSL-BAS** Front suspension levelling - basic stroke
  - FSL-HI** Front suspension levelling - high stroke for demount operations - check with bodybuilder
  - FAL10.0** Front axle design capacity 10 tonnes - Ensure that you have checked the tyre load index
  - FAL9.0** Front axle design capacity 9.0 tonnes - Ensure that you have checked the tyre load index
  - FSM-LUB** Lubricated rear shackles on front suspension pins and bushings
  - FSTAB** Front anti-roll bar
  - FSTAB2** Front anti-roll bar medium stiffness
  - FSTAB3** Front stiff anti-roll bar
  - RAL27** Rear bogie design capacity 27 tonnes
  - RAL30.5** Rear bogie design capacity 30.5 tonnes
  - RAL32** Rear bogie design capacity 32 tonnes
  - RAL35** Rear bogie design capacity 35 tonnes
  - RSTAB3** Rear stiff anti-roll bar
  - RALIM105** Rear axle load limiter, 10.5 tonnes
  - RALIM115** Rear axle load limiter, 11.5 tonnes
  - RALIM13** Rear axle load limiter, 13 tonnes
  - RALIM95** Rear axle load limiter, 9.5 tonnes
  - ACTST-TO** Volvo Dynamic Steering (VDS) with with extra electronic pump and torque overlay
  - ASFE-BAS** Active steering feature - Basic - Volvo Dynamic Steering only
  - ASFE-PS** Active steering feature - Volvo Dynamic Steering with personal settings
  - PSS-DUAL** Dual power steering system
  - PSS-SING** Single power steering system
  - PSP-VAR** Power steering pump with variable displacement

# MODEL RANGE

## FH 16 8x4 Rigid - Pusher Axle Tridem – contact sales engineering reference application

- **EBS-MED** EBS medium package including "hill" hold function
- **AUXPARK** Additional spring parking brakes
- **FRAME300** Frame rail section external height 300 mm
- **FST7070** Frame thickness - web and flange 7.0mm
- **FST8080** Frame thickness - web and flange 8.0mm
- **FIL-EEEB** Inner liner from end of engine to end of bogie
- **FIL-EEEF** Inner liner from end of engine to end of frame
- **FIL-FBEF** Inner liner from front of bogie to end of frame
- **FIL-TXEB** Inner liner from gearbox member to end of bogie
- **FIL-TXEF** Inner liner from gearbox member to end of frame
- **BBOX-L** Battery box located on left hand side
- **BATS-D** Dual energy battery system - 2 living batteries and 2 starter batteries.
- **BATS-S** Single energy battery system (2 batteries)
- **2BAT210B** 2 x 210 Ah capacity Gel batteries
- **2BATT225** 2 x 225 Ah capacity batteries
- **BATTAMP** Battery voltage and ampere gauge
- **BATTIND** Battery charge indication
- **ADR2** ADR package for transportation of dangerous goods on road (Note does NOT include safe loading pass package if required this is quoted seperately)
- **MSWI-A** Main switch - ADR switch circuit shut down
- **MSWI-C** Main switch - Chassis mounted toggle switch by battery box
- **MSWI-R** Main switch - Key fob operated remote controlled
- **R330A71** Right aluminium 710 mm D-shaped fuel tank, 330 litres volume  
Min volume 210l  
Max volume 810l
- **UL-FUEL** Without left fuel tank  
Min volume 160l  
Max volume 690l
- **ADTP-L** AdBlue tank on left hand side
- **ADTP-R** AdBlue tank on right hand side
- **ADB048** AdBlue tank usable volume 48 litres
- **ADB064** AdBlue tank usable volume 64 litres
- **ADB068** AdBlue tank usable volume 68 litres
- **ADB090** AdBlue tank usable volume 90 litres
- **ADB100** AdBlue tank usable volume 100 litres
- **ADTC-BF** AdBlue tank cover with satin alloy look decorative cover
- **FCAP-L** Locking fuel filler cap
- **FUFF-AS** Fuel filling anti-spillage device
- **FUFF-ATS** Fuel filling anti-theft and anti-spillage devices
- **ESH-LEFT** Horizontal silencer, left exhaust outlet
- **ESH-REAR** Horizontal silencer, rear exhaust outlet
- **ESH-RIGH** Horizontal silencer, right exhaust outlet
- **ESH-VERT** Horizontal silencer, vertical exhaust outlet
- **EXST-SSP** Stainless steel exhaust stack - NOT polished
- **EXST-ST** Steel exhaust stack
- **HS-NAR** Narrow heat shield
- **WHC-FIX2** Two fixed wheel chocks
- **WHC-FOL2** Two foldable wheel chocks
- **WHCP-F** Wheel chock(s) stored in the front part of the vehicle
- **WHCP-M** Wheel chock(s) stored in the middle part of the vehicle
- **WHCP-R** Wheel chock(s) stored in the rear part of the vehicle
- **WHCP-T** Transport mounted wheel chock(s) stored in cab outer luggage locker
- **TB-R80** Toolbox 800 mm, right side
- **SUP-BAS** EC approved chassis side guards
- **CHAIN-S** Snow chains
- **HOOK-SC** Snow chain hooks
- **TOWF-NO1** One front towing device
- **TOWF-NO2** Two front towing devices
- **TOWMBRH** Towing member, high mounted in centre of frame, D = 190
- **TOWMBRL1** Towing member, low mounted under the frame
- **TOWMBRM** Towing member, medium mounted in line with frame lower flange
- **RFEC-S** Rear frame end, straight cut for regular platform applications
- **RFEC-U** Rear frame end, upper cut for tipper applications.
- **C-RI4040** Towing coupling, Ringfeder 4040 G-150
- **C-RI5055** Towing coupling, Ringfeder 5055 G-150
- **C-RO400G** Towing coupling, Rockinger 400 G-150 for 40mm eyes
- **C-RO50** Rockinger RO 50 50mm for centre axle trailer
- **TOWR-ONE** Towing hitch attached to rear crossmember
- **TREL-PK** Trailer electrical preparation kit - chassis/cab wiring
- **TREL14** Single 14 pole electrical trailer connector
- **TREL15** Single 15 pole electrical trailer connector - ADR certified
- **TREL7** 7 pole - 24N trailer electrical suzie
- **TREL7-7** 24N and 24S trailer electrical suzies
- **TBC-DUO** Duomatic type air line connectors
- **TBC-EC** Palm coupling type air line connectors
- **TRBR-HCF** Full pressure hand controlled trailer brake
- **TRBR-STA** Stationary trailer brake control
- **TRB-STRE** Stretch Brake - Automatic low speed trailer brake activation to avoid jack-knifing and improve steerability
- **RUP-FOSL** Folding & sliding EC approved aluminium rear underrun
- **RFEND-B** Three piece EC approved rear mud wings and spray flaps
- **RFEND-T** Rear mud wings, transport mounted
- **RFH-BAS** Basic rear wing height
- **RFH-HIG** High rear wing height - higher wing tops
- **RFH-LOW** Lower rear wing height - shallower wing tops
- **ATANK-AL** Aluminium air tanks
- **ATANK-ST** Steel air tanks
- **TL-LED** Rear lights LED
- **BLIGHT-E** Emergency brake light

### WHEELS & TYRES

- **RT-AL** Alcoa brushed aluminium rims with standard holes for long stud fixing on all axles
- **RT-ALDP** Alcoa Dura-Bright EVO aluminium rims with standard holes long stud fixing on all axles, requires cleaning with a ph neutral solution - washing up liquid.
- **RT-ALDPD** Alcoa Dura-Bright EVO aluminium rims with countersunk holes for short stud fixing on all axles, requires cleaning with a ph neutral solution - washing up liquid.
- **RT-ALDU** Alcoa brushed aluminium rims with countersunk holes for short stud fixing on all axles
- **RT-STEEL** Steel rims on all axles
- **WCAP** Aerodynamic hub caps
- **SPWT-D** Spare wheel & tyre with rear tyre pattern
- **SPWT-F** Spare wheel & tyre with front tyre pattern
- **SWCP-LF** Spare wheel carrier on left side of chassis ahead of rear axle
- **SWCP-R** Rear mounted spare wheel carrier
- **SWCP-T** Spare wheel supplied temporarily strapped to chassis
- **SWCP-TP** Temporary spare wheel carrier on top of chassis frame
- **JACK-12T** 12 tonne bottle jack
- **JACK-15T** 15 tonne bottle jack
- **JACK-20T** 20 tonne bottle jack
- **TOOL-BAS** Basic Toolkit
- **TOOLKIT** Complete tool kit
- **INFLAHOS** Tyre inflation hose
- **GAUGE-TP** Tyre pressure gauge

### DRIVELINE EQUIPMENT

- Standard Equipment
- Optional Equipment

For more detailed information about cab and powertrain equipment, please refer to separate specification sheets.

For all possible options and combinations of options please consult your Volvo sales contact who can create a specification to match your requirements using the Volvo Sales Support system (VSS).

The factory reserves the right to modify design and change equipment without previous notification. The specification can vary from country to country.

# MODEL RANGE

## FH 16 8x4 Rigid - Pusher Axle Tridem – contact sales engineering reference application

- |  |   |
|--|---|
| <ul style="list-style-type: none"> <li><input type="checkbox"/> <b>ASO-C</b> Crawler gear -<br/>Ratio direct top gearbox 19:1<br/>Ratio Overdrive gearbox 17:1</li> <li><input type="checkbox"/> <b>ASO-ULC</b> Ultra low crawler and crawler gear -<br/>Ratios direct top gearbox 32:1 and 19:1<br/>Ratios Overdrive box 32:1 and 17:1</li> <li>■ <b>TRAP-HD</b> Reinforced gearbox application</li> <li><input type="checkbox"/> <b>TP-CON</b> Construction Package</li> <li><input type="checkbox"/> <b>TP-DIST</b> Distribution Package</li> <li><input type="checkbox"/> <b>TP-HD</b> I-shift software - Heavy duty for high GCW<br/>Special conditions apply consult Sales Engineering</li> <li><input type="checkbox"/> <b>TP-LONG</b> Long Haul Package</li> <li><input type="checkbox"/> <b>AMSO-AUT</b> Enhanced I-shift software with manual shift available in auto mode and kickdown facility on accelerator pedal</li> <li><input type="checkbox"/> <b>AVO-ENH</b> Enhanced software for off road driveability and starting</li> <li><input type="checkbox"/> <b>APF-ENH</b> I-shift enhanced PTO functions</li> <li><input type="checkbox"/> <b>CD43-O</b> Dual plate clutch, plate diameter 430 mm</li> <li><input type="checkbox"/> <b>RET-TH</b> Gearbox mounted retarder</li> <li><input type="checkbox"/> <b>TC-MAOH2</b> Extra high performance transmission oil cooler - air to oil with front mounted radiator</li> <li><input type="checkbox"/> <b>TC-MWO</b> Basic transmission oil cooler - water to oil</li> <li><input type="checkbox"/> <b>2COM1100</b> Two cylinder, air compressor, 1100 litres per minute</li> <li>■ <b>2COMP900</b> Two cylinder, air compressor, 900 litres per minute</li> <li><input type="checkbox"/> <b>CLU-AIRC</b> Clutchable air compressor</li> <li><input type="checkbox"/> <b>AIRIN-FR</b> Front air intake fitted to the underside of cab engine tunnel</li> <li>■ <b>AIRIN-HI</b> Roof mounted air intake behind cab on left hand side</li> <li><input type="checkbox"/> <b>AIRIN-LO</b> Low level air intake behind cab on left hand side</li> <li><input type="checkbox"/> <b>ACL1ST-S</b> Two stage air filter</li> <li>■ <b>24AL120B</b> 120 amp alternator</li> <li><input type="checkbox"/> <b>24AL150B</b> 150 amp alternator</li> <li>■ <b>CCV-C</b> Closed crankcase engine ventilation</li> <li>■ <b>CCV-OX</b> Closed crankcase ventilation for cold markets</li> <li>■ <b>PRIM-EL</b> Electrical priming pump</li> <li><input type="checkbox"/> <b>AF-R</b> Hot fuel recirculation heated fuel filter</li> <li><input type="checkbox"/> <b>FUEFE2LW</b> Large engine mounted dual fuel filter with water separator</li> <li>■ <b>FUEFE2SW</b> Small engine mounted dual fuel filter with water separator</li> <li><input type="checkbox"/> <b>EST-AID</b> Air inlet manifold starting heater element</li> <li><input type="checkbox"/> <b>220EBH15</b> 220V/1.5Kw electric engine block heater</li> <li><input type="checkbox"/> <b>PTER-100</b> Rear engine mounted power-take-off with DIN 100 / ISO 7646 flange</li> <li><input type="checkbox"/> <b>PTER-DIN</b> Rear engine mounted PTO with DIN5462 (female) splined shaft for a close coupled pump.<br/>Models with 3 steering axles will use this to drive the steering pump (AUXPSP)</li> <li><input type="checkbox"/> <b>PTER1400</b> Rear engine mounted power-take-off with SAE 1410 flange</li> <li><input type="checkbox"/> <b>HPE-F101</b> Parker F1-101, engine mounted, fixed displacement, single flow, engine mounted hydraulic pump</li> <li><input type="checkbox"/> <b>HPE-F41</b> Parker F1-41, engine mounted, fixed displacement, single flow, engine mounted hydraulic pump</li> <li><input type="checkbox"/> <b>HPE-F51</b> Parker F1-51, engine mounted, fixed displacement, single flow, engine mounted hydraulic pump</li> <li><input type="checkbox"/> <b>HPE-F61</b> Parker F1-61, engine mounted, fixed displacement, single flow, engine mounted hydraulic pump</li> <li><input type="checkbox"/> <b>HPE-F81</b> Parker F1-81, engine mounted, fixed displacement, single flow, engine mounted hydraulic pump</li> <li><input type="checkbox"/> <b>HPE-T53</b> Parker F2-53/53, engine mounted, Fixed displacement, Twin flow engine mounted hydraulic pump</li> <li><input type="checkbox"/> <b>HPE-T70</b> Parker F2-70/35, engine mounted, Fixed displacement, Twin flow engine mounted hydraulic pump</li> <li><input type="checkbox"/> <b>HPE-V45</b> Parker VP1-45, variable displacement, single flow, engine mounted hydraulic pump</li> <li><input type="checkbox"/> <b>HPE-V75</b> Parker VP1-75, variable displacement, single flow, engine mounted hydraulic pump</li> </ul> | <ul style="list-style-type: none"> <li><input type="checkbox"/> <b>PTR-D</b> Gearbox PTO for plug-in pump, 0.71xeng speed</li> <li><input type="checkbox"/> <b>PTR-DH</b> Gearbox driven high speed PTO for one plug-in hydraulic pump</li> <li><input type="checkbox"/> <b>PTR-DM</b> Gearbox driven medium speed PTO for one plug-in hydraulic pump</li> <li><input type="checkbox"/> <b>PTR-F</b> Gearbox driven PTO with rear flange connection</li> <li><input type="checkbox"/> <b>PTR-FH</b> Gearbox driven high speed PTO with SAE drive flange</li> <li><input type="checkbox"/> <b>PTR-FL</b> Gearbox driven low speed PTO with SAE drive flange</li> <li><input type="checkbox"/> <b>PTRD-D</b> Gearbox driven HIGH SPEED PTO for two plug-in hydraulic pumps</li> <li><input type="checkbox"/> <b>PTRD-D1</b> PTRD-D1 Gearbox driven HIGH SPEED PTO (1 SAE flange &amp; 1 plug-in hydraulic pump)</li> <li><input type="checkbox"/> <b>PTRD-D2</b> Gearbox driven HIGH SPEED PTO (2 SAE flanges &amp; 1 plug-in hyd pump)</li> <li><input type="checkbox"/> <b>PTRD-F</b> PTO with 1 DIN + 1 flange connection rear, manual gearbox</li> <li><input type="checkbox"/> <b>HPG-F101</b> Parker F1-101 gearbox mounted, fixed displacement, single flow, hydraulic pump</li> <li><input type="checkbox"/> <b>HPG-F41</b> Parker F1-41 gearbox mounted, fixed displacement, single flow, hydraulic pump</li> <li><input type="checkbox"/> <b>HPG-F51</b> Parker F1-51 gearbox mounted, fixed displacement, single flow, hydraulic pump</li> <li><input type="checkbox"/> <b>HPG-F61</b> Parker F1-61 gearbox mounted, fixed displacement, single flow, hydraulic pump</li> <li><input type="checkbox"/> <b>HPG-F81</b> Parker F1-81 gearbox mounted, fixed displacement, single flow, hydraulic pump</li> <li><input type="checkbox"/> <b>EIDLES</b> Engine idle shut down</li> <li><input type="checkbox"/> <b>DTRI-PER</b> Dashboard in darker peregrine greyish brown. Steering wheel grey and door panels in light beige for FH and black for FH16.</li> <li><input type="checkbox"/> <b>DTRI-SRA</b> Dashboard and steering wheel cover in light beige skylark. Door panels in light beige for FH and black for FH16.</li> <li>■ <b>STWPOS-R</b> RIGHT HAND DRIVE</li> <li>■ <b>STWM-LE</b> Leather steering wheel</li> <li><input type="checkbox"/> <b>STGW-AD2</b> Adjustable steering wheel with neck tilt</li> <li>■ <b>STGW-ADJ</b> Adjustable steering wheel</li> <li>■ <b>AIRBAG</b> SRS Driver's air bag</li> <li>■ <b>DRC-AMII</b> DPF Regeneration control switch - for manual and switching off regeneration</li> <li>■ <b>1DAYDIG2</b> Continental VDO DTCO 4.0 smart tachograph<br/>This tachograph can ONLY offer remote download if the option of Dynafleet or an FMS gateway has been specified with this order.</li> <li><input type="checkbox"/> <b>1DAYDIGP</b> Continental VDO DTCO 3.0 digital tachograph<br/>For vehicles with long lead time - this includes prep kit for the retrofit of DTCO 4.0 tachograph.<br/>For updating to new legal demand for trick registration from 15th June 2019.<br/>This tachograph can ONLY offer remote download if the option of Dynafleet or an FMS gateway has been specified with this order.</li> <li><input type="checkbox"/> <b>ARSL</b> Additional road speed limit - switch in dashboard</li> <li><input type="checkbox"/> <b>CRUIS-E</b> Eco cruise control (with eco-roll and I-cruise, controls in steering wheel)</li> <li>■ <b>CRUISEC</b> Cruise control, standard</li> <li><input type="checkbox"/> <b>ESP-BAS1</b> Electronic Stability Control</li> <li><input type="checkbox"/> <b>ESPC-RO</b> ESP (Electronic Stability Program) functionality control - Reduced / Off</li> <li><input type="checkbox"/> <b>HWSS-ACB</b> Adaptive cruise control ACC with forward collision warning and AEBS advanced emergency brake system</li> <li><input type="checkbox"/> <b>HWSS-FCB</b> Forward collision warning with AEBS advanced emergency brake system</li> <li><input type="checkbox"/> <b>LSS-DW</b> Lane departure-warning system</li> <li><input type="checkbox"/> <b>LCS</b> Lane change support</li> <li><input type="checkbox"/> <b>DAS-W</b> Driver Alert Support system</li> </ul> |
|--|---|
- Standard Equipment      □ Optional Equipment

For more detailed information about cab and powertrain equipment, please refer to separate specification sheets.

For all possible options and combinations of options please consult your Volvo sales contact who can create a specification to match your requirements using the Volvo Sales Support system (VSS).

The factory reserves the right to modify design and change equipment without previous notification. The specification can vary from country to country.

# MODEL RANGE

## FH 16 8x4 Rigid - Pusher Axle Tridem – contact sales engineering reference application

<input type="checkbox"/> <b>RSENS-W</b>	Rain sensing windscreen wipers	<input type="checkbox"/> <b>DST-LUX1</b>	Deluxe suspended drivers seat features: electrical adjustment with memory function, seatbelt in seat with heated & ventilated cushions
<input checked="" type="checkbox"/> <b>CU-ECC</b>	Electrically controlled air conditioning with sun sensor	<input type="checkbox"/> <b>DST-LUX2</b>	Deluxe suspended drivers seat features: electrical adjustment with memory function, seatbelt in seat and heated cushions
<input type="checkbox"/> <b>CU-ECC2</b>	Electrically controlled air conditioning with sun sensor, mist sensor, air quality sensor and carbon filter	<input type="checkbox"/> <b>SBD-RED</b>	Red seat belts
<input checked="" type="checkbox"/> <b>IMMOBIL</b>	Thatcham H2 approved immobiliser	<input type="checkbox"/> <b>SBPRE-DS</b>	Driver seat belt pretensioner
<input type="checkbox"/> <b>ALARM-B</b>	Thatcham H1 approved vehicle alarm - Cab only	<input type="checkbox"/> <b>PST-BAS1</b>	Passenger seat - Fixed non suspended fold up with seatbelt mounted in cab
<input type="checkbox"/> <b>ALARM-E</b>	Enhanced vehicle alarm - Thatcham H1 approved - Cab plus external sensor for body/trailer	<input type="checkbox"/> <b>PST-BSL1</b>	Passenger seat - Sliding non suspended fold up with seatbelt mounted in cab
<input type="checkbox"/> <b>ALCOLOCK</b>	Alcolock	<input type="checkbox"/> <b>PST-CF4</b>	Passenger seat - Comfort suspended with seatbelt mounted in seat
<input type="checkbox"/> <b>AMPL400</b>	Radio amplifier, 8 channel, 400 W with subwoofer Located in right hand external storage box	<input type="checkbox"/> <b>PST-CF5</b>	Passenger seat - Comfort suspended & heated with seatbelt mounted in seat
<input type="checkbox"/> <b>BUPMON</b>	Back up monitor with built in 7" screen on dash and one colour camera supplied loose for fitment by bodybuilder. Can accommodate up to 4 cameras for TFL Safe Scheme, CLOCS and FORS.	<input type="checkbox"/> <b>PST-RX1</b>	Passenger seat - Fixed non suspended, features: 90 degree rotation and tilt function with seatbelt mounted in cab
<input type="checkbox"/> <b>PHONE-PK</b>	Telephone preparation kit (antenna, antenna attachm. cable incl.)	<input type="checkbox"/> <b>PST-RX2</b>	Passenger seat - Fixed non suspended, features: 90 degree rotation, tilt and heated functions with seatbelt mounted in cab
<input checked="" type="checkbox"/> <b>WLIFT-AD</b>	Electrical window lift, automatic up/down driver side	<input type="checkbox"/> <b>PST-STD2</b>	Passenger seat - Fixed non suspended with seatbelt mounted in cab
<input type="checkbox"/> <b>ISUNS-BS</b>	Side interior sun visor on both sides	<input checked="" type="checkbox"/> <b>PST-STD4</b>	Passenger seat - Standard suspended with seatbelt mounted in cab
<input checked="" type="checkbox"/> <b>ISUNS-DS</b>	Driver's side interior sun visor	<input type="checkbox"/> <b>SBPRE-PS</b>	Passenger seat belt pretensioner
<input type="checkbox"/> <b>ISUNF-RE</b>	Electrically operated textile interior sun blind	<input checked="" type="checkbox"/> <b>ARMRE-BB</b>	Two armrests on both driver and passenger seat.
<input checked="" type="checkbox"/> <b>ISUNF-RM</b>	Manually operated textile interior sun blind	<input checked="" type="checkbox"/> <b>ARU-LEA</b>	Leather upholstered armrest
<input checked="" type="checkbox"/> <b>CSPL-BX</b>	Lower center dash open storage box	<input checked="" type="checkbox"/> <b>GRABHI-L</b>	Leather covered instep cab grab handle
<input type="checkbox"/> <b>CSPL-BXD</b>	Lower centre dash drawer	<input type="checkbox"/> <b>FMAT-RUB</b>	Rubber floor mats
<input type="checkbox"/> <b>CSPU-SDR</b>	One open storage and one drawer - behind push open lid - in upper part of the centre dash panel	<input checked="" type="checkbox"/> <b>FMAT-TX2</b>	Textile and rubber floor mats
<input checked="" type="checkbox"/> <b>CSPU-SS</b>	Two open storages - behind push open lid in upper part of the centre dash panel	<input checked="" type="checkbox"/> <b>LBK80F</b>	Lower fixed bunk with wide middle section 815 in the centre x 2000 mm
<input type="checkbox"/> <b>ADFS</b>	Two extra DIN slots in front shelf - can be fitted with card or drawer available as an accessory	<input type="checkbox"/> <b>LBK80FRE</b>	Lower electrically operated recline bunk with wide middle section 815 in the centre x 2000 mm
<input checked="" type="checkbox"/> <b>BUPALARM</b>	Reverse alarm	<input type="checkbox"/> <b>LBK80FRM</b>	Lower manually operated recline bunk with wide middle section 815 in the centre x 2000 mm
<input type="checkbox"/> <b>RTOLL-PK</b>	Road toll PREPARATION kit for trucks operating with "Toll Collect" in Germany	<input type="checkbox"/> <b>MATL-FI</b>	Firm lower bunk pocket sprung mattress
<input type="checkbox"/> <b>LOADIND</b>	Load indicator with central dashboard display	<input checked="" type="checkbox"/> <b>MATL-SF</b>	Lower flexizone mattress - semi-firm, pocket springs up to 100kg - 16 stone
<input type="checkbox"/> <b>REMC-MF</b>	Multi-functio wireless remote control	<input type="checkbox"/> <b>MATL-SO</b>	Lower flexizone mattress - soft, pocket springs up to 85kg - 13.5 stone
<input type="checkbox"/> <b>FIREXT3S</b>	3kg fire extinguisher mounted on seat base	<input type="checkbox"/> <b>OLMAT-BA</b>	35mm mattress overlay protector
<input type="checkbox"/> <b>WARNVEST</b>	High visibility warning vest - no sleeves	<input checked="" type="checkbox"/> <b>OLMAT-PR</b>	50mm premium mattress overlay protector
<input type="checkbox"/> <b>AIDKIT</b>	First aid kit	<input type="checkbox"/> <b>TBK60AD</b>	Height adjustable foldable top bunk 600 x 1900mm
<input type="checkbox"/> <b>AIDKIT1B</b>	First aid kit	<input type="checkbox"/> <b>TBK60F</b>	Fixed foldable top bunk 600 x 1900mm
<input type="checkbox"/> <b>WARNLAMP</b>	Portable warning lamp	<input type="checkbox"/> <b>TBK70AD</b>	Height adjustable foldable top bunk 700 x 1900mm
<input type="checkbox"/> <b>LAMP-IN</b>	Inspection lamp	<input type="checkbox"/> <b>TBK70F</b>	Fixed foldable top bunk 700 x 1900mm
<input type="checkbox"/> <b>BULBKIT</b>	Bulb and fuse kit	<input type="checkbox"/> <b>PH-CAB2</b>	1.8kW Air to air night heater
<input checked="" type="checkbox"/> <b>WRITEPAD</b>	Writing pad	<input type="checkbox"/> <b>PH-ENGCA</b>	Engine and cab night heater
<input type="checkbox"/> <b>UPHTRI04</b>	Interior trim: Seats: Black/green textile insert, black leather bolster & green/yellow leather side insert Cab walls: Soft textile with matching grey, green and black colours	<input checked="" type="checkbox"/> <b>SLCP-BAS</b>	Basic sleeper control panel - includes interior light, parking heater, roof hatch and door lock
<input type="checkbox"/> <b>UPHTRI05</b>	Interior trim: Seats: Light grey leather insert and black leather bolster Cab walls: In matching grey vinyl	<input type="checkbox"/> <b>SLCP-LUX</b>	Luxury sleeper control panel - includes interior light, parking heater, roof hatch, door lock, alarm clock, window and radio
<input type="checkbox"/> <b>UPHTRI08</b>	Interior trim: Seats: Black with green perforated leather insert and yellow side edging Cab walls: Soft textiles in matching grey, green and black	<input type="checkbox"/> <b>SAFE</b>	Safe box for driver's personal items
<input checked="" type="checkbox"/> <b>DST-CF4</b>	Driver seat, comfort, suspended, belt in seat	<input type="checkbox"/> <b>RUS-BAS</b>	Rear cab upper storage 154 litres - 300 mm high
<input type="checkbox"/> <b>DST-CF5</b>	Driver seat, comfort, suspended, belt in seat, electrically heated	<input type="checkbox"/> <b>RUS-HIG</b>	Rear cab upper storage 245 litres - 440 mm high
<input type="checkbox"/> <b>DST-CF6</b>	Driver seat, comfort, suspended, belt in seat, electrically heated, ventilated	<input type="checkbox"/> <b>TABLE</b>	Folding and height adjustable table - on lower bunk
		<input type="checkbox"/> <b>REFR-RUS</b>	Fridge: 28 litre rear upper wall mounted with dividers
		<input type="checkbox"/> <b>REFRIG</b>	Fridge: 33 litre under bunk mounted with freezer dividers
		<input type="checkbox"/> <b>MICRO-PK</b>	Preparation kit for microwave oven (wiring)
		<input type="checkbox"/> <b>BOTH-D</b>	One bottle holder under dashboard centre section
		<input type="checkbox"/> <b>BOTH-DL</b>	Two bottle holders, one under dashboard centre section and one mounted to the under bunk drawer
		<input type="checkbox"/> <b>BOTH-L</b>	One bottle holder mounted to the under bunk drawer
<input checked="" type="checkbox"/> <b>Standard Equipment</b>		<input type="checkbox"/> <b>Optional Equipment</b>	

For more detailed information about cab and powertrain equipment, please refer to separate specification sheets.

For all possible options and combinations of options please consult your Volvo sales contact who can create a specification to match your requirements using the Volvo Sales Support system (VSS).

The factory reserves the right to modify design and change equipment without previous notification. The specification can vary from country to country.

# MODEL RANGE

## FH 16 8x4 Rigid - Pusher Axle Tridem – contact sales engineering reference application

- COFMA-PK** Coffee maker, preparation kit.
  - INLI-BAS** Interior white LED lights - basic
  - INLI-NL** Interior white and red night LED light with no dimmer
  - INLI-NLD** Interior white and red night LED light with dimmer
  - ARL-FLEX** Two flexible reading lamps (snake lamps)
  - RH-EE** Without roof hatch -Tinted glass emergency exit ONLY
  - RH-ETR** Glass roof & escape hatch - Electrically operated, tinted glass with rear opening
  - RH-MTR** Glass roof & escape hatch - Manually operated, tinted glass with rear opening
  - URH** Without roof hatch
  - SWIND-BS** Extra side window on both sides behind "B" pillar
  - VANMIR** Vanity mirror in front shelf
  - AS-FUS** Extra shelf in front upper storage compartments
  - INFOT-PK** Preparation kit for the mounting of a flat screen TV in cab above the driver's door, includes bracket, electrical and speaker connections
- ### CAB EXTERIOR
- EXTL-BAS** Basic exterior finish - - Matt Volvo badges, grey instep, bumper, bumper spoiler, mirror housing and sun visor
  - EXTL-ENH** Enhanced exterior finish - Chrome style Volvo badges, painted instep, bumper, bumper spoiler if specified, mirror housing and sun visor
  - GLAS-TIN** Tinted windows.
  - DGLAS-H** Tempered door glass
  - DGLAS-L** Laminated door glass
  - LOCK-REM** Central locking with remote control
  - BUMP-B** Plastic front bumper
  - BUMP-B2** Steel front bumper
  - BUMP-HD** Heavy duty front bumper
  - BUMP-SP** Front bumper spoiler
  - GUARD-EH** Engine guard to protect sump and engine hoses
  - BUGNET** Insect screen in front of radiator
  - CTILT-P-E** Electrically operated hydraulic cab tilt
  - CTILT-P-M** Manually operated hydraulic cab tilt
  - FCABS-A** Front cab suspension - Air
  - FCABS-M** Front cab suspension - Mechanical spring
  - RCABS-A** Rear cab suspension - Air
  - RCABS-M** Rear cab suspension - Mechanical spring
  - HCC-INEX** Exterior and interior hood catch control
  - MIRCOMF** Electrically heated and operated main and wide angle mirrors and manually adjusted kerb view mirror on passenger side
  - MIRSTD** Electrically heated main and wide angle mirrors and manually adjusted kerb view mirror on passenger side
  - AMIR-F20** Auxiliary front view mirror with a 200mm radius
  - SUNV-H** External smoke grey sunvisor
  - AD-ROOF** Roof air deflector
  - AD-SIDES** Short cab side air deflector for rigid bodywork
  - HL-BASIC** Halogen H7 head lamps
  - HL-BHID** High intensity Bi-Xenon head lamps
  - HL-DBL** Bi-Xenon high intensity discharge and dynamic head lamps. Dipped beam follows the road, activated by a signal from the steering system.
  - HL-CLEAN** Head lamp cleaner - washer jets
  - HLP-ST** Headlamp protection
  - HL-ADJ** Headlight adjustment - Switch in cab
  - DRIVL2** Two spot lamps
  - UDRIVL** Without auxiliary driving lights
- FOGL-WC** Front fog lights
  - CL-STAT** Static corner lights
  - ASL-RF2** Two Hella H11 70W spotlamps in sign box - only available with the basic headlight and no lower driving lights.
  - BEACOA2F** Two front roof mounted amber beacon rotating warning lamps
  - BEACOA2R** Two rear roof mounted (on accessory bracket) amber beacon flashing warning LED lamps
  - BEACON-P** Roof beacon wire preparation
  - BEACONA4** Four roof mounted (2 front/2 rear) amber beacon rotating warning lamps
  - CABPT-R1** Single outlet for roof mounted accessories
  - CABPT-R2** Twin outlets for roof mounted accessories.
  - SPOTP-F** Spotlamp preparation in front, max 280W
  - SPOTP-R** Spotlamp preparation on roof, max 280W
  - SPOTP-RF** Spotlamp preparation on cab roof and in cab front, max 2x280W
  - ROS-IL2** Preparation kit for illuminated roof sign with switch loose in cab, fit after registration
  - CSGN-ENG** Engine size and power headboard logo
  - CSGN-GTR** "Globetrotter" headboard logo
  - HORN-F1S** Single tone Jericho air horn chassis mounted
  - HORN-R2S** Two roof mounted air horns
  - ANT-CBR** Roof mounted antenna for CB radio, single aerial
  - ACCB-R-AP** Front, middle & rear roof mounted accessory brackets
  - ACCB-R-F** Front roof mounted accessory bracket
  - ACCB-R-FM** Front & middle roof mounted accessory brackets
  - ACCB-R-FR** Front & rear roof mounted accessory brackets
  - ACCB-R-M** Middle roof mounted accessory bracket
  - ACCB-R-R** Rear roof mounted accessory bracket
  - ACCB-R-RM** Rear & middle roof mounted accessory brackets
  - STUC-B** Left and right storage compartments under cab
  - STUC-L** Left storage compartment under cab
  - STUC-R** Right storage compartment under cab
  - REFS-TW** White cab conspicuity markings by packed in cab
  - REFS-TY** Yellow cab conspicuity markings by packed in cab
- ### SUPERSTRUCTURE PREPARATIONS
- SRWL-PK** Wiring preparation for side & rear work/reverse lamps on side of chassis and a three-position switch, maximum 280W
  - SWL-2FW** Two H3 70W white front chassis mounted (LH/RH side) working lamps and a 2-position switch (On/Off)
  - SWL-2RW** Two H3 70W white rear chassis mounted (LH/RH side) working lamps and a 2-position switch (On/Off)
  - SWL-4W** 4 H3 70W white front (2) & rear (2) chassis mtd (LH/RH side) working lamps & 2-pos switch (On/Off)
  - SWL-PK** Wiring preparation for side work/reverse lamps on side of chassis and a three-position switch, maximum 280W
  - WLC-H2W** Two H3/70W white working lamps high mounted on the back of cab
  - WLC-PKCH** Preparation kit (cables and switch) for cab mounted chassis working lamp
  - WLC-PKH** Preparation kit, cables and switch for high mounted working lamps back of cab
  - WLC-PKL** Preparation kit, cables and switch for low mounted working lamps back of cab
  - WLC-PKLH** Preparation kit - cables and switch for low and high mounted working lamps back of cab.
  - ECBB-BAS** Body builder electrical centre without body builder module
  - ECBB-HIG** Body builder electrical centre with body builder module
  - BBCHAS1** One 7-pole connector for Body builder interface
  - BBCHAS3** Three 7-pole connectors for Body builder interface
  - BEPR-T2** Body builder electrical software preparation for tipper with remote control
  - EXSTER** External steering control, with VDS and bodybuilder module

■ Standard Equipment      □ Optional Equipment

For more detailed information about cab and powertrain equipment, please refer to separate specification sheets.

For all possible options and combinations of options please consult your Volvo sales contact who can create a specification to match your requirements using the Volvo Sales Support system (VSS).

The factory reserves the right to modify design and change equipment without previous notification. The specification can vary from country to country.

# MODEL RANGE

## FH 16 8x4 Rigid - Pusher Axle Tridem – contact sales engineering reference application

---

- **TD-LED** Trailer detection with LED sensing
- **FRFS-BS** Frame rail free space on both sides to give space for crane legs or other equipment.
- **FBA-BTF** Lower front body attachments for torsionally flexible - platform body
- **FBA-BTSF** Lower front body attachments for torsionally semi-flexible body - box or curtainsider
- **HBA-FSFB** Holes for body attachments - flexible/semi-flexible body
- **HBA-SB** Holes for body attachments - stiff body
- **RBA-T2** Lower rear body attachments for helper frame
- **CRANEPK1** Crane plates mounted to frame, for cranes up to 10 tonne metre capacity
- **CRANEPK2** Crane plates mounted to frame, for cranes up to 20 tonne metre capacity
- **CRANEPK4** Crane plates mounted to frame, for cranes up to 40 tonne metre capacity
- **AUXL-SPK** Electrical preparation kit - wiring and switch for snow plough lights
- **TAILPRE2** Tail lift preparation kit, wireless remote operation
- **TAILPREP** Taillift preparation kit - cab switch and warning in driver display
- **AESW2** Two Body builder bistable electrical switches (marked AUX1 / AUX2)
- **AESW2PK** 2 Body builder bistable el.switches (marked AUX1/AUX2) and prep. for 4 more switches
- **AUXSW-4** Wiring for 4 extra switches (from Body builder electrical centre to switch positions)

### DELIVERY SERVICES

- **TGW-4GWL** GSM/GPRS/4G modem, LTE & WLAN for telematics gateway
- **FMS-PK** Fleet Management System gateway

**VOLVO**

Volvo Truck Corporation  
volvotrucks.com