

MODEL RANGE

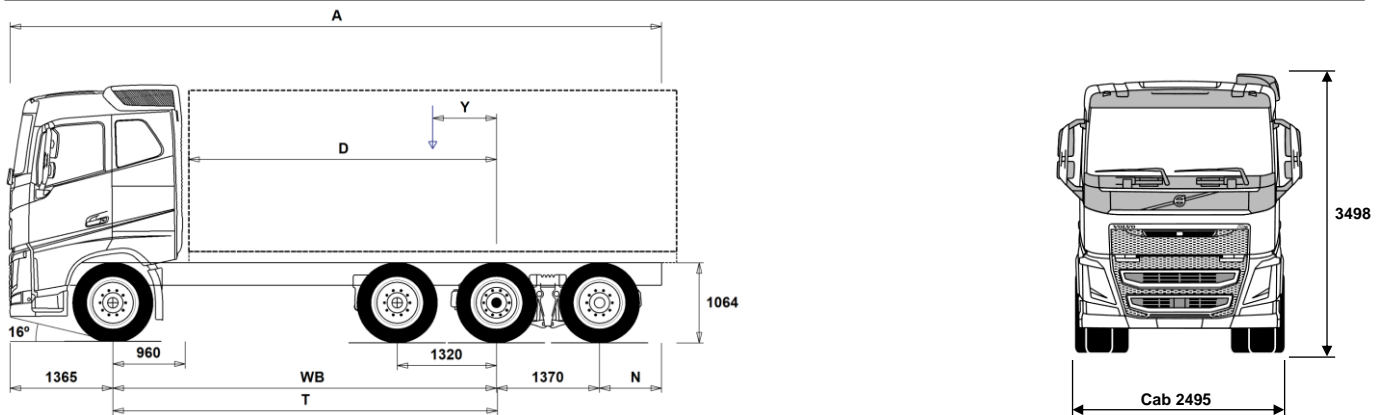

Volvo Trucks. Driving Progress

FH 16 8x2 Rigid - Pusher Axle Tridem – contact sales engineering reference application



Chassis Dimensions [mm]

| WB Wheelbase | 5100 | 5600 |
|--|------|-------|
| A Overall Chassis Length | 9710 | 10110 |
| D Center of rear axle to front of body | 4090 | 4590 |
| N Rear Overhang (Min.) | 825 | 825 |
| N Rear Overhang (Max.) | 1875 | 1775 |
| T Theoretical Wheelbase | 5114 | 5614 |
| Y Center of Gravity for Payload (Min.) | 558 | 606 |
| Y Center of Gravity for Payload (Max.) | 558 | 606 |

Chassis Weights [kg]

| | | |
|--|-------|-------|
| Front Axle | 5445 | 5480 |
| Rear Bogie | 3685 | 3685 |
| Kerb Weight | 9130 | 9165 |
| Payload (including body, driver, fuel, etc.) | 22870 | 22835 |

Turning Diameter [mm]

| | | |
|--------------------------------------|-------|-------|
| Turning Circle Diameter Kerb to Kerb | 20100 | 21700 |
| Turning Circle Diameter Wall to Wall | 21400 | 23100 |

Plated Weights [kg]

| | Plated | Design |
|--------------------------|--------|--------|
| Gross Vehicle Weight | 32000 | 35000 |
| Gross Combination Weight | 44000 | 44000 |
| Front Axle | 8000 | 8000 |
| Rear Bogie | 24000 | 27000 |

Important Notes

Chassis Dimensions

Cab Height: +305 mm for CAB-HSLP, -283 mm for CAB-LSLP, +450 mm for CAB-XHSL.

D-measure includes a front clearance of 50 mm and for rigid trucks also a subframe of 100 mm.

Height can vary ± 20 mm for leaf and ± 10 mm for air suspension.

All dimensions are for unladen chassis and any tag axles down. Chassis height used: CHH-HIGH.

Rear overhang used for vehicle weight calculation is the maximum rear overhang (N Max.) for selected wheelbase.

Height change when chassis height CHH-MED,FRAME300: 0 mm.

Weight and dimensions are based upon the following tyres:

| | |
|-----------------------------|-------------|
| Front Axle Tyres: | 315/80R22.5 |
| Drive Axle Tyres: | 315/80R22.5 |
| Trailing/Pusher Axle Tyres: | 315/80R22.5 |

Chassis weight includes oil, water, AdBlue, 0 litres fuel and without driver. Kerb weight can vary $\pm 3\%$.

Turning diameters are theoretically calculated. Tag axle used: TA-FIXED.

Legal weights can differ from country to country.

For more detailed weight information, including optional equipment weights, ask your Volvo sales contact to enter your specification into the Volvo Weight Information system (WIS).

Do NOT use this drawing for bodybuilding. Refer to Volvo Bodybuilder Instructions and chassis assembly drawing FH82PTR6HA.

MODEL RANGE

FH 16 8x2 Rigid - Pusher Axle Tridem – contact sales engineering reference application

TRUCK USE

- RC-ROUGH** Operating class on/off road
- RC-SMOOTH** Operating class highway
- TIPP-PRE** Tipper vehicle preparation
- UNIFORM** Basic platform vehicle

CORE COMPONENTS

- CHH-HIGH** Chassis height high - N3 "On Road" chassis - For a specific loading height always check the unique BEP chassis drawing
- CHH-MED** Chassis height medium - For a specific loading height always check the unique BEP chassis drawing
- PT-TEHYS** Pusher-tag tridem - Electro hydraulic steered pusher and tag axle, both with single wheel mounting
- PT-TFIXD** Pusher-tag tridem - Electro hydraulic steered pusher with fixed tag/dual wheel mounting
- RAPDT-GR** Rear air suspension, 3 axles - 1 pusher/1 driven/1 tag
- FH16HSLP** Globetrotter cab - all steel safety cage design with roof mounted emergency escape hatch. Designed and built to Swedish impact and ECE R29 regulations
- FH16SLP** Sleeper cab - all steel safety cage design with roof mounted emergency escape hatch. Designed and built to Swedish impact and ECE R29 regulations
- FH16XHSL** Globetrotter XL cab - all steel safety cage design with roof mounted emergency escape hatch. Designed and built to Swedish impact and ECE R29 regulations
- D16K550** D16K550 16litre engine developing 550hp at 1550-1900rpm SCR & EGR. Peak torque 2900Nm at 900-1350rpm. 2800Nm at 900-1400rpm with manual gearbox
- D16K650** D16K650 16litre engine developing 650hp at 1450-1900rpm SCR & EGR. Peak torque 3150Nm at 950-1450rpm.
- D16K750** D16K750 16litre engine developing 750hp at 1600-1800rpm SCR & EGR. Peak torque 3550Nm at 950-1400rpm.
- EBR-VEB+** Volvo engine brake + and exhaust pressure governor, enhanced performance from additional exhaust rocker control. Retardation 375kW
- AT2812F** AT2812E 12-speed "I-shift" automated mechanical gearbox suitable for gross train weights up to 60 tonne refer to sales engineering when used in conjunction with a PTO
- ATO3112F** ATO3112F 12-speed "I-shift" overdrive automated mechanical gearbox suitable for gross train weights up to 60tonne refer to sales engineering when used in conjunction with a PTO
- ATO3512F** ATO3512F 12-speed "I-shift" automated mechanical gearbox suitable for gross train weights up to 60 tonne refer to sales engineering when used in conjunction with a PTO
- RSH1370F** RSH1370F hub reduction rear axle with differential lock - design GCW 70 tonne
- RSS1370A** RSS1370A single reduction 13 tonne rear axle with differential lock - design GCW 70 tonne
- RSS1370B** RSS1370B single reduction 13 tonne rear axle with differential lock - design GCW 70 tonne

PACKAGES

- LHFP-VE** Long Haul Fuel Economy driving package
- LHFP-VE+** Long Haul Fuel Economy plus driving package
- DRIV16++** Cab Package: Drive ++
- DRIVE16+** Cab Package: Drive +
- 1BED** Living package with single bed:
- 1BED+** Living package with single bed plus:
- 2BED** Living package with two beds:

Standard Equipment

Optional Equipment

For more detailed information about cab and powertrain equipment, please refer to separate specification sheets.

For all possible options and combinations of options please consult your Volvo sales contact who can create a specification to match your requirements using the Volvo Sales Support system (VSS).

The factory reserves the right to modify design and change equipment without previous notification. The specification can vary from country to country.

- 2BED+** Living package with two beds plus:
- AUDHIG** High Power Audio system: RDS radio with CD player - also playing MP3/WMA files from CD -, with integrated bluetooth phone and USB/Line inputs. FM/AM antenna, speakers in dashboard, doors, and sleeping compartment.
- MEDIA** AM/FM Bluetooth radio without CD player. USB and Aux line inputs. Speakers in dashboard, doors, and sleeping compartment. 7" touch screen with personal apps.
- MEDIADF** AM/FM Bluetooth radio without CD player. USB and Aux line inputs. Speakers in dashboard, doors, and sleeping compartment. 7" touch screen with personal and professional apps. Dynafleet vehicle on-board data display with office internet support.
- MEDIANAV** AM/FM Bluetooth radio without CD player. USB and Aux line inputs. Speakers in dashboard, doors, and sleeping compartment. 7" touch screen with personal and professional apps. Truck based satellite navigation (live updates not included)
- MEDIANDF** AM/FM Bluetooth radio without CD player. USB and Aux line inputs. Speakers in dashboard, doors, and sleeping compartment. 7" touch screen with personal and professional apps. Truck based satellite navigation (live updates not included) Dynafleet vehicle on-board data display with office internet support.
- VISI15** Visibility Package
- VISI15+** Visibility Plus Package
- VISIC15** Visibility Package
- RCHAPAC1** Chassis Package Rigid

CHASSIS

- FST-AIR** Front suspension type - air
- FST-PAR** Front suspension type - 2 leaf parabolic springs
- FST-PAR3** Front suspension type - 3 leaf parabolic springs
- FSLB-BAS** Front suspension levelling - basic stroke
- FSLB-HI** Front suspension levelling - high stroke for demount operations - check with bodybuilder
- FAL10.0** Front axle design capacity 10 tonnes - Ensure that you have checked the tyre load index
- FAL8.0** Front axle design capacity 8.0 tonnes - Ensure that you have checked the tyre load index
- FAL8.5** Front axle design capacity 8.5 tonnes
- FAL9.0** Front axle design capacity 9.0 tonnes - Ensure that you have checked the tyre load index
- FSM-LUB** Lubricated rear shackles on front suspension pins and bushings
- FSTAB** Front anti-roll bar
- FSTAB2** Front anti-roll bar medium stiffness
- FSTAB3** Front stiff anti-roll bar
- RAL27** Rear bogie design capacity 27 tonnes
- RAL30** Rear bogie design capacity 30 tonnes
- RAL30.5** Rear bogie design capacity 30.5 tonnes
- RAL31.5** Rear bogie design capacity 31.5 tonnes
- RAL32** Rear bogie design capacity 32 tonnes
- RSTAB3** Rear stiff anti-roll bar
- RALIM105** Rear axle load limiter, 10.5 tonnes
- RALIM115** Rear axle load limiter, 11.5 tonnes
- RALIM13** Rear axle load limiter, 13 tonnes
- ACTST-TO** Volvo Dynamic Steering (VDS) with with extra electronic pump and torque overlay
- ASFE-BAS** Active steering feature - Basic - Volvo Dynamic Steering only
- ASFE-PS** Active steering feature - Volvo Dynamic Steering with personal settings
- PSS-DUAL** Dual power steering system
- PSS-SING** Single power steering system

MODEL RANGE

FH 16 8x2 Rigid - Pusher Axle Tridem – contact sales engineering reference application

- AUXPSP** Extra power steering pump driven by the engine PTO (PTER-DIN) so an adapter is required to drive any other equipment.
- PSP-VAR** Power steering pump with variable displacement
- EBS-MED** EBS medium package including "hill" hold function
- FBREG-E** Front regulating brake valve, EBS
- SUSPL-EC** Remote electronic control on wander-lead for air suspension levelling
- FRAME300** Frame rail section external height 300 mm
- FST8080** Frame thickness - web and flange 8.0mm
- FIL-EEEB** Inner liner from end of engine to end of bogie
- FIL-EEEF** Inner liner from end of engine to end of frame
- FIL-TXEB** Inner liner from gearbox member to end of bogie
- FIL-TXEF** Inner liner from gearbox member to end of frame
- BBOX-L** Battery box located on left hand side
- BATS-D** Dual energy battery system - 2 living batteries and 2 starter batteries.
- BATS-S** Single energy battery system (2 batteries)
- 2BAT210B** 2 x 210 Ah capacity Gel batteries
- 2BATT225** 2 x 225 Ah capacity batteries
- BATTAMP** Battery voltage and ampere gauge
- BATTIND** Battery charge indication
- ADR2** ADR package for transportation of dangerous goods on road (Note does NOT include safe loading pass package if required this is quoted separately)
- MSWI-A** Main switch - ADR switch circuit shut down
- MSWI-C** Main switch - Chassis mounted toggle switch by battery box
- MSWI-R** Main switch - Key fob operated remote controlled
- R330A71** Right aluminium 710 mm D-shaped fuel tank, 330 litres volume
Min volume 210l
Max volume 810l
- UL-FUEL** Without left fuel tank
Min volume 160l
Max volume 730l
- ADTP-L** AdBlue tank on left hand side
- ADTP-R** AdBlue tank on right hand side
- ADB048** AdBlue tank usable volume 48 litres
- ADB064** AdBlue tank usable volume 64 litres
- ADB068** AdBlue tank usable volume 68 litres
- ADB090** AdBlue tank usable volume 90 litres
- ADB100** AdBlue tank usable volume 100 litres
- ADTC-BF** AdBlue tank cover with satin alloy look decorative cover
- FCAP-L** Locking fuel filler cap
- FUFF-AS** Fuel filling anti-spillage device
- FUFF-ATS** Fuel filling anti-theft and anti-spillage devices
- ESH-LEFT** Horizontal silencer, left exhaust outlet
- ESH-REAR** Horizontal silencer, rear exhaust outlet
- ESH-RIGH** Horizontal silencer, right exhaust outlet
- ESH-VERT** Horizontal silencer, vertical exhaust outlet
- EXST-SSP** Stainless steel exhaust stack - NOT polished
- EXST-ST** Steel exhaust stack
- HS-NAR** Narrow heat shield
- WHC-FIX2** Two fixed wheel chocks
- WHC-FOL2** Two foldable wheel chocks
- WHCP-F** Wheel chock(s) stored in the front part of the vehicle
- WHCP-M** Wheel chock(s) stored in the middle part of the vehicle
- WHCP-R** Wheel chock(s) stored in the rear part of the vehicle
- WHCP-T** Transport mounted wheel chock(s) stored in cab outer luggage locker
- TB-R80** Toolbox 800 mm, right side
- SUP-BAS** EC approved chassis side guards
- CHAIN-S** Snow chains
- HOOK-SC** Snow chain hooks
- TOWF-NO1** One front towing device
- TOWF-NO2** Two front towing devices
- TOWMBRH** Towing member, high mounted in centre of frame, D = 190
- TOWMBRL1** Towing member, low mounted under the frame
- TOWMBRM** Towing member, medium mounted in line with frame lower flange
- RFEC-S** Rear frame end, straight cut for regular platform applications
- RFEC-U** Rear frame end, upper cut for tipper applications.
- C-RI4040** Towing coupling, Ringfeder 4040 G-150
- C-RI5055** Towing coupling, Ringfeder 5055 G-150
- C-RO400G** Towing coupling, Rockinger 400 G-150 for 40mm eyes
- C-RO50** Rockinger RO 50 50mm for centre axle trailer
- TOWR-ONE** Towing hitch attached to rear crossmember
- TREL-PK** Trailer electrical preparation kit - chassis/cab wiring
- TREL14** Single 14 pole electrical trailer connector
- TREL15** Single 15 pole electrical trailer connector - ADR certified
- TREL7** 7 pole - 24N trailer electrical suzie
- TREL7-7** 24N and 24S trailer electrical suzies
- TBC-DUO** Duomatic type air line connectors
- TBC-EC** Palm coupling type air line connectors
- TRBR-HCF** Full pressure hand controlled trailer brake
- TRBR-STA** Stationary trailer brake control
- TRB-STRE** Stretch Brake - Automatic low speed trailer brake activation to avoid jack-knifing and improve steerability
- RUP-FOSL** Folding & sliding EC approved aluminium rear underrun
- RFEND-B** Three piece EC approved rear mud wings and spray flaps
- RFEND-T** Rear mud wings, transport mounted
- RFH-BAS** Basic rear wing height
- RFH-HIG** High rear wing height - higher wing tops
- RFH-LOW** Lower rear wing height - shallower wing tops
- ATANK-AL** Aluminium air tanks
- ATANK-ST** Steel air tanks
- TL-LED** Rear lights LED
- BLIGHT-E** Emergency brake light

WHEELS & TYRES

- RT-AL** Alcoa brushed aluminium rims with standard holes for long stud fixing on all axles
- RT-ALDP** Alcoa Dura-Bright EVO aluminium rims with standard holes long stud fixing on all axles, requires cleaning with a ph neutral solution - washing up liquid.
- RT-ALDPD** Alcoa Dura-Bright EVO aluminium rims with countersunk holes for short stud fixing on all axles, requires cleaning with a ph neutral solution - washing up liquid.
- RT-ALDU** Alcoa brushed aluminium rims with countersunk holes for short stud fixing on all axles
- RT-STEEL** Steel rims on all axles
- WCAP** Aerodynamic hub caps
- SPWT-D** Spare wheel & tyre with rear tyre pattern
- SPWT-F** Spare wheel & tyre with front tyre pattern
- SWCP-LF** Spare wheel carrier on left side of chassis ahead of rear axle
- SWCP-R** Rear mounted spare wheel carrier
- SWCP-T** Spare wheel supplied temporarily strapped to chassis
- SWCP-TP** Temporary spare wheel carrier on top of chassis frame
- JACK-12T** 12 tonne bottle jack
- JACK-15T** 15 tonne bottle jack
- JACK-20T** 20 tonne bottle jack
- TOOL-BAS** Basic Toolkit
- TOOLKIT** Complete tool kit

Standard Equipment Optional Equipment

For more detailed information about cab and powertrain equipment, please refer to separate specification sheets.

For all possible options and combinations of options please consult your Volvo sales contact who can create a specification to match your requirements using the Volvo Sales Support system (VSS).

The factory reserves the right to modify design and change equipment without previous notification. The specification can vary from country to country.

MODEL RANGE

FH 16 8x2 Rigid - Pusher Axle Tridem – contact sales engineering reference application

- INFLAHOS** Tyre inflation hose
- GAUGE-TP** Tyre pressure gauge
- DRIVELINE EQUIPMENT**
- ASO-C** Crawler gear -
Ratio direct top gearbox 19:1
Ratio Overdrive gearbox 17:1
- ASO-ULC** Ultra low crawler and crawler gear -
Ratios direct top gearbox 32:1 and 19:1
Ratios Overdrive box 32:1 and 17:1
- **TRAP-HD** Reinforced gearbox application
- TP-CON** Construction Package
- TP-DIST** Distribution Package
- TP-HD** I-shift software - Heavy duty for high GCW
Special conditions apply consult Sales Engineering
- TP-LONG** Long Haul Package
- AMSO-AUT** Enhanced I-shift software with manual shift available in auto mode and kickdown facility on accelerator pedal
- AVO-ENH** Enhanced software for off road driveability and starting
- APF-ENH** I-shift enhanced PTO functions
- CD43-O** Dual plate clutch, plate diameter 430 mm
- RET-TH** Gearbox mounted retarder
- TC-MAOH2** Extra high performance transmission oil cooler - air to oil with front mounted radiator
- TC-MWO** Basic transmission oil cooler - water to oil
- 2COM1100** Two cylinder, air compressor, 1100 litres per minute
- **2COMP900** Two cylinder, air compressor, 900 litres per minute
- CLU-AIRC** Clutchable air compressor
- AIRIN-FR** Front air intake fitted to the underside of cab engine tunnel
- **AIRIN-HI** Roof mounted air intake behind cab on left hand side
- AIRIN-LO** Low level air intake behind cab on left hand side
- ACL1ST-S** Two stage air filter
- **24AL120B** 120 amp alternator
- 24AL150B** 150 amp alternator
- **CCV-C** Closed crankcase engine ventilation
- CCV-OX** Closed crankcase ventilation for cold markets
- **PRIM-EL** Electrical priming pump
- AF-R** Hot fuel recirculation heated fuel filter
- FUEFE2LW** Large engine mounted dual fuel filter with water separator
- **FUEFE2SW** Small engine mounted dual fuel filter with water separator
- EST-AID** Air inlet manifold starting heater element
- 220EBH15** 220V/1.5Kw electric engine block heater
- PTER-100** Rear engine mounted power-take-off with DIN 100 / ISO 7646 flange
- PTER-DIN** Rear engine mounted PTO with DIN5462 (female) splined shaft for a close coupled pump.
Models with 3 steering axles will use this to drive the steering pump (AUXPSP)
- PTER1400** Rear engine mounted power-take-off with SAE 1410 flange
- HPE-F101** Parker F1-101, engine mounted, fixed displacement, single flow, engine mounted hydraulic pump
- HPE-F41** Parker F1-41, engine mounted, fixed displacement, single flow, engine mounted hydraulic pump
- HPE-F51** Parker F1-51, engine mounted, fixed displacement, single flow, engine mounted hydraulic pump
- HPE-F61** Parker F1-61, engine mounted, fixed displacement, single flow, engine mounted hydraulic pump
- HPE-F81** Parker F1-81, engine mounted, fixed displacement, single flow, engine mounted hydraulic pump
- HPE-T53** Parker F2-53/53, engine mounted, Fixed displacement, Twin flow engine mounted hydraulic pump
- HPE-T70** Parker F2-70/35, engine mounted, Fixed displacement, Twin flow engine mounted hydraulic pump
- HPE-V45** Parker VP1-45, variable displacement, single flow, engine mounted hydraulic pump
- HPE-V75** Parker VP1-75, variable displacement, single flow, engine mounted hydraulic pump
- PTR-D** Gearbox PTO for plug-in pump, 0.71xeng speed
- PTR-DH** Gearbox driven high speed PTO for one plug-in hydraulic pump
- PTR-DM** Gearbox driven medium speed PTO for one plug-in hydraulic pump
- PTR-F** Gearbox driven PTO with rear flange connection
- PTR-FH** Gearbox driven high speed PTO with SAE drive flange
- PTR-FL** Gearbox driven low speed PTO with SAE drive flange
- PTRD-D** Gearbox driven HIGH SPEED PTO for two plug-in hydraulic pumps
- PTRD-D1** PTRD-D1 Gearbox driven HIGH SPEED PTO (1 SAE flange & 1 plug-in hydraulic pump)
- PTRD-D2** Gearbox driven HIGH SPEED PTO (2 SAE flanges & 1 plug-in hyd pump)
- PTRD-F** PTO with 1 DIN + 1 flange connection rear, manual gearbox
- HPG-F101** Parker F1-101 gearbox mounted, fixed displacement, single flow, hydraulic pump
- HPG-F41** Parker F1-41 gearbox mounted, fixed displacement, single flow, hydraulic pump
- HPG-F51** Parker F1-51 gearbox mounted, fixed displacement, single flow, hydraulic pump
- HPG-F61** Parker F1-61 gearbox mounted, fixed displacement, single flow, hydraulic pump
- HPG-F81** Parker F1-81 gearbox mounted, fixed displacement, single flow, hydraulic pump
- EIDLESD** Engine idle shut down
- DTRI-PER** Dashboard in darker peregrine greyish brown. Steering wheel grey and door panels in light beige for FH and black for FH16. Dashboard and steering wheel cover in light beige skylark. Door panels in light beige for FH and black for FH16.
- DTRI-SRA** Dashboard and steering wheel cover in light beige skylark. Door panels in light beige for FH and black for FH16.
- **STWPOS-R** RIGHT HAND DRIVE
- **STWM-LE** Leather steering wheel
- STGW-AD2** Adjustable steering wheel with neck tilt
- **STGW-ADJ** Adjustable steering wheel
- **AIRBAG** SRS Driver's air bag
- **DRC-AMII** DPF Regeneration control switch - for manual and switching off regeneration
- **1DAYDIG2** Continental VDO DTCO 4.0 smart tachograph
This tachograph can ONLY offer remote download if the option of Dynafleet or an FMS gateway has been specified with this order.
- 1DAYDIGP** Continental VDO DTCO 3.0 digital tachograph
For vehicles with long lead time - this includes prep kit for the retrofit of DTCO 4.0 tachograph.
For updating to new legal demand for trick registration from 15th June 2019.
This tachograph can ONLY offer remote download if the option of Dynafleet or an FMS gateway has been specified with this order.
- ARSL** Additional road speed limit - switch in dashboard
- CRUISE-E** Eco cruise control (with eco-roll and I-cruise, controls in steering wheel)
- **CRUISEC** Cruise control, standard
- HWSS-AC** Adaptive cruise control with forward collision warning
- LSS-DW** Lane departure-warning system
- LCS** Lane change support
- DAS-W** Driver Alert Support system
- RSENS-W** Rain sensing windscreen wipers

■ Standard Equipment

Optional Equipment

For more detailed information about cab and powertrain equipment, please refer to separate specification sheets.

For all possible options and combinations of options please consult your Volvo sales contact who can create a specification to match your requirements using the Volvo Sales Support system (VSS).

The factory reserves the right to modify design and change equipment without previous notification. The specification can vary from country to country.

MODEL RANGE

FH 16 8x2 Rigid - Pusher Axle Tridem – contact sales engineering reference application

| | | | |
|-------------------|--|-------------------|--|
| ■ CU-ECC | Electrically controlled air conditioning with sun sensor | □ DST-LUX2 | Deluxe suspended drivers seat features: electrical adjustment with memory function, seatbelt in seat and heated cushions |
| □ CU-ECC2 | Electrically controlled air conditioning with sun sensor, mist sensor, air quality sensor and carbon filter | □ SBD-RED | Red seat belts |
| ■ IMMOBIL | Thatcham H2 approved immobiliser | □ SBPRE-DS | Driver seat belt pretensioner |
| □ ALARM-B | Thatcham H1 approved vehicle alarm - Cab only | □ PST-BAS1 | Passenger seat - Fixed non suspended fold up with seatbelt mounted in cab |
| □ ALARM-E | Enhanced vehicle alarm - Thatcham H1 approved - Cab plus external sensor for body/trailer | □ PST-BSL1 | Passenger seat - Sliding non suspended fold up with seatbelt mounted in cab |
| □ ALCOLOCK | Alcolock | □ PST-CF4 | Passenger seat - Comfort suspended with seatbelt mounted in seat |
| □ AMPL400 | Radio amplifier, 8 channel, 400 W with subwoofer Located in right hand external storage box | □ PST-CF5 | Passenger seat - Comfort suspended & heated with seatbelt mounted in seat |
| □ BUPMON | Back up monitor with built in 7" screen on dash and one colour camera supplied loose for fitment by bodybuilder. Can accommodate up to 4 cameras for TfL Safe Scheme, CLOCS and FORS. | □ PST-RX1 | Passenger seat - Fixed non suspended, features: 90 degree rotation and tilt function with seatbelt mounted in cab |
| □ PHONE-PK | Telephone preparation kit (antenna, antenna attachm. cable incl.) | □ PST-RX2 | Passenger seat - Fixed non suspended, features: 90 degree rotation, tilt and heated functions with seatbelt mounted in cab |
| ■ WLIFT-AD | Electrical window lift, automatic up/down driver side | □ PST-STD2 | Passenger seat - Fixed non suspended with seatbelt mounted in cab |
| □ ISUNS-BS | Side interior sun visor on both sides | ■ PST-STD4 | Passenger seat - Standard suspended with seatbelt mounted in cab |
| ■ ISUNS-DS | Driver's side interior sun visor | □ SBPRE-PS | Passenger seat belt pretensioner |
| □ ISUNF-RE | Electrically operated textile interior sun blind | ■ ARMRE-BB | Two armrests on both driver and passenger seat. |
| ■ ISUNF-RM | Manually operated textile interior sun blind | ■ ARU-LEA | Leather upholstered armrest |
| ■ CSPL-BX | Lower center dash open storage box | ■ GRABHI-L | Leather covered instep cab grab handle |
| □ CSPL-BXD | Lower centre dash drawer | □ FMAT-RUB | Rubber floor mats |
| □ CSPU-SDR | One open storage and one drawer - behind push open lid - in upper part of the centre dash panel | ■ FMAT-TX2 | Textile and rubber floor mats |
| ■ CSPU-SS | Two open storages - behind push open lid in upper part of the centre dash panel | ■ LBK80F | Lower fixed bunk with wide middle section 815 in the centre x 2000 mm |
| □ ADFS | Two extra DIN slots in front shelf - can be fitted with card or drawer available as an accessory | □ LBK80FRE | Lower electrically operated recline bunk with wide middle section 815 in the centre x 2000 mm |
| ■ BUPALARM | Reverse alarm | □ LBK80FRM | Lower manually operated recline bunk with wide middle section 815 in the centre x 2000 mm |
| □ RTOLL-PK | Road toll PREPARATION kit for trucks operating with "Toll Collect" in Germany | □ MATL-FI | Firm lower bunk pocket sprung mattress |
| □ LOADIND | Load indicator with central dashboard display | ■ MATL-SF | Lower flexizone mattress - semi-firm, pocket springs up to 100kg - 16 stone |
| □ REMC-MF | Multi-functio wireless remote control | □ MATL-SO | Lower flexizone mattress - soft, pocket springs up to 85kg - 13.5 stone |
| □ FIREXT3S | 3kg fire extinguisher mounted on seat base | □ OLMAT-BA | 35mm mattress overlay protector |
| □ WARNVEST | High visibility warning vest - no sleeves | ■ OLMAT-PR | 50mm premium mattress overlay protector |
| □ AIDKIT | First aid kit | □ TBK60AD | Height adjustable foldable top bunk 600 x 1900mm |
| □ AIDKIT1B | First aid kit | □ TBK60F | Fixed foldable top bunk 600 x 1900mm |
| □ WARNLAMP | Portable warning lamp | □ TBK70AD | Height adjustable foldable top bunk 700 x 1900mm |
| □ LAMP-IN | Inspection lamp | □ TBK70F | Fixed foldable top bunk 700 x 1900mm |
| □ BULBKIT | Bulb and fuse kit | □ PH-CAB2 | 1.8kW Air to air night heater |
| ■ WRITEPAD | Writing pad | □ PH-ENGCA | Engine and cab night heater |
| □ UPHTRIO4 | Interior trim: Seats: Black/green textile insert, black leather bolster & green/yellow leather side insert Cab walls: Soft textile with matching grey, green and black colours | ■ SLCP-BAS | Basic sleeper control panel - includes interior light, parking heater, roof hatch and door lock |
| □ UPHTRIO5 | Interior trim: Seats: Light grey leather insert and black leather bolster Cab walls: In matching grey vinyl | □ SLCP-LUX | Luxury sleeper control panel - includes interior light, parking heater, roof hatch, door lock, alarm clock, window and radio |
| □ UPHTRIO8 | Interior trim: Seats: Black with green perforated leather insert and yellow side edging Cab walls: soft textiles in matching grey, green and black | □ SAFE | Safe box for driver's personal items |
| ■ DST-CF4 | Driver seat, comfort, suspended, belt in seat | □ RUS-BAS | Rear cab upper storage 154 litres - 300 mm high |
| □ DST-CF5 | Driver seat, comfort, suspended, belt in seat, electrically heated | □ RUS-HIG | Rear cab upper storage 245 litres - 440 mm high |
| □ DST-CF6 | Driver seat, comfort, suspended, belt in seat, electrically heated, ventilated | □ TABLE | Folding and height adjustable table - on lower bunk |
| □ DST-LUX1 | Deluxe suspended drivers seat features: electrical adjustment with memory function, seatbelt in seat with heated & ventilated | □ REFR-RUS | Fridge: 28 litre rear upper wall mounted with dividers |
| | | □ REFRIG | Fridge: 33 litre under bunk mounted with freezer dividers |
| | | □ MICRO-PK | Preparation kit for microwave oven (wiring) |
| | | □ BOTH-D | One bottle holder under dashboard centre section |
| | | □ BOTH-DL | Two bottle holders, one under dashboard centre section and one mounted to the under bunk drawer |
| | | □ BOTH-L | One bottle holder mounted to the under bunk drawer |
| | | □ COFMA-PK | Coffee maker, preparation kit. |
| | | □ INLI-BAS | Interior white LED lights - basic |

■ Standard Equipment

□ Optional Equipment

For more detailed information about cab and powertrain equipment, please refer to separate specification sheets.

For all possible options and combinations of options please consult your Volvo sales contact who can create a specification to match your requirements using the Volvo Sales Support system (VSS).

The factory reserves the right to modify design and change equipment without previous notification. The specification can vary from country to country.

MODEL RANGE

FH 16 8x2 Rigid - Pusher Axle Tridem – contact sales engineering reference application

- | | |
|---|---|
| <ul style="list-style-type: none"> <input type="checkbox"/> INLI-NL Interior white and red night LED light with no dimmer <input checked="" type="checkbox"/> INLI-NLD Interior white and red night LED light with dimmer <input type="checkbox"/> ARL-FLEX Two flexible reading lamps (snake lamps) <input checked="" type="checkbox"/> RH-EE Without roof hatch -Tinted glass emergency exit ONLY <input type="checkbox"/> RH-ETR Glass roof & escape hatch - Electrically operated, tinted glass with rear opening <input type="checkbox"/> RH-MTR Glass roof & escape hatch - Manually operated, tinted glass with rear opening <input type="checkbox"/> URH Without roof hatch <input type="checkbox"/> SWIND-BS Extra side window on both sides behind "B" pillar <input checked="" type="checkbox"/> VANMIR Vanity mirror in front shelf <input type="checkbox"/> AS-FUS Extra shelf in front upper storage compartments <input type="checkbox"/> INFOT-PK Preparation kit for the mounting of a flat screen TV in cab above the driver's door, includes bracket, electrical and speaker connections | <ul style="list-style-type: none"> <input type="checkbox"/> CL-STAT Static corner lights <input type="checkbox"/> ASL-RF2 Two Hella H11 70W spotlamps in sign box - only available with the basic headlight and no lower driving lights. <input type="checkbox"/> BEACO2F Two front roof mounted amber beacon rotating warning lamps <input type="checkbox"/> BEACO2R Two rear roof mounted (on accessory bracket) amber beacon flashing warning LED lamps <input type="checkbox"/> BEACON-P Roof beacon wire preparation <input type="checkbox"/> BEACONA4 Four roof mounted (2 front/2 rear) amber beacon rotating warning lamps <input type="checkbox"/> CABPT-R1 Single outlet for roof mounted accessories <input checked="" type="checkbox"/> CABPT-R2 Twin outlets for roof mounted accessories. <input type="checkbox"/> SPOTP-F Spotlamp preparation in front, max 280W <input type="checkbox"/> SPOTP-R Spotlamp preparation on roof, max 280W <input type="checkbox"/> SPOTP-RF Spotlamp preparation on cab roof and in cab front, max 2x280W <input type="checkbox"/> ROS-IL2 Preparation kit for illuminated roof sign with switch loose in cab, fit after registration <input type="checkbox"/> CSGN-ENG Engine size and power headboard logo <input type="checkbox"/> CSGN-GTR "Globetrotter" headboard logo <input checked="" type="checkbox"/> HORN-F1S Single tone Jericho air horn chassis mounted <input type="checkbox"/> HORN-R2S Two roof mounted air horns <input type="checkbox"/> ANT-CBR Roof mounted antenna for CB radio, single aerial <input type="checkbox"/> ACCBR-AP Front, middle & rear roof mounted accessory brackets <input type="checkbox"/> ACCBR-F Front roof mounted accessory bracket <input type="checkbox"/> ACCBR-FM Front & middle roof mounted accessory brackets <input type="checkbox"/> ACCBR-FR Front & rear roof mounted accessory brackets <input type="checkbox"/> ACCBR-M Middle roof mounted accessory bracket <input type="checkbox"/> ACCBR-R Rear roof mounted accessory bracket <input type="checkbox"/> ACCBR-RM Rear & middle roof mounted accessory brackets <input type="checkbox"/> STUC-B Left and right storage compartments under cab <input type="checkbox"/> STUC-L Left storage compartment under cab <input type="checkbox"/> STUC-R Right storage compartment under cab <input type="checkbox"/> REFS-TW White cab conspicuity markings by packed in cab <input type="checkbox"/> REFS-TY Yellow cab conspicuity markings by packed in cab |
|---|---|
- CAB EXTERIOR**
- | | |
|--|---|
| <ul style="list-style-type: none"> <input type="checkbox"/> EXTL-BAS Basic exterior finish - Matt Volvo badges, grey instep, bumper, bumper spoiler, mirror housing and sun visor <input checked="" type="checkbox"/> EXTL-ENH Enhanced exterior finish - Chrome style Volvo badges, painted instep, bumper, bumper spoiler if specified, mirror housing and sun visor <input checked="" type="checkbox"/> GLAS-TIN Tinted windows. <input checked="" type="checkbox"/> DGLAS-H Tempered door glass <input type="checkbox"/> DGLAS-L Laminated door glass <input checked="" type="checkbox"/> LOCK-REM Central locking with remote control <input type="checkbox"/> BUMP-B Plastic front bumper <input checked="" type="checkbox"/> BUMP-B2 Steel front bumper <input type="checkbox"/> BUMP-HD Heavy duty front bumper <input type="checkbox"/> BUMP-SP Front bumper spoiler <input type="checkbox"/> GUARD-EH Engine guard to protect sump and engine hoses <input checked="" type="checkbox"/> BUGNET Insect screen in front of radiator <input type="checkbox"/> CTILT-P-E Electrically operated hydraulic cab tilt <input checked="" type="checkbox"/> CTILT-P-M Manually operated hydraulic cab tilt <input type="checkbox"/> FCABS-A Front cab suspension - Air <input checked="" type="checkbox"/> FCABS-M Front cab suspension - Mechanical spring <input type="checkbox"/> RCABS-A Rear cab suspension - Air <input checked="" type="checkbox"/> RCABS-M Rear cab suspension - Mechanical spring <input checked="" type="checkbox"/> HCC-INEX Exterior and interior hood catch control <input type="checkbox"/> MIRCOMF Electrically heated and operated main and wide angle mirrors and manually adjusted kerb view mirror on passenger side <input checked="" type="checkbox"/> MIRSTD Electrically heated main and wide angle mirrors and manually adjusted kerb view mirror on passenger side <input checked="" type="checkbox"/> AMIR-F20 Auxiliary front view mirror with a 200mm radius <input type="checkbox"/> SUNV-H External smoke grey sunvisor <input type="checkbox"/> AD-ROOF Roof air deflector <input type="checkbox"/> AD-SIDES Short cab side air deflector for rigid bodywork <input checked="" type="checkbox"/> HL-BASIC Halogen H7 head lamps <input type="checkbox"/> HL-BHID High intensity Bi-Xenon head lamps <input type="checkbox"/> HL-DBL Bi-Xenon high intensity discharge and dynamic head lamps. Dipped beam follows the road, activated by a signal from the steering system. <input type="checkbox"/> HL-CLEAN Head lamp cleaner - washer jets <input type="checkbox"/> HLP-ST Headlamp protection <input type="checkbox"/> HL-ADJ Headlight adjustment - Switch in cab <input type="checkbox"/> DRIVL2 Two spot lamps <input type="checkbox"/> UDRIVL Without auxiliary driving lights <input checked="" type="checkbox"/> FOGL-WC Front fog lights | <p>SUPERSTRUCTURE PREPARATIONS</p> <ul style="list-style-type: none"> <input type="checkbox"/> SRWL-PK Wiring preparation for side & rear work/reverse lamps on side of chassis and a three-position switch, maximum 280W <input type="checkbox"/> SWL-2FW Two H3 70W white front chassis mounted (LH/RH side) working lamps and a 2-position switch (On/Off) <input type="checkbox"/> SWL-2RW Two H3 70W white rear chassis mounted (LH/RH side) working lamps and a 2-position switch (On/Off) <input type="checkbox"/> SWL-4W 4 H3 70W white front (2) & rear (2) chassis mtd (LH/RH side) working lamps & 2-pos switch (On/Off) <input type="checkbox"/> SWL-PK Wiring preparation for side work/reverse lamps on side of chassis and a three-position switch, maximum 280W <input type="checkbox"/> WLC-H2W Two H3/70W white working lamps high mounted on the back of cab <input type="checkbox"/> WLC-PKCH Preparation kit (cables and switch) for cab mounted chassis working lamp <input type="checkbox"/> WLC-PKH Preparation kit, cables and switch for high mounted working lamps back of cab <input type="checkbox"/> WLC-PKL Preparation kit, cables and switch for low mounted working lamps back of cab <input type="checkbox"/> WLC-PKLH Preparation kit - cables and switch for low and high mounted working lamps back of cab. <input checked="" type="checkbox"/> ECBB-BAS Body builder electrical centre without body builder module <input type="checkbox"/> ECBB-HIG Body builder electrical centre with body builder module <input type="checkbox"/> BBCHAS1 One 7-pole connector for Body builder interface <input type="checkbox"/> BBCHAS3 Three 7-pole connectors for Body builder interface <input type="checkbox"/> BEPR-T2 Body builder electrical software preparation for tipper with remote control <input type="checkbox"/> EXSTER External steering control, with VDS and bodybuilder module <input checked="" type="checkbox"/> TD-LED Trailer detection with LED sensing |
|--|---|

Standard Equipment Optional Equipment

For more detailed information about cab and powertrain equipment, please refer to separate specification sheets.

For all possible options and combinations of options please consult your Volvo sales contact who can create a specification to match your requirements using the Volvo Sales Support system (VSS).

The factory reserves the right to modify design and change equipment without previous notification. The specification can vary from country to country.

MODEL RANGE

FH 16 8x2 Rigid - Pusher Axle Tridem – contact sales engineering reference application

- **FRFS-BS** Frame rail free space on both sides to give space for crane legs or other equipment.
- **FBA-BTF** Lower front body attachments for torsionally flexible - platform body
- **FBA-BTSF** Lower front body attachments for torsionally semi-flexible body - box or curtainsider
- **HBA-FSFB** Holes for body attachments - flexible/semi-flexible body
- **HBA-SB** Holes for body attachments - stiff body
- **RBA-T2** Lower rear body attachments for helper frame
- **CRANEPK1** Crane plates mounted to frame, for cranes up to 10 tonne metre capacity
- **CRANEPK2** Crane plates mounted to frame, for cranes up to 20 tonne metre capacity
- **CRANEPK4** Crane plates mounted to frame, for cranes up to 40 tonne metre capacity
- **AUXL-SPK** Electrical preparation kit - wiring and switch for snow plough lights
- **TAILPRE2** Tail lift preparation kit, wireless remote operation
- **TAILPREP** Taillift preparation kit - cab switch and warning in driver display
- **AESW2** Two Body builder bistable electrical switches (marked AUX1 / AUX2)
- **AESW2PK** 2 Body builder bistable el.switches (marked AUX1/AUX2) and prep. for 4 more switches
- **AUXSW-4** Wiring for 4 extra switches (from Body builder electrical centre to switch positions)

DELIVERY SERVICES

- **TGW-4GWL** GSM/GPRS/4G modem, LTE & WLAN for telematics gateway
- **FMS-PK** Fleet Management System gateway

VOLVO

Volvo Truck Corporation
volvotrucks.com