

# MODEL RANGE

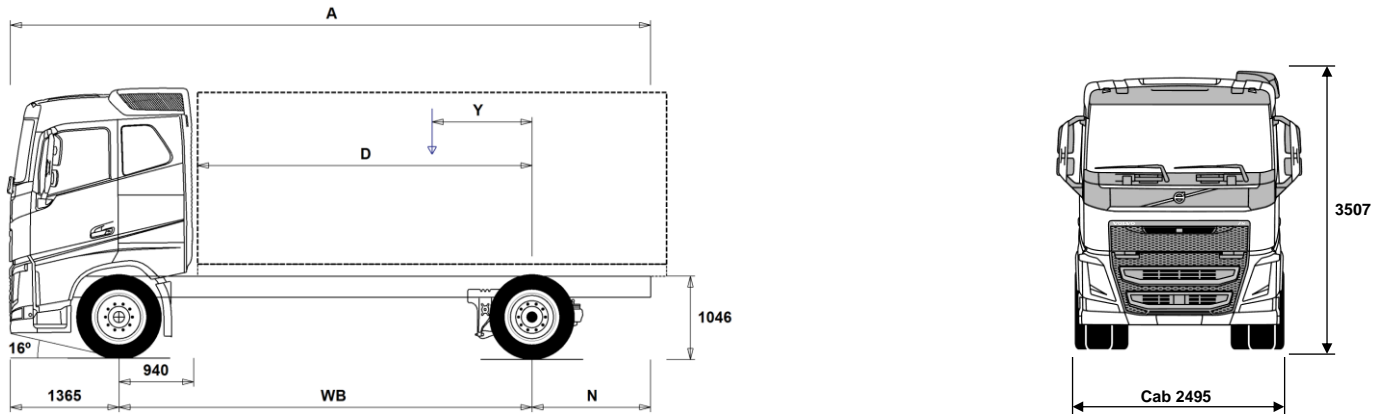

Volvo Trucks. Driving Progress

FH LNG 4x2 Rigid - Rear Air Suspension - Contact Regional Business Manager before



## Chassis Dimensions [mm]

|  |             |
|--|-------------|
| <b>WB Wheelbase</b>                    | <b>5200</b> |
| A Overall Chassis Length               | 9660        |
| D Center of rear axle to front of body | 4210        |
| N Rear Overhang (Min.)                 | 1395        |
| N Rear Overhang (Max.)                 | 3095        |
| Y Center of Gravity for Payload (Min.) | 708         |
| Y Center of Gravity for Payload (Max.) | 1436        |

## Chassis Weights [kg]

|  |       |
|--|-------|
| Front Axle                                   | 5040  |
| Rear Axle                                    | 2245  |
| Kerb Weight                                  | 7285  |
| Payload (including body, driver, fuel, etc.) | 10715 |

## Turning Diameter [mm]

|                                      |       |
|--------------------------------------|-------|
| Turning Circle Diameter Kerb to Kerb | 18800 |
| Turning Circle Diameter Wall to Wall | 20100 |

## Plated Weights [kg]

|                          | Plated | Design |
|--------------------------|--------|--------|
| Gross Vehicle Weight     | 18000  | 21000  |
| Gross Combination Weight | 40000  | 44000  |
| Front Axle               | 8000   | 8000   |
| Rear Axle                | 11500  | 13000  |

## Important Notes

### Chassis Dimensions

Cab Height: +305 mm for CAB-HSLP, -283 mm for CAB-LSLP, +450 mm for CAB-XHSL.

D-measure includes a front clearance of 50 mm and for rigid trucks also a subframe of 100 mm.

Height can vary  $\pm 20$  mm for leaf and  $\pm 10$  mm for air suspension.

All dimensions are for unladen chassis and any tag axles down. Chassis height used: CHH-HIGH.

Rear overhang used for vehicle weight calculation is the maximum rear overhang (N Max.) for selected wheelbase.

Height change when chassis height CHH-MED,FRAME266: 0 mm.

Weight and dimensions are based upon the following tyres:

|                   |             |
|-------------------|-------------|
| Front Axle Tyres: | 315/80R22.5 |
| Drive Axle Tyres: | 315/80R22.5 |

**Chassis weight includes oil, water, AdBlue, 0 litres fuel and without driver. Kerb weight can vary  $\pm 3\%$ .**

Turning diameters are theoretically calculated.

Legal weights can differ from country to country.

For more detailed weight information, including optional equipment weights, ask your Volvo sales contact to enter your specification into the Volvo Weight Information system (WIS).

Do NOT use this drawing for bodybuilding. Refer to Volvo Bodybuilder Instructions and chassis assembly drawing FH42RLA.

# MODEL RANGE

## FH LNG 4x2 Rigid - Rear Air Suspension - Contact Regional Business Manager before

### CORE COMPONENTS

- CHH-HIGH** Chassis height high - N3 "On Road" chassis - For a specific loading height always check the unique BEP chassis drawing
- CHH-MED** Chassis height medium - For a specific loading height always check the unique BEP chassis drawing
- FH-HSLP** Globetrotter cab - all steel safety cage design with roof mounted emergency escape hatch. Designed and built to Swedish impact and ECE R29 regulations
- FH-SLP** Sleeper cab - all steel safety cage design with roof mounted emergency escape hatch. Designed and built to Swedish impact and ECE R29 regulations
- FH-XHSL** Globetrotter XL cab - all steel safety cage design with roof mounted emergency escape hatch. Designed and built to Swedish impact and ECE R29 regulations
- EU6SCR** Emission level - Euro 6
- G13C420** G13C420 Liquid Natural Gas engine developing 420hp at 1400-1800rpm. Peak torque 2100Nm at 1000 -1400rpm.
- G13C460** G13C460 Liquid Natural Gas engine developing 460hp at 1700-1800rpm. Peak torque 2300Nm at 1100 -1300rpm.
- EBR-EPGC** Exhaust pressure governor for I shift gearbox
- EBR-VEB+** Volvo engine brake + and exhaust pressure governor, enhanced performance from additional exhaust rocker control. Retardation 375kW
- AT2612F** AT2612F 12-speed "I-shift" automated mechanical gearbox suitable for gross train weights up to 60tonne only refer to sales engineering when used in conjunction with a PTO
- ATO2612F** ATO2612F 12-speed "I-shift" overdrive automated mechanical gearbox suitable for gross train weights up to 60tonne refer to sales engineering when used in conjunction with a PTO
- RSH1370F** RSH1370F hub reduction rear axle with differential lock - design GCW 70 tonne
- RSS1344E** RSS1344E single reduction rear axle with differential lock - design GCW 44tonne
- RSS1352A** RSS1352A single reduction 13 tonne rear axle with differential lock - design GCW 52 tonne
- RSS1356** RSS1356 single reduction rear axle with differential lock - design GCW 56 tonne
- RSS1370A** RSS1370A single reduction 13 tonne rear axle with differential lock - design GCW 70 tonne
- RSS1370B** RSS1370B single reduction 13 tonne rear axle with differential lock - design GCW 70 tonne

### PACKAGES

- DRIVE** Cab Package: Drive
- DRIVE+** Cab Package: Drive +
- DRIVE++** Cab Package: Drive ++
- DRIVE5** Cab Package: Drive
- DRIVE5+** Cab Package: Drive +
- DRIVE5++** Cab Package: Drive ++
- 1BED** Living package with single bed:
- 1BED+** Living package with single bed plus:
- 1LIVIN++** Sleeper Package: Living ++ package with single bunk
- 1LIVING** Sleeper Package: Living package with single bunk
- 1LIVING+** Sleeper Package: Living + package with single bunk
- 2BED** Living package with two beds:
- 2BED+** Living package with two beds plus:
- 2LIVIN++** Sleeper Package: Living ++ package with two bunks
- 2LIVING** Sleeper Package: Living package with two bunks
- 2LIVING+** Sleeper Package: Living + package with two bunks
- AUDHIG** High Power Audio system: RDS radio with CD player - also playing MP3/WMA files from CD -, with integrated bluetooth phone and USB/Line inputs. FM/AM antenna, speakers in dashboard, doors, and sleeping compartment.
- MEDIA** AM/FM Bluetooth radio without CD player. USB and Aux line inputs.

- Standard Equipment
- Optional Equipment

For more detailed information about cab and powertrain equipment, please refer to separate specification sheets.

For all possible options and combinations of options please consult your Volvo sales contact who can create a specification to match your requirements using the Volvo Sales Support system (VSS).

The factory reserves the right to modify design and change equipment without previous notification. The specification can vary from country to country.

- MEDIA** Speakers in dashboard, doors, and sleeping compartment. 7" touch screen with personal apps. AM/FM Bluetooth radio without CD player. USB and Aux line inputs.
- MEDIA** Speakers in dashboard, doors, and sleeping compartment. 7" touch screen with personal and professional apps. Dynafleet vehicle on-board data display with office internet support.
- MEDIA** AM/FM Bluetooth radio without CD player. USB and Aux line inputs.
- MEDIA** Speakers in dashboard, doors, and sleeping compartment. 7" touch screen with personal and professional apps. Truck based satellite navigation (live updates not included) AM/FM Bluetooth radio without CD player. USB and Aux line inputs.
- MEDIA** Speakers in dashboard, doors, and sleeping compartment. 7" touch screen with personal and professional apps. Truck based satellite navigation (live updates not included) Dynafleet vehicle on-board data display with office internet support.
- VISI15** Visibility Package
- VISI15+** Visibility Plus Package
- VISI5** Visibility Package
- VISI5+** Visibility + Package
- VISI5++** Visibility ++ Package
- VISIC15** Visibility Package
- VISIC5** Visibility Package
- VISIC5+** Visibility + Package
- ASAF15** Active Safety Package
- SAFE-VE** Active Safety Package
- SAFE-VE+** Active Safety + Package

### CHASSIS

- FST-AIR** Front suspension type - air
- FST-PAR** Front suspension type - 2 leaf parabolic springs
- FSL5-BAS** Front suspension levelling - basic stroke
- FSL5-HI** Front suspension levelling - high stroke for demount operations - check with bodybuilder
- FAL7.5** Front axle design capacity 7.5 tonnes
- FAL8.0** Front axle design capacity 8.0 tonnes - Ensure that you have checked the tyre load index
- FAL8.5** Front axle design capacity 8.5 tonnes
- FAL9.0** Front axle design capacity 9.0 tonnes - Ensure that you have checked the tyre load index
- FSTAB** Front anti-roll bar
- FSTAB2** Front anti-roll bar medium stiffness
- FSTAB3** Front stiff anti-roll bar
- RAL13** Rear axle design capacity 13 tonnes
- ASF-DL1** Air suspension with 1 driving level
- ASF-DL3** Air suspension with 3 driving levels
- ACTST-TO** Volvo Dynamic Steering (VDS) with with extra electronic pump and torque overlay
- ASFE-BAS** Active steering feature - Basic - Volvo Dynamic Steering only
- ASFE-PS** Active steering feature - Volvo Dynamic Steering with personal settings
- PSP-VAR** Power steering pump with variable displacement
- EBS-MED** EBS medium package including "hill" hold function
- AUXPARK** Additional spring parking brakes
- FRAME266** Frame rail section external height 266 mm
- FRAME300** Frame rail section external height 300 mm
- FST6060** Frame thickness - web and flange 6.0mm
- FST7070** Frame thickness - web and flange 7.0mm
- FST8080** Frame thickness - web and flange 8.0mm
- FIL-EEEB** Inner liner from end of engine to end of bogie
- FIL-EEEF** Inner liner from end of engine to end of frame
- FIL-TXEB** Inner liner from gearbox member to end of bogie
- FIL-TXEF** Inner liner from gearbox member to end of frame

# MODEL RANGE

FH LNG 4x2 Rigid - Rear Air Suspension - Contact Regional Business Manager before

- **BBOX-L** Battery box located on left hand side
- **2BAT210B** 2 x 210 Ah capacity Gel batteries
- **2BATT170** 2 x 170 Ah capacity batteries
- **2BATT225** 2 x 225 Ah capacity batteries
- **BATTAMP** Battery voltage and ampere gauge
- **BATTIND** Battery charge indication
- **ADR1** ADR package for transportation of dangerous goods on road (Note does NOT include safe loading pass package if required this is quoted separately)
- **ADR2** ADR package for transportation of dangerous goods on road (Note does NOT include safe loading pass package if required this is quoted separately)
- **MSWI-A** Main switch - ADR switch circuit shut down
- **MSWI-C** Main switch - Chassis mounted toggle switch by battery box
- **MSWI-R** Main switch - Key fob operated remote controlled
- **R170A71** Right aluminium 710mm 170litre (165l usable) D-shaped fuel tank  
Min volume 170l  
Max volume 170l
- **ADTP-R** AdBlue tank on right hand side
- **ADB064** AdBlue tank usable volume 64 litres
- **FCAP-L** Locking fuel filler cap
- **FUFF-AS** Fuel filling anti-spillage device
- **FUFF-ATS** Fuel filling anti-theft and anti-spillage devices
- **LGAS205** Left mounted 205 kilogram gas tank
- **ESH-LEFT** Horizontal silencer, left exhaust outlet
- **ESH-REAR** Horizontal silencer, rear exhaust outlet
- **ESH-RIGH** Horizontal silencer, right exhaust outlet
- **HS-NAR** Narrow heat shield
- **WHC-FIX1** One fixed wheel chock
- **WHC-FIX2** Two fixed wheel chocks
- **WHC-FOL1** One foldable wheel chock
- **WHC-FOL2** Two foldable wheel chocks
- **WHCP-F** Wheel chock(s) stored in the front part of the vehicle
- **WHCP-R** Wheel chock(s) stored in the rear part of the vehicle
- **WHCP-T** Transport mounted wheel chock(s) stored in cab outer luggage locker
- **TB-R80** Toolbox 800 mm, right side
- **CHAIN-S** Snow chains
- **HOOK-SC** Snow chain hooks
- **TOWF-NO1** One front towing device
- **TOWF-NO2** Two front towing devices
- **TOWMBRH** Towing member, high mounted in centre of frame, D = 190
- **TOWMBRL1** Towing member, low mounted under the frame
- **TOWMBRL2** Towing member, low and forward mounted under the frame
- **TOWMBRL3** Towing member, low and far forward mounted under the frame
- **TOWMBRM** Towing member, medium mounted in line with frame lower flange
- **RFEC-L** Rear frame end, lower flange cut for centre axle drawbar.
- **RFEC-S** Rear frame end, straight cut for regular platform applications
- **RFEC-U** Rear frame end, upper cut for tipper applications.
- **C-RI4040** Towing coupling, Ringfeder 4040 G-150
- **C-RI5055** Towing coupling, Ringfeder 5055 G-150
- **C-RO400G** Towing coupling, Rockinger 400 G-150 for 40mm eyes
- **C-RO50** Rockinger RO 50 50mm for centre axle trailer
- **TOWR-ONE** Towing hitch attached to rear crossmember
- **TREL-PK** Trailer electrical preparation kit - chassis/cab wiring
- **TREL14** Single 14 pole electrical trailer connector
- **TREL15** Single 15 pole electrical trailer connector - ADR certified
- **TREL7** 7 pole - 24N trailer electrical suzie
- **TREL7-7** 24N and 24S trailer electrical suzies
- **TBC-DUO** Duomatic type air line connectors
- **TBC-EC** Palm coupling type air line connectors
- **TRBR-HCF** Full pressure hand controlled trailer brake
- **TRBR-STA** Stationary trailer brake control
- **TRB-STRE** Stretch Brake - Automatic low speed trailer brake activation to avoid jack-knifing and improve steerability
- **RUP-FOLD** Folding EC approved aluminium rear underrun
- **RUP-FOSL** Folding & sliding EC approved aluminium rear underrun
- **RFEND-B** Three piece EC approved rear mud wings and spray flaps
- **RFEND-T** Rear mud wings, transport mounted
- **RFH-BAS** Basic rear wing height
- **RFH-HIG** High rear wing height - higher wing tops
- **RFH-LOW** Lower rear wing height - shallower wing tops
- **ATANK-AL** Aluminium air tanks
- **ATANK-ST** Steel air tanks
- **TL-LED** Rear lights LED
- **BLIGHT-E** Emergency brake light

## WHEELS & TYRES

- **RT-AL** Alcoa brushed aluminium rims with standard holes for long stud fixing on all axles
- **RT-ALDP** Alcoa Dura-Bright EVO aluminium rims with standard holes long stud fixing on all axles, requires cleaning with a ph neutral solution - washing up liquid.
- **RT-ALDPD** Alcoa Dura-Bright EVO aluminium rims with countersunk holes for short stud fixing on all axles, requires cleaning with a ph neutral solution - washing up liquid.
- **RT-ALDU** Alcoa brushed aluminium rims with countersunk holes for short stud fixing on all axles
- **RT-STEEL** Steel rims on all axles
- **WCAP** Aerodynamic hub caps
- **BRREC001** Bridgestone ECOPIA H - Energy rating C
- **BRREC002** Bridgestone Ecopia H 002 Evo - Tyre recommendation 2
- **COREC001** Continental ECOPLUS HS3 XL/HD3 - Energy rating B or C depending on size
- **COREC002** Continental ECOPLUS HS3/HD3 - Energy rating B or C depending on size
- **COREC003** Continental Efficient Pro S/D - Fuel Tyre Recommendation 3 Reduced mileage compared to Conti EcoPlus long haul pattern please consider when selecting these tyres.
- **GYREC001** Goodyear FUELMAX S/HL/D - Energy rating B or C depending on size
- **GYREC002** Goodyear FUELMAX S/D - Energy rating B or C depending on size
- **GYREC004** Goodyear FUELMAX S - Energy rating B depending on size
- **HAREC001** Hankook AL10+ E-Cube Max Long Haul Tyre - Energy rating B
- **HAREC002** Hankook AL10+ E-Cube Long Haul Tyre - Energy rating B with wide single
- **MIREC001** Michelin XFA2/X-LINE Energy - Fuel tyre Recommendation 1
- **MIREC002** Michelin XZA2/X-LINE Energy - Fuel tyre Recommendation 2
- **MIREC003** Michelin X-LINE Energy - Fuel tyre Recommendation 3
- **MIREC004** Michelin X Line Energy F/D2 - Energy rating A
- **PIREC001** Pirelli FH:01 Proway - Long Haul Tyre - Energy rating B
- **PIREC002** Pirelli FH:01 II Long Haul Tyre - Energy rating B with wide single
- **SPWT-D** Spare wheel & tyre with rear tyre pattern
- **SPWT-F** Spare wheel & tyre with front tyre pattern
- **SWCP-R** Rear mounted spare wheel carrier
- **SWCP-T** Spare wheel supplied temporarily strapped to chassis
- **SWCP-TP** Temporary spare wheel carrier on top of chassis frame
- **JACK-12T** 12 tonne bottle jack
- **JACK-15T** 15 tonne bottle jack
- **JACK-20T** 20 tonne bottle jack
- **TOOL-BAS** Basic Toolkit
- **TOOLKIT** Complete tool kit
- **INFLAHOS** Tyre inflation hose

■ Standard Equipment

□ Optional Equipment

For more detailed information about cab and powertrain equipment, please refer to separate specification sheets.

For all possible options and combinations of options please consult your Volvo sales contact who can create a specification to match your requirements using the Volvo Sales Support system (VSS).

The factory reserves the right to modify design and change equipment without previous notification. The specification can vary from country to country.

# MODEL RANGE

## FH LNG 4x2 Rigid - Rear Air Suspension - Contact Regional Business Manager before

|   |   |   |  |
|---|---|---|--|
| <input type="checkbox"/> <b>GAUGE-TP</b>            | Tyre pressure gauge   | <input checked="" type="checkbox"/> <b>STWPOS-R</b> | RIGHT HAND DRIVE   |
| <b>DRIVELINE EQUIPMENT</b>                          |   | <input type="checkbox"/> <b>STWM-LE</b>             | Leather steering wheel   |
| <input type="checkbox"/> <b>TRAP-HD</b>             | Reinforced gearbox application  | <input type="checkbox"/> <b>STGW-AD2</b>            | Adjustable steering wheel with neck tilt   |
| <input type="checkbox"/> <b>TP-CON</b>              | Construction Package  | <input checked="" type="checkbox"/> <b>STGW-ADJ</b> | Adjustable steering wheel  |
| <input type="checkbox"/> <b>TP-DIST</b>             | Distribution Package  | <input checked="" type="checkbox"/> <b>AIRBAG</b>   | SRS Driver's air bag   |
| <input type="checkbox"/> <b>TP-LONG</b>             | Long Haul Package   | <input checked="" type="checkbox"/> <b>DRC-AMII</b> | DPF Regeneration control switch - for manual and switching off regeneration  |
| <input type="checkbox"/> <b>AMSO-AUT</b>            | Enhanced I-shift software with manual shift available in auto mode and kickdown facility on accelerator pedal   | <input type="checkbox"/> <b>1DAYDIG</b>             | Continental VDO DTCO 3.0 digital tachograph<br>This tachograph can ONLY offer remote download if the option of Dynafleet or an FMS gateway has been specified with this order.   |
| <input type="checkbox"/> <b>AVO-ENH</b>             | Enhanced software for off road driveability and starting  | <input type="checkbox"/> <b>1DAYDIGP</b>            | Continental VDO DTCO 3.0 digital tachograph<br>For vehicles with long lead time - this includes prep kit for the retrofit of DTCO 4.0 tachograph.<br>For updating to new legal demand for trick registration from 15th June 2019.<br>This tachograph can ONLY offer remote download if the option of Dynafleet or an FMS gateway has been specified with this order. |
| <input type="checkbox"/> <b>APF-ENH</b>             | I-shift enhanced PTO functions  | <input type="checkbox"/> <b>ARSL</b>                | Additional road speed limit - switch in dashboard  |
| <input type="checkbox"/> <b>RET-TH</b>              | Gearbox mounted retarder  | <input type="checkbox"/> <b>CRUISE-E</b>            | Eco cruise control (with eco-roll and I-cruise, controls in steering wheel)  |
| <input type="checkbox"/> <b>TC-MAO</b>              | Basic transmission oil cooler - air to oil  | <input checked="" type="checkbox"/> <b>CRUISEC</b>  | Cruise control, standard   |
| <input type="checkbox"/> <b>TC-MAOH2</b>            | Extra high performance transmission oil cooler - air to oil with front mounted radiator   | <input checked="" type="checkbox"/> <b>ESP-BAS1</b> | Electronic Stability Control   |
| <input type="checkbox"/> <b>2COM1100</b>            | Two cylinder, air compressor, 1100 litres per minute  | <input type="checkbox"/> <b>ESPC-RO</b>             | ESP (Electronic Stability Program) functionality control - Reduced / Off   |
| <input checked="" type="checkbox"/> <b>2COMP900</b> | Two cylinder, air compressor, 900 litres per minute   | <input type="checkbox"/> <b>HWSS-ACB</b>            | Adaptive cruise control ACC with forward collision warning and AEBS advanced emergency brake system  |
| <input type="checkbox"/> <b>CLU-AIRC</b>            | Clutchable air compressor   | <input checked="" type="checkbox"/> <b>HWSS-FCB</b> | Forward collision warning with AEBS advanced emergency brake system  |
| <input type="checkbox"/> <b>AIRIN-FR</b>            | Front air intake fitted to the underside of cab engine tunnel   | <input checked="" type="checkbox"/> <b>LSS-DW</b>   | Lane departure-warning system  |
| <input checked="" type="checkbox"/> <b>AIRIN-HI</b> | Roof mounted air intake behind cab on left hand side  | <input type="checkbox"/> <b>LCS</b>                 | Lane change support  |
| <input type="checkbox"/> <b>AIRIN-LO</b>            | Low level air intake behind cab on left hand side   | <input type="checkbox"/> <b>DAS-W</b>               | Driver Alert Support system  |
| <input type="checkbox"/> <b>ACL1ST-S</b>            | Two stage air filter  | <input type="checkbox"/> <b>RSENS-W</b>             | Rain sensing windscreen wipers   |
| <input checked="" type="checkbox"/> <b>24AL110B</b> | 110 amp alternator  | <input type="checkbox"/> <b>CU-ECC</b>              | Electrically controlled air conditioning with sun sensor   |
| <input type="checkbox"/> <b>24AL120B</b>            | 120 amp alternator  | <input type="checkbox"/> <b>CU-ECC2</b>             | Electrically controlled air conditioning with sun sensor, mist sensor, air quality sensor and carbon filter  |
| <input type="checkbox"/> <b>24AL150B</b>            | 150 amp alternator  | <input checked="" type="checkbox"/> <b>CU-MCC</b>   | Climate unit with manual controlled air conditioning   |
| <input type="checkbox"/> <b>PRIM-MAN</b>            | Manual priming pump   | <input checked="" type="checkbox"/> <b>IMMOBIL</b>  | Thatcham H2 approved immobiliser   |
| <input type="checkbox"/> <b>FUEFE2LW</b>            | Large engine mounted dual fuel filter with water separator  | <input type="checkbox"/> <b>ALARM-B</b>             | Thatcham H1 approved vehicle alarm - Cab only  |
| <input checked="" type="checkbox"/> <b>FUEFE2SW</b> | Small engine mounted dual fuel filter with water separator  | <input type="checkbox"/> <b>ALARM-E</b>             | Enhanced vehicle alarm - Thatcham H1 approved - Cab plus external sensor for body/trailer  |
| <input checked="" type="checkbox"/> <b>EST-AID</b>  | Air inlet manifold starting heater element  | <input type="checkbox"/> <b>ALCOLOCK</b>            | Alcolock   |
| <input type="checkbox"/> <b>220EBH15</b>            | 220V/1.5Kw electric engine block heater   | <input type="checkbox"/> <b>AMPL400</b>             | Radio amplifier, 8 channel, 400 W with subwoofer<br>Located in right hand external storage box   |
| <input type="checkbox"/> <b>PTER-DIN</b>            | Rear engine mounted PTO with DIN5462 (female) splined shaft for a close coupled pump.<br>Models with 3 steering axles will use this to drive the steering pump (AUXPSP) | <input type="checkbox"/> <b>BUPMON</b>              | Back up monitor with built in 7" screen on dash and one colour camera supplied loose for fitment by bodybuilder.<br>Can accommodate up to 4 cameras for TfL Safe Scheme, CLOCS and FORS.   |
| <input type="checkbox"/> <b>PTR-D</b>               | Gearbox PTO for plug-in pump, 0.71xeng speed  | <input type="checkbox"/> <b>PHONE-PK</b>            | Telephone preparation kit (antenna, antenna attachm. cable incl.)  |
| <input type="checkbox"/> <b>PTR-DH</b>              | Gearbox driven high speed PTO for one plug-in hydraulic pump  | <input checked="" type="checkbox"/> <b>WLIFT-AD</b> | Electrical window lift, automatic up/down driver side  |
| <input type="checkbox"/> <b>PTR-DM</b>              | Gearbox driven medium speed PTO for one plug-in hydraulic pump  | <input type="checkbox"/> <b>ISUNS-BS</b>            | Side interior sun visor on both sides  |
| <input type="checkbox"/> <b>PTR-F</b>               | Gearbox driven PTO with rear flange connection  | <input checked="" type="checkbox"/> <b>ISUNS-DS</b> | Driver's side interior sun visor   |
| <input type="checkbox"/> <b>PTR-FH</b>              | Gearbox driven high speed PTO with SAE drive flange   | <input type="checkbox"/> <b>ISUNF-RE</b>            | Electrically operated textile interior sun blind   |
| <input type="checkbox"/> <b>PTR-FL</b>              | Gearbox driven low speed PTO with SAE drive flange  | <input checked="" type="checkbox"/> <b>ISUNF-RM</b> | Manually operated textile interior sun blind   |
| <input type="checkbox"/> <b>PTRD-D</b>              | Gearbox driven HIGH SPEED PTO for two plug-in hydraulic pumps   | <input checked="" type="checkbox"/> <b>CSPL-BX</b>  | Lower center dash open storage box   |
| <input type="checkbox"/> <b>PTRD-D1</b>             | PTRD-D1 Gearbox driven HIGH SPEED PTO (1 SAE flange & 1 plug-in hydraulic pump)   | <input type="checkbox"/> <b>CSPL-BXD</b>            | Lower centre dash drawer   |
| <input type="checkbox"/> <b>PTRD-D2</b>             | Gearbox driven HIGH SPEED PTO (2 SAE flanges & 1 plug-in hyd pump)  |   |  |
| <input type="checkbox"/> <b>PTRD-F</b>              | PTO with 1 DIN + 1 flange connection rear, manual gearbox   |   |  |
| <input type="checkbox"/> <b>HPG-F101</b>            | Parker F1-101 gearbox mounted, fixed displacement, single flow, hydraulic pump  |   |  |
| <input type="checkbox"/> <b>HPG-F41</b>             | Parker F1-41 gearbox mounted, fixed displacement, single flow, hydraulic pump   |   |  |
| <input type="checkbox"/> <b>HPG-F51</b>             | Parker F1-51 gearbox mounted, fixed displacement, single flow, hydraulic pump   |   |  |
| <input type="checkbox"/> <b>HPG-F61</b>             | Parker F1-61 gearbox mounted, fixed displacement, single flow, hydraulic pump   |   |  |
| <input type="checkbox"/> <b>HPG-F81</b>             | Parker F1-81 gearbox mounted, fixed displacement, single flow, hydraulic pump   |   |  |
| <input type="checkbox"/> <b>EIDLESD</b>             | Engine idle shut down   |   |  |
| <input type="checkbox"/> <b>DTRI-PER</b>            | Dashboard in darker peregrine greyish brown. Steering wheel grey and door panels in light beige for FH and black for FH16.  |   |  |
| <input type="checkbox"/> <b>DTRI-SRA</b>            | Dashboard and steering wheel cover in light beige skylark. Door panels in light beige for FH and black for FH16.  |   |  |

Standard Equipment

Optional Equipment

For more detailed information about cab and powertrain equipment, please refer to separate specification sheets.

For all possible options and combinations of options please consult your Volvo sales contact who can create a specification to match your requirements using the Volvo Sales Support system (VSS).

The factory reserves the right to modify design and change equipment without previous notification. The specification can vary from country to country.

# MODEL RANGE

## FH LNG 4x2 Rigid - Rear Air Suspension - Contact Regional Business Manager before

- CSPU-SDR** One open storage and one drawer - behind push open lid - in upper part of the centre dash panel
- CSPU-SS** Two open storages - behind push open lid in upper part of the centre dash panel
- ADFS** Two extra DIN slots in front shelf - can be fitted with card or drawer available as an accessory
- BUPALARM** Reverse alarm
- RTOLL-PK** Road toll PREPARATION kit for trucks operating with "Toll Collect" in Germany
- LOADIND** Load indicator with central dashboard display
- REMC-MF** Multi-functio wireless remote control
- FIREXT3S** 3kg fire extinguisher mounted on seat base
- WARNVEST** High visibility warning vest - no sleeves
- AIDKIT** First aid kit
- AIDKIT1B** First aid kit
- WARNLAMP** Portable warning lamp
- LAMP-IN** Inspection lamp
- BULBKIT** Bulb and fuse kit
- WRITEPAD** Writing pad
- UPHTRIO1** Interior trim:  
Seats: Black embossed textile insert, black vinyl bolster with red vinyl side insert  
Cab walls: In matching grey vinyl
- UPHTRIO2** Interior trim:  
Seats: Black striped textile insert, black smooth textile bolster & red vinyl side insert  
Cab walls: Textile with matching grey nuances
- UPHTRIO3** Interior trim:  
Seats: Grey/beige soft striped textile insert, grey/beige smooth textile bolster  
Cab walls: soft textile in matching grey and beige colours
- UPHTRIO5** Interior trim:  
Seats: Light grey leather insert and black leather bolster  
Cab walls: In matching grey vinyl
- UPHTRIO6** Interior trim:  
Seats: Light grey leather insert and black leather bolster  
Cab walls: soft textiles in matching grey nuances
- UPHTRIO7** Interior trim:  
Seat: Light grey leather insert black edging  
Cab walls: soft textiles in matching grey, and beige
- DST-CF4** Driver seat, comfort, suspended, belt in seat
- DST-CF5** Driver seat, comfort, suspended, belt in seat, electrically heated
- DST-CF6** Driver seat, comfort, suspended, belt in seat, electrically heated, ventilated
- DST-LUX1** Deluxe suspended drivers seat features: electrical adjustment with memory function, seatbelt in seat with heated & ventilated cushions
- DST-LUX2** Deluxe suspended drivers seat features: electrical adjustment with memory function, seatbelt in seat and heated cushions
- SBD-RED** Red seat belts
- SBPRE-DS** Driver seat belt pretensioner
- PST-BAS1** Passenger seat - Fixed non suspended fold up with seatbelt mounted in cab
- PST-BSL1** Passenger seat - Sliding non suspended fold up with seatbelt mounted in cab
- PST-CF4** Passenger seat - Comfort suspended with seatbelt mounted in seat
- PST-CF5** Passenger seat - Comfort suspended & heated with seatbelt mounted in seat
- PST-RX1** Passenger seat - Fixed non suspended, features: 90 degree rotation and tilt function with seatbelt mounted in cab
- PST-RX2** Passenger seat - Fixed non suspended, features: 90 degree rotation, tilt and heated functions with seatbelt mounted in cab
- PST-STD2** Passenger seat - Fixed non suspended with seatbelt mounted in cab
- PST-STD4** Passenger seat - Standard suspended with seatbelt mounted in cab
- SBPRE-PS** Passenger seat belt pretensioner
- ARMRE-BB** Two armrests on both driver and passenger seat.
- ARMRE-DB** Two armrests, on driver seat only
- ARMRE-PB** Two armrests, on passenger seat only
- ARU-BAS** Vinyl upholstered armrest
- ARU-LEA** Leather upholstered armrest
- GRABHI-B** Steel instep cab grab handle
- GRABHI-L** Leather covered instep cab grab handle
- FMAT-RUB** Rubber floor mats
- FMAT-TX2** Textile and rubber floor mats
- LBK80F** Lower fixed bunk with wide middle section 815 in the centre x 2000 mm
- LBK80FRE** Lower electrically operated recline bunk with wide middle section 815 in the centre x 2000 mm
- LBK80FRM** Lower manually operated recline bunk with wide middle section 815 in the centre x 2000 mm
- MATL-FI** Firm lower bunk pocket sprung mattress
- MATL-SF** Lower flexizone mattress - semi-firm, pocket springs up to 100kg - 16 stone
- MATL-SO** Lower flexizone mattress - soft, pocket springs up to 85kg - 13.5 stone
- OLMAT-BA** 35mm mattress overlay protector
- OLMAT-PR** 50mm premium mattress overlay protector
- TBK60AD** Height adjustable foldable top bunk 600 x 1900mm
- TBK60F** Fixed foldable top bunk 600 x 1900mm
- TBK70AD** Height adjustable foldable top bunk 700 x 1900mm
- TBK70F** Fixed foldable top bunk 700 x 1900mm
- PH-CAB2** 1.8kW Air to air night heater
- PH-ENGCA** Engine and cab night heater
- CPC-ADV** I-ParkCool - Advanced cab parking cooler with 120V DC electrical compressor
- SLCP-BAS** Basic sleeper control panel - includes interior light, parking heater, roof hatch and door lock
- SLCP-LUX** Luxury sleeper control panel - includes interior light, parking heater, roof hatch, door lock, alarm clock, window and radio
- SAFE** Safe box for driver's personal items
- RUS-BAS** Rear cab upper storage 154 litres - 300 mm high
- RUS-HIG** Rear cab upper storage 245 litres - 440 mm high
- TABLE** Folding and height adjustable table - on lower bunk
- REFR-RUS** Fridge: 28 litre rear upper wall mounted with dividers
- REFRIG** Fridge: 33 litre under bunk mounted with freezer dividers
- MICRO-PK** Preparation kit for microwave oven (wiring)
- BOTH-D** One bottle holder under dashboard centre section
- BOTH-DL** Two bottle holders, one under dashboard centre section and one mounted to the under bunk drawer
- BOTH-L** One bottle holder mounted to the under bunk drawer
- COFMA-PK** Coffee maker, preparation kit.
- INLI-BAS** Interior white LED lights - basic
- INLI-NL** Interior white and red night LED light with no dimmer
- INLI-NLD** Interior white and red night LED light with dimmer
- ARL-FLEX** Two flexible reading lamps (snake lamps)
- RH-EE** Without roof hatch -Tinted glass emergency exit ONLY
- RH-ETR** Glass roof & escape hatch - Electrically operated, tinted glass with rear opening
- RH-MTR** Glass roof & escape hatch - Manually operated, tinted glass with rear opening
- URH** Without roof hatch
- SWIND-BS** Extra side window on both sides behind "B" pillar

Standard Equipment

Optional Equipment

For more detailed information about cab and powertrain equipment, please refer to separate specification sheets.

For all possible options and combinations of options please consult your Volvo sales contact who can create a specification to match your requirements using the Volvo Sales Support system (VSS).

The factory reserves the right to modify design and change equipment without previous notification. The specification can vary from country to country.

# MODEL RANGE

## FH LNG 4x2 Rigid - Rear Air Suspension - Contact Regional Business Manager before

- **VANMIR** Vanity mirror in front shelf
  - **AS-FUS** Extra shelf in front upper storage compartments
  - **INFOT-PK** Preparation kit for the mounting of a flat screen TV in cab above the driver's door, includes bracket, electrical and speaker connections
- ### CAB EXTERIOR
- **EXTL-BAS** Basic exterior finish - Matt Volvo badges, grey instep, bumper, bumper spoiler, mirror housing and sun visor
  - **EXTL-ENH** Enhanced exterior finish - Chrome style Volvo badges, painted instep, bumper, bumper spoiler if specified, mirror housing and sun visor
  - **GLAS-TIN** Tinted windows.
  - **DGLAS-H** Tempered door glass
  - **DGLAS-L** Laminated door glass
  - **LOCK-REM** Central locking with remote control
  - **BUMP-B** Plastic front bumper
  - **BUMP-B2** Steel front bumper
  - **BUMP-HD** Heavy duty front bumper
  - **BUMP-SP** Front bumper spoiler
  - **GUARD-EH** Engine guard to protect sump and engine hoses
  - **BUGNET** Insect screen in front of radiator
  - **CTILTP-E** Electrically operated hydraulic cab tilt
  - **CTILTP-M** Manually operated hydraulic cab tilt
  - **FCABS-A** Front cab suspension - Air
  - **FCABS-M** Front cab suspension - Mechanical spring
  - **RCABS-A** Rear cab suspension - Air
  - **RCABS-M** Rear cab suspension - Mechanical spring
  - **HCC-INEX** Exterior and interior hood catch control
  - **MIRCFPCS** Electrically heated and operated main and wide angle mirrors with manually adjusted kerb view mirror on passenger side and position camera in offside mirror arm.
  - **MIRCOMF** Electrically heated and operated main and wide angle mirrors and manually adjusted kerb view mirror on passenger side
  - **MIRSTD** Electrically heated main and wide angle mirrors and manually adjusted kerb view mirror on passenger side
  - **AMIR-F20** Auxiliary front view mirror with a 200mm radius
  - **SUNV-H** External smoke grey sunvisor
  - **AD-ROOF** Roof air deflector
  - **AD-SIDES** Short cab side air deflector for rigid bodywork
  - **HL-BASIC** Halogen H7 head lamps
  - **HL-BHID** High intensity Bi-Xenon head lamps
  - **HL-DBL** Bi-Xenon high intensity discharge and dynamic head lamps. Dipped beam follows the road, activated by a signal from the steering system.
  - **HL-CLEAN** Head lamp cleaner - washer jets
  - **HLP-ST** Headlamp protection
  - **HL-ADJ** Headlight adjustment - Switch in cab
  - **DRIVL2** Two spot lamps
  - **UDRIVL** Without auxiliary driving lights
  - **FOGL-WC** Front fog lights
  - **CL-STAT** Static corner lights
  - **ASL-RF2** Two Hella H11 70W spotlamps in sign box - only available with the basic headlight and no lower driving lights.
  - **BEACOA2F** Two front roof mounted amber beacon rotating warning lamps
  - **BEACOA2R** Two rear roof mounted (on accessory bracket) amber beacon flashing warning LED lamps
  - **BEACON-P** Roof beacon wire preparation
  - **BEACONA4** Four roof mounted (2 front/2 rear) amber beacon rotating warning lamps
  - **CABPT-R1** Single outlet for roof mounted accessories
  - **CABPT-R2** Twin outlets for roof mounted accessories.
  - **SPOTP-F** Spotlamp preparation in front, max 280W
  - **SPOTP-R** Spotlamp preparation on roof, max 280W
  - **SPOTP-RF** Spotlamp preparation on cab roof and in cab front, max 2x280W
  - **ROS-IL2** Preparation kit for illuminated roof sign with switch loose in cab, fit after registration
  - **CSGN-GTR** "Globetrotter" headboard logo
  - **HORN-F1S** Single tone Jericho air horn chassis mounted
  - **HORN-R2S** Two roof mounted air horns
  - **ANT-CBR** Roof mounted antenna for CB radio, single aerial
  - **ACCBR-AP** Front, middle & rear roof mounted accessory brackets
  - **ACCBR-F** Front roof mounted accessory bracket
  - **ACCBR-FM** Front & middle roof mounted accessory brackets
  - **ACCBR-FR** Front & rear roof mounted accessory brackets
  - **ACCBR-M** Middle roof mounted accessory bracket
  - **ACCBR-R** Rear roof mounted accessory bracket
  - **ACCBR-RM** Rear & middle roof mounted accessory brackets
  - **STUC-B** Left and right storage compartments under cab
  - **STUC-L** Left storage compartment under cab
  - **STUC-R** Right storage compartment under cab
  - **REFS-TW** White cab conspicuity markings by packed in cab
  - **REFS-TY** Yellow cab conspicuity markings by packed in cab
- ### SUPERSTRUCTURE PREPARATIONS
- **SRWL-PK** Wiring preparation for side & rear work/reverse lamps on side of chassis and a three-position switch, maximum 280W
  - **SWL-2FW** Two H3 70W white front chassis mounted (LH/RH side) working lamps and a 2-position switch (On/Off)
  - **SWL-2RW** Two H3 70W white rear chassis mounted (LH/RH side) working lamps and a 2-position switch (On/Off)
  - **SWL-4W** 4 H3 70W white front (2) & rear (2) chassis mtd (LH/RH side) working lamps & 2-pos switch (On/Off)
  - **SWL-PK** Wiring preparation for side work/reverse lamps on side of chassis and a three-position switch, maximum 280W
  - **WLC-H2W** Two H3/70W white working lamps high mounted on the back of cab
  - **WLC-PKCH** Preparation kit (cables and switch) for cab mounted chassis working lamp
  - **WLC-PKH** Preparation kit, cables and switch for high mounted working lamps back of cab
  - **WLC-PKL** Preparation kit, cables and switch for low mounted working lamps back of cab
  - **WLC-PKLH** Preparation kit - cables and switch for low and high mounted working lamps back of cab.
  - **ECBB-BAS** Body builder electrical centre without body builder module
  - **ECBB-HIG** Body builder electrical centre with body builder module
  - **BBCHAS1** One 7-pole connector for Body builder interface
  - **BBCHAS3** Three 7-pole connectors for Body builder interface
  - **BEPR-T2** Body builder electrical software preparation for tipper with remote control
  - **EXSTER** External steering control, with VDS and bodybuilder module
  - **TD-LED** Trailer detection with LED sensing
  - **FBA-BTF** Lower front body attachments for torsionally flexible - platform body
  - **FBA-BTSF** Lower front body attachments for torsionally semi-flexible body - box or curtainsider
  - **HBA-FSFB** Holes for body attachments - flexible/semi-flexible body
  - **HBA-SB** Holes for body attachments - stiff body
  - **RBA-T2** Lower rear body attachments for helper frame
  - **CRANEPK1** Crane plates mounted to frame, for cranes up to 10 tonne
- Standard Equipment      □ Optional Equipment

For more detailed information about cab and powertrain equipment, please refer to separate specification sheets.

For all possible options and combinations of options please consult your Volvo sales contact who can create a specification to match your requirements using the Volvo Sales Support system (VSS).

The factory reserves the right to modify design and change equipment without previous notification. The specification can vary from country to country.

# MODEL RANGE

FH LNG 4x2 Rigid - Rear Air Suspension - Contact Regional Business Manager before

---

- **CRANEPK2** metre capacity  
Crane plates mounted to frame, for cranes up to 20 tonne
- **CRANEPK4** metre capacity  
Crane plates mounted to frame, for cranes up to 40 tonne  
metre capacity
- **AUXL-SPK** Electrical preparation kit - wiring and switch for snow plough  
lights
- **TAILPRE2** Tail lift preparation kit, wireless remote operation
- **TAILPREP** Taillift preparation kit - cab switch and warning in driver display
- **AESW2** Two Body builder bistable electrical switches (marked AUX1 /  
AUX2)
- **AESW2PK** 2 Body builder bistable el.switches (marked AUX1/AUX2) and  
prep. for 4 more switches
- **AUXSW-4** Wiring for 4 extra switches (from Body builder electrical centre  
to switch positions)

## DELIVERY SERVICES

- **TGW-4GWL** GSM/GPRS/4G modem, LTE & WLAN for telematics gateway
- **FMS-PK** Fleet Management System gateway

**VOLVO**

Volvo Truck Corporation  
volvotrucks.com