

MODEL RANGE

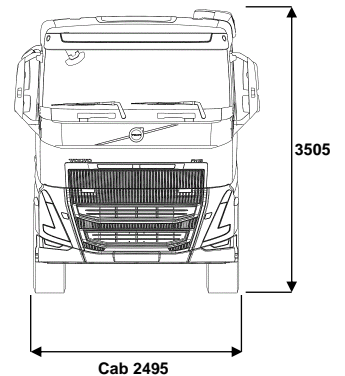

Volvo Trucks. Driving Progress

NEW FH 16 4x2 Rigid - Rear Air Suspension FH 42R 6A

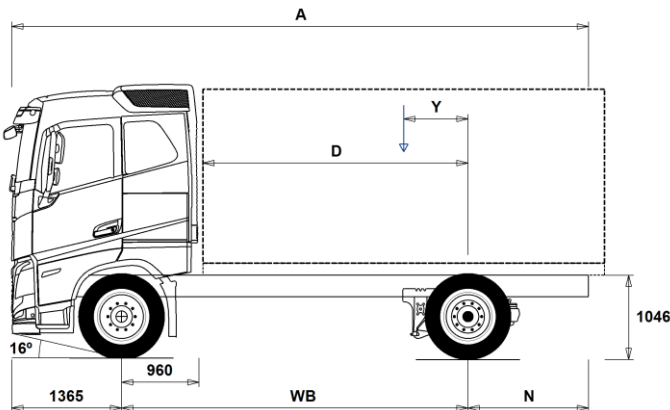

Chassis Dimensions [mm]

WB Wheelbase	3700	4000	4300	4600	4900	5200	5600	6000	6300	6500	6700
A Overall Chassis Length	8160	8460	8760	9060	9360	9660	10060	10460	10760	10960	11160
D Center of rear axle to front of body	2690	2990	3290	3590	3890	4190	4590	4990	5290	5490	5690
N Rear Overhang (Min.)	1395	1395	1395	1395	1395	1395	1395	1395	1395	1395	1395
N Rear Overhang (Max.)	3095	3095	3095	3095	3095	3095	3095	3095	3095	3095	3095
Y Center of Gravity for Payload (Min.)	471	505	540	575	610	646	718	729	758	781	797
Y Center of Gravity for Payload (Max.)	980	1058	1137	1215	1293	1372	1500	1575	1650	1702	1750

Chassis Weights [kg]

Front Axle	5115	5130	5140	5150	5160	5165	5120	5205	5225	5230	5245
Rear Axle	1990	2015	2040	2065	2080	2095	2130	2150	2180	2190	2210
Kerb Weight	7105	7145	7180	7215	7240	7260	7250	7355	7405	7420	7455
Payload (including body, driver, fuel, etc.)	10895	10855	10820	10785	10760	10740	10750	10645	10595	10580	10545

Turning Diameter [mm]

Turning Circle Diameter Kerb to Kerb	13900	14900	15900	16800	17800	18800	20000	21300	22300	22900	23600
Turning Circle Diameter Wall to Wall	15300	16200	17200	18100	19100	20100	21400	22600	23600	24300	24900

Plated Weights [kg]

	Plated	Design
Gross Vehicle Weight	18000	21000
Gross Combination Weight	40000	44000
Front Axle	8000	8000
Rear Axle	11500	13000

Important Notes

Chassis Dimensions

Cab Height: +305 mm for CAB-HSLP, -283 mm for CAB-LSLP, +450 mm for CAB-XHSL.

D-measure includes a front clearance of 50 mm and for rigid trucks also a subframe of 100 mm.

Height can vary ± 20 mm for leaf and ± 10 mm for air suspension.

All dimensions are for unladen chassis and any tag axles down. Chassis height used: CHH-HIGH.

Rear overhang used for vehicle weight calculation is the maximum rear overhang (N Max.) for selected wheelbase.

Height change when chassis height CHH-MED,FRAME266: 0 mm.

Weight and dimensions are based upon the following tyres:

Front Axle Tyres: 315/80R22.5

Drive Axle Tyres: 315/80R22.5

Chassis weight includes oil, water, AdBlue, 0 litres fuel and without driver. Kerb weight can vary $\pm 3\%$.

Turning diameters are theoretically calculated.

Legal weights can differ from country to country.

For more detailed weight information, including optional equipment weights, ask your Volvo sales contact to enter your specification into the Volvo Weight Information system (WIS).

Do NOT use this drawing for bodybuilding. Refer to Volvo Bodybuilder Instructions and chassis assembly drawing FH42R6A.

MODEL RANGE

NEW FH 16 4x2 Rigid - Rear Air Suspension FH 42R 6A

TRUCK USE

- RC-ROUGH** Road conditions - On / off-road
- RC-SMOOTH** Road Conditions - Smooth

CORE COMPONENTS

- CHH-HIGH** Chassis Height - High - for loading heights check the unique BEP chassis drawing
- CHH-MED** Chassis Height - Medium - for loading heights check the unique BEP chassis drawing
- RAD-GR** RAD-GR - 4x2 Air - High
- FH16HSL5** Globetrotter cab - all steel safety cage design with roof mounted emergency escape hatch. Designed and built to Swedish impact and ECE R29 regulations
- FH16LSL5** Low Sleeper Cab
- FH16SLP5** Cab - Sleeper - all-steel safety cage design with roof-mounted emergency escape hatch. Designed and built to Swedish impact and ECE R29 regulations
- FH16XHS5** Globetrotter XL cab - all steel safety cage design with roof mounted emergency escape hatch. Designed and built to Swedish impact and ECE R29 regulations
- EU6DS** Euro 6 SCR, particulate filter, EGR and dual stage turbo
- D16K550** Engine - D16K550 16 litre developing 550hp at 1550-1900rpm SCR & EGR. Peak torque 2900Nm at 900-1350rpm. 2800Nm at 900-1400rpm with manual gearbox
- D16K650** Engine - D16K650 16 litre developing 650hp at 1450-1900rpm SCR & EGR. Peak torque 3150Nm at 950-1450rpm.
- D16K750** Engine - D16K750 16 litre developing 750hp at 1600-1800rpm SCR & EGR. Peak torque 3550Nm at 950-1400rpm.
- EBR-EPG** Engine Brake Type - Exhaust brake controlled by steering column switch
- EBR-VEB+** Engine Brake Type - Volvo engine brake + and exhaust pressure governor, enhanced performance from additional exhaust rocker control. Retardation 375kW
- AT2812F** Gearbox - AT2812E 12-speed "I-shift" automated mechanical suitable for gross train weights up to 60 tonne. Refer to sales engineering when used in conjunction with a PTO
- ATO3112F** Gearbox - ATO3112F 12-speed "I-shift" overdrive automated mechanical, suitable for gross train weights up to 60tonne. Refer to sales engineering when used in conjunction with a PTO
- ATO3512F** ATO3512F 12-speed "I-shift" automated mechanical, suitable for gross train weights up to 60 tonne. Refer to sales engineering when used in conjunction with a PTO
- RSH1370F** Drive Axle - RSH1370F 13-tonne hub reduction with differential lock - design GCW 70 tonne
- RSS1370A** Drive Axle - RSS1370A single reduction 13 tonne with differential lock - design GCW 70 tonne
- RSS1370B** Drive Axle - RSS1370B single reduction 13 tonne with differential lock - design GCW 70 tonne

PACKAGES

- FUELPACK** Fuel Package - Long haul
- DRIVE16** Drive + Package
- 1LIVIN++** Sleep & Resting Package - Living one-bed ++
- 1LIVING** Sleep & Resting Package - Living one-bed
- 1LIVING+** Sleep & Resting Package - Living one-bed +
- 2LIVIN++** Sleep & Resting Package - Living two-bed ++
- 2LIVING** Sleep & Resting Package - Living two-bed
- 2LIVING+** Sleep & Resting Package - Living two-bed +
- INFOBAS** Basic media package without secondary display
- INFODF** Media Information Platform with Dynafleet Support
- INFOMED** Media Information Platform - Medium level

■ Standard Equipment

□ Optional Equipment

For more detailed information about cab and powertrain equipment, please refer to separate specification sheets.

For all possible options and combinations of options please consult your Volvo sales contact who can create a specification to match your requirements using the Volvo Sales Support system (VSS).

The factory reserves the right to modify design and change equipment without previous notification. The specification can vary from country to country.

- INFONAV** Media Information Platform with Navigation
 - INFONDF** Media Information Platform with Navigation & Dynafleet Support
 - VISI5** Visibility Package
 - VISI5+** Visibility plus Package
 - VISI5++** Visibility ++ Package
 - VISIC5** Visibility Package
 - VISIC5+** Visibility plus Package
 - SAFE-VE** Active Safety Package
 - SAFE-VE+** Active Safety + Package
 - CHASPAC** Chassis Package Rigid
- ### CHASSIS
- FST-AIR** Front suspension type - Air
 - FST-PAR** Front suspension type - 2 leaf parabolic springs
 - FST-PAR3** Front suspension type - 3 leaf parabolic springs
 - FSL5-BAS** Front suspension levelling - basic stroke
 - FSL5-HI** Front suspension levelling - high stroke for demount operations - check with bodybuilder
 - FAL10.0** Front axle design capacity - 10 tonne - check tyre capacity
 - FAL7.5** Front axle design capacity - 7.5 tonne
 - FAL8.0** Front axle design capacity - 8.0 tonne - check tyre capacity
 - FAL8.5** Front axle design capacity - 8.5 tonnes
 - FAL9.0** Front axle design capacity - 9.0 tonne - check tyre capacity
 - FSM-LUB** Front suspension maintenance - Lubricated rear shackles on pins and bushings
 - FSTAB** Front anti-roll bar - Normal stiffness
 - FSTAB2** Front anti-roll bar - Medium stiffness
 - FSTAB3** Front anti-roll bar - High stiffness
 - RAL11.5** Rear axle design capacity - 11.5 tonne
 - RAL13** Rear axle design capacity - 13 tonne
 - ASF-DL1** Air suspension with 1 driving level
 - ASF-DL3** Air suspension with 3 driving levels
 - ACTST-TO** Active Steering- Volvo Dynamic Steering - VDS - with extra electronic pump and torque overlay
 - ASFE-BAS** Active steering feature - Basic - Volvo Dynamic Steering - VDS - only
 - ASFE-OG** Active steering feature - Volvo Dynamic Steering - VDS - with stability assist - oversteer
 - ASFE-PO** Active steering feature - Volvo Dynamic Steering - VDS - with personal settings and stability assist
 - ASFE-PS** Active steering feature - Volvo Dynamic Steering - VDS - with personal settings
 - PSP-FIX** Power steering pump - Fixed displacement
 - PSP-VAR** Power steering pump - Variable displacement
 - EBS-MED** Brake package - EBS medium including "hill" hold function
 - AUXPARK** Auxiliary parking brake - Additional spring brakes
 - FRAME266** Chassis frame section external height - 266 mm
 - FRAME300** Chassis frame section external height - 300 mm
 - FST6060** Chassis frame thickness - 6 mm web and flange
 - FST7070** Chassis frame thickness - 7 mm web and flange
 - FST8080** Chassis frame thickness - 8 mm web and flange
 - FIL-EEEB** Chassis frame inner liner - From the end of the engine to the end of the bogie
 - FIL-EEEF** Chassis frame inner liner - From the end of the engine to end of the frame
 - FIL-TXEB** Chassis frame inner liner - From gearbox member to the end of the bogie
 - FIL-TXEF** Chassis frame inner liner - From gearbox member to the end of the frame
 - BATS-D** Dual energy battery system - 2 living batteries and 2 starter batteries.
 - BATS-S** Single energy battery system (2 batteries)
 - 2BAT210B** Battery Capacity - 2 x 210 Ah - Gel type

MODEL RANGE

NEW FH 16 4x2 Rigid - Rear Air Suspension FH 42R 6A

- **2BAT210C** Battery Capacity - 2 x 210 Ah - AGM Absorbent Glass-fibre Material type
- **2BATT170** Battery Capacity - 2 x 170 Ah on the left-hand side
- **BATTAMP** Battery management - Voltage and current gauge
- **BATTIND** Battery management - Charge indicator
- **ADR2** ADR Adaptation - For transportation of dangerous goods on the road - Note does NOT include safe loading pass package if required this is quoted separately
- **MSWI-A** Battery master switch - ADR switch circuit shut down
- **MSWI-C** Battery master switch - Chassis mounted toggle by the battery box
- **MSWI-R** Battery master switch - Key fob operated remote controlled
- **R330A71** Right fuel tank - 330litre aluminium diameter 710mm
Min volume 255l
Max volume 885l
- **UL-FUEL** Without left fuel tank
Min volume 160l
Max volume 730l
- **ADTP-L** AdBlue tank position - Chassis mounted on the left-hand side
- **ADTP-R** AdBlue tank position - Chassis mounted on the right-hand side
- **ADB048** Plastic AdBlue tank - 48 litre
- **ADB064** Plastic AdBlue tank - 64 litre
- **ADB068** Plastic AdBlue tank - 68 litre
- **ADB090** Plastic AdBlue tank - 90 litre
- **ADB100** Plastic AdBlue tank - 100 litre
- **ADTC-BF** AdBlue tank cover with satin alloy look decorative cover
- **FCAP-L** Diesel and AdBlue filler cap - Locking
- **FUFF-AS** Fuel filler - Anti-spill device
- **FUFF-ATS** Fuel filler - Anti-spill & anti-syphon device
- **ESH-LEFT** Exhaust - Horizontal silencer - left outlet
- **ESH-REAR** Exhaust - Horizontal silencer - rear outlet
- **ESH-RIGH** Exhaust - Horizontal silencer - right outlet
- **ESH-VERT** Exhaust - Horizontal silencer - vertical outlet
- **EXST-SSP** Stainless steel exhaust stack - NOT polished
- **EXST-ST** Steel exhaust stack
- **WHC-FIX1** Wheel chock - One fixed design
- **WHC-FIX2** Wheel chocks - Two fixed design
- **WHC-FOL1** One foldable wheel chock
- **WHC-FOL2** Two foldable wheel chocks
- **WHCP-F** Wheel chock carrier position - In the front part of the vehicle
- **WHCP-M** Wheel chock carrier position - Middle part of the vehicle
- **WHCP-R** Wheel chock carrier position - In the rear part of the vehicle
- **WHCP-T** Wheel chock carrier position - Outer luggage locker
- **TB-R80** Toolbox 800 mm, right side
- **SUP-BAS** EC approved chassis side guards
- **CHAIN-S** Snow chains
- **HOOK-SC** Snow chain hooks
- **TOWF-NO1** Front towing device - One detachable - stored in cab
- **TOWF-NO2** Front towing device - Two detachable - stored in cab
- **TOWMBRH** Towing member, high mounted in centre of frame, D = 190
- **TOWMBRL1** Towing member, low mounted under the frame
- **TOWMBRL2** Towing member, low and forward mounted under the frame
- **TOWMBRL3** Towing member, low and far forward mounted under the frame
- **TOWMBRM** Towing member, medium mounted in line with frame lower flange
- **RFEC-L** Rear frame profile - Lower flange cut for centre axle drawbar
- **RFEC-S** Rear frame profile - Straight cut
- **RFEC-U** Rear frame profile - Slight uppercut for tippers
- **C-RI4040** Towing coupling, Ringfeder 4040 G-150
- **C-RI5055** Towing coupling, Ringfeder 5055 G-150
- **C-RO400G** Towing coupling, Rockinger 400 G-150 for 40mm eyes
- **C-RO50** Rockinger RO 50 50mm for centre axle trailer
- **TOWR-ONE** Towing hitch attached to rear crossmember
- **TREL-PK** Trailer electrical preparation kit - chassis/cab wiring
- **TREL14** Single 14 pole electrical trailer connector
- **TREL15** Trailer electrical connection - Single 15 pin - ADR certified
- **TREL7** 7 pole - 24N trailer electrical suzie
- **TREL7-7** Trailer electrical connection - 2 x 7 pin - 24N and 24S
- **TBC-DUO** Duomatic type air line connectors
- **TBC-EC** Trailer brakes with EC palm coupling connectors
- **TRBR-HCF** Full pressure hand controlled trailer brake
- **TRBR-STA** Stationary trailer brake control
- **TRB-STRE** Stretch Brake - Automatic low speed trailer brake activation to avoid jack-knifing and improve steerability
- **RUP-FOLD** Rear underrun protection - Aluminium folding EC approved
- **RUP-FOSL** Rear underrun protection - Aluminium folding & sliding EC approved
- **RFEND-B** Three piece EC approved rear mud wings and spray flaps
- **RFEND-T** Rear mud wings - Temporary on drive axle for transport delivery only
- **RFH-BAS** Basic rear wing height
- **RFH-HIG** High rear wing height - higher wing tops
- **RFH-LOW** Lower rear wing height - shallower wing tops
- **ATANK-AL** Air tanks - Aluminium
- **ATANK-ST** Air tanks - Steel
- **TL-LED** Rear lights - LED
- **BLIGHT-E** Emergency brake light

WHEELS & TYRES

- **RT-AL** Wheels - Alcoa brushed aluminium rims - standard holes for long stud fixing
- **RT-ALDP** Wheels - Alcoa Dura-Bright aluminium rims - standard holes for long stud fixing
- **RT-ALDPD** Wheels - Alcoa Dura-Bright EVO aluminium rims - countersunk holes for short stud fixing
- **RT-ALDU** Wheels - Alcoa brushed aluminium rims - countersunk holes for short stud fixing
- **RT-STEEL** Wheels - Steel rims
- **WCAP** Aerodynamic hub caps
- **SPWT-D** Spare wheel & tyre with rear tyre pattern
- **SPWT-F** Spare wheel & tyre with front tyre pattern
- **SWCP-LF** Spare wheel carrier on left side of chassis ahead of rear axle
- **SWCP-R** Rear mounted spare wheel carrier
- **SWCP-T** Spare wheel supplied temporarily strapped to chassis
- **SWCP-TP** Temporary spare wheel carrier on top of chassis frame
- **JACK-12T** 12 tonne bottle jack
- **JACK-15T** 15 tonne bottle jack
- **JACK-20T** 20 tonne bottle jack
- **TOOL-BAS** Basic Toolkit
- **TOOLKIT** Complete tool kit
- **INFLAHOS** Tyre inflation hose
- **GAUGE-TP** Tyre pressure gauge

DRIVELINE EQUIPMENT

- **TRAP-HD** Reinforced gearbox application
- **DRM-BE** Balanced & Economy Drive Mode
- **PVT-MAP** I-See Predictive Cruise Control - using map based topography information
- **CRUIS-E** Eco cruise control (with eco-roll and I-cruise, controls in steering wheel)
- **CRUISEC** Cruise control, standard
- **AMSO-AUT** Enhanced I-shift software with manual shift available in auto mode and kickdown facility on accelerator pedal
- **AVO-ENH** I-Shift application software - Off-road

■ Standard Equipment

□ Optional Equipment

For more detailed information about cab and powertrain equipment, please refer to separate specification sheets.

For all possible options and combinations of options please consult your Volvo sales contact who can create a specification to match your requirements using the Volvo Sales Support system (VSS).

The factory reserves the right to modify design and change equipment without previous notification. The specification can vary from country to country.

MODEL RANGE

NEW FH 16 4x2 Rigid - Rear Air Suspension FH 42R 6A

- | | |
|---|--|
| <ul style="list-style-type: none"> □ APF-ENH I-shift enhanced PTO functions □ RET-TH Gearbox mounted retarder □ TC-MAOH2 Extra high performance transmission oil cooler - air to oil with front mounted radiator □ TC-MWO Basic transmission oil cooler - water to oil □ 2COM1100 Air compressor - Two-cylinder 1100 litres per minute ■ 2COMP900 Air compressor - Two-cylinder 900 litres per minute □ CLU-AIRC Clutchable air compressor □ AIRIN-FR Front air intake fitted to the underside of cab engine tunnel ■ AIRIN-HI Air intake - Roof-mounted behind cab on the left-hand side □ AIRIN-LO Low level air intake behind cab on left hand side □ ACL1ST-S Air filter - two-stage element ■ 24AL120B Alternator capacity - 120 amp alternator ■ 24AL150B Alternator capacity - 150 amp □ CCV-C Closed crankcase engine ventilation ■ CCV-OX Closed crankcase ventilation for cold markets ■ PRIM-EL Electrical priming pump □ AF-R Hot fuel recirculation heated fuel filter ■ FUEFE2SW Small engine mounted dual fuel filter with water separator □ EST-AID Engine starting aid -Preheating element in the air inlet manifold □ 220EBH15 220V/1.5Kw electric engine block heater □ PTER-100 Engine power-take-off - Rear-mounted with DIN100/ISO7646 flange □ PTER-DIN Engine power-take-off - Rear-mounted with DIN5462 (female) splined shaft for a close-coupled pump
Models with 3 steering axles will use this to drive the steering pump (AUXPSP) □ PTER1400 Engine power-take-off - Rear-mounted with SAE 1410 flange □ HPE-F101 Parker F1-101, engine mounted, fixed displacement, single flow, engine mounted hydraulic pump □ HPE-F41 Parker F1-41, engine mounted, fixed displacement, single flow, engine mounted hydraulic pump □ HPE-F51 Parker F1-51, engine mounted, fixed displacement, single flow, engine mounted hydraulic pump □ HPE-F61 Parker F1-61, engine mounted, fixed displacement, single flow, engine mounted hydraulic pump □ HPE-F81 Parker F1-81, engine mounted, fixed displacement, single flow, engine mounted hydraulic pump □ HPE-T53 Parker F2-53/53, engine mounted, Fixed displacement, Twin flow engine mounted hydraulic pump □ HPE-T70 Parker F2-70/35, engine mounted, Fixed displacement, Twin flow engine mounted hydraulic pump □ HPE-V45 Parker VP1-45, variable displacement, single flow, engine mounted hydraulic pump □ HPE-V75 Parker VP1-75, variable displacement, single flow, engine mounted hydraulic pump □ PTR-D Gearbox PTO for plug-in pump, 0.71xeng speed □ PTR-DH Gearbox driven high speed PTO for one plug-in hydraulic pump □ PTR-DM Gearbox driven medium speed PTO for one plug-in hydraulic pump □ PTR-F Gearbox driven PTO with rear flange connection □ PTR-FH Gearbox driven high speed PTO with SAE drive flange □ PTR-FL Gearbox driven low speed PTO with SAE drive flange □ PTRD-D Gearbox driven HIGH SPEED PTO for two plug-in hydraulic pumps □ PTRD-D1 PTRD-D1 Gearbox driven HIGH SPEED PTO (1 SAE flange & 1 plug-in hydraulic pump) □ PTRD-D2 Gearbox driven HIGH SPEED PTO (2 SAE flanges & 1 plug-in hyd pump) □ PTRD-F PTO with 1 DIN + 1 flange connection rear, manual gearbox □ HPG-F101 Parker F1-101 gearbox mounted, fixed displacement, single flow, hydraulic pump □ HPG-F41 Parker F1-41 gearbox mounted, fixed displacement, single flow, hydraulic pump | <ul style="list-style-type: none"> □ HPG-F51 Parker F1-51 gearbox mounted, fixed displacement, single flow, hydraulic pump □ HPG-F61 Parker F1-61 gearbox mounted, fixed displacement, single flow, hydraulic pump □ HPG-F81 Parker F1-81 gearbox mounted, fixed displacement, single flow, hydraulic pump ■ STWPOS-R Steering wheel position - RIGHT-HAND DRIVE ■ STWM-LE Leather steering wheel □ STGW-AD2 Adjustable steering wheel with neck tilt ■ STGW-ADJ Adjustable steering wheel ■ AIRBAG SRS Driver's air bag ■ DRC-AMII DPF Regeneration control switch - for manual and switching off regeneration ■ 1DAYDIG2 Tachograph - Continental VDO 4.0 □ ARSL Additional road speed limit - switch in dashboard ■ ESP-BAS1 Electronic Stability Control □ ESPC-RO ESP (Electronic Stability Program) functionality control - Reduced / Off □ HWSS-ACB Adaptive cruise control ACC with forward collision warning and AEBS advanced emergency brake system ■ HWSS-FCB Forward collision warning with AEBS advanced emergency brake system ■ LSS-DW Lane departure-warning system □ LCS Lane change support □ DAS-W Driver Alert Support system □ RSENS-W Rain sensing windscreen wipers ■ CU-ECC Cab Climate Unit - Electrically controlled air conditioning with sun sensor □ CU-ECC2 Cab Climate Unit - Electrically controlled air conditioning with a carbon filter, sun, mist, and air quality sensor ■ IMMOBIL Thatcham H2 approved immobiliser □ ALARM-E Enhanced vehicle alarm - Thatcham H1 approved - Cab plus external sensor for body/trailer □ ALCOLOCK Alcolock □ AMPL400 Radio amplifier, 8 channel, 400 W with subwoofer
Located in right hand external storage box □ BUPMON CLASSIC Video switch & one reverse camera & lead - NEW
Digital reverse camera, parameter & lead supplied loose in cab. □ PHONE-PK Telephone preparation kit (antenna, antenna attachm. cable incl.) □ ISUNS-BS Side sun visor - Driver & passenger side ■ ISUNS-DS Side sun visor - Driver-side □ ISUNF-RE Electrically operated textile interior sun blind ■ ISUNF-RM Manually operated textile interior sun blind ■ CSPL-BX Lower center dash open storage box □ CSPL-BXD Lower centre dash drawer □ CSPU-SDR One open storage and one drawer - behind push open lid - in upper part of the centre dash panel ■ CSPU-SS Two open storages - behind push open lid in upper part of the centre dash panel □ ADFS Two extra DIN slots in front shelf - can be fitted with card or drawer available as an accessory ■ BUPALARM Reverse alarm □ RTOLL-PK Road toll PREPARATION kit for trucks operating with "Toll Collect" in Germany □ LOADIND Load indicator with central dashboard display □ REMC-MF Multi-functio wireless remote control |
|---|--|

■ Standard Equipment

□ Optional Equipment

For more detailed information about cab and powertrain equipment, please refer to separate specification sheets.

For all possible options and combinations of options please consult your Volvo sales contact who can create a specification to match your requirements using the Volvo Sales Support system (VSS).

The factory reserves the right to modify design and change equipment without previous notification. The specification can vary from country to country.

MODEL RANGE

NEW FH 16 4x2 Rigid - Rear Air Suspension FH 42R 6A

- FIREXT3S** Fire extinguisher - 3kg mounted on the seat base
- WARNVEST** High visibility warning vest - no sleeves
- AIDKIT** First aid kit - Legal demand for EU markets including delivery to EU bodybuilder
- AIDKIT1B** First aid kit - Legal demand for trucks transiting Germany
- WARNLAMP** Portable warning lamp
- LAMP-IN** Inspection lamp
- BULBKIT** Bulb and fuse kit
- WRITEPAD** Writing pad
- DST-CF4** Driver seat - Suspended, adjustable shock absorber, travel, backrest & lumbar controls - seatbelt mounted to the seat
- DST-CF5** Driver seat - Suspended with adjustable shock absorber, travel, backrest, lumbar & heat controls - seatbelt mounted to the seat
- DST-CF6** Driver seat - Suspended with adjustable shock absorber, travel, backrest, lumbar, heat and ventilation controls - seatbelt mounted to the seat
- DST-LUX1** Driver seat - Deluxe 1: electrical adjustment with memory function, lumbar support, heating & ventilation - seatbelt mounted to the seat
- DST-LUX2** Driver seat - Deluxe 2: electrical adjustment with memory function, lumbar support & heating - seatbelt mounted to the seat
- SBD-RED** Seat belt colour - Red
- SBPRE-DS** Driver seat belt pretensioner
- PST-BAS1** Passenger seat - Fixed non suspended fold up with seatbelt mounted in cab
- PST-CF4** Passenger seat - Suspended, adjustable shock absorber, travel, backrest & lumbar controls - seatbelt mounted to the seat
- PST-CF5** Passenger seat - Suspended with adjustable shock absorber, travel, backrest, lumbar & heat controls - seatbelt mounted to the seat
- PST-RX1** Passenger seat - Fixed non suspended, features: 90-degree rotation and tilt function with seatbelt mounted in cab
- PST-STD2** Passenger seat - Fixed with backrest adjustment, non suspended with seatbelt mounted in cab
- PST-STD4** Passenger seat - Standard suspended with seatbelt mounted in cab
- SBPRE-PS** Passenger seat belt pretensioner
- ARMRE-BB** Armrests - Two on both driver & passenger seats
- ARU-LEA** Armrest upholstery - Leather
- GRABHI-L** Leather covered instep cab grab handle
- FMAT-RUB** Footwell floor mats - Rubber
- FMAT-TX2** Footwell floor mats - Two sets, Rubber and textile with an embossed pile supplied in the cab
- LBK80F** Lower fixed bunk with wide middle section 815 in the centre x 2000 mm
- LBK80FRE** Lower electrically operated recline bunk with wide middle section 815 in the centre x 2000 mm
- LBK80FRM** Lower manually operated recline bunk with wide middle section 815 in the centre x 2000 mm
- MATL-FI** Firm lower bunk pocket sprung mattress
- MATL-FI4** Lower mattress - firm, memory foam, 2000x700x130 mm
- MATL-SF** Lower flexizone mattress - semi-firm, pocket springs up to 100kg - 16 stone
- OLMAT-BA** 35mm mattress overlay protector
- OLMAT-PR** 50mm premium mattress overlay protector
- TBK60AD** Height adjustable foldable top bunk 600 x 1900mm
- TBK60F** Fixed foldable top bunk 600 x 1900mm
- TBK70AD** Height adjustable foldable top bunk 700 x 1900mm
- TBK70F** Fixed foldable top bunk 700 x 1900mm
- PH-CAB2** 1.8kW Air to air night heater
- PH-ENGCA** Engine and cab night heater
- CPC-ADV** I-ParkCool - Advanced cab parking cooler with 120V DC electrical compressor
- SLCP-BAS** Sleeper control panel - Basic with switches for interior light, night heater, roof hatch and door lock
- SLCP-LUX** Sleeper control panel - Luxury with switches for interior light, night heater, roof hatch, door lock, alarm clock, window and radio
- SAFE** Safe box for driver's personal items
- RUS-BAS** Rear cab upper storage - 300 mm high
- RUS-HIG** Rear cab upper storage - 440 mm high - volume 245 litres
- TABLE** Folding and height adjustable table - on lower bunk
- REFR-RUS** Fridge - 28 litre rear upper wall mounted with dividers
- REFRIG** Fridge - 33 litre under-bunk mounted with freezer dividers
- MICRO-PK** Wiring preparation kit for microwave oven
- BOTH-D** One bottle holder under dashboard centre section
- BOTH-DL** Two bottle holders, one under dashboard centre section and one mounted to the under bunk drawer
- BOTH-L** One bottle holder mounted to the under bunk drawer
- COFMA-PK** Coffee maker, preparation kit.
- INLI-BAS** Interior white LED lights - basic
- INLI-NL** Interior white and red night LED light with no dimmer
- INLI-NLD** Interior white and red night LED light with dimmer
- ARL-FLEX** Two flexible reading lamps (snake lamps)
- RH-EE** Fixed tinted glass sky window with emergency exit
- RH-ER** Steel roof hatch - Electrically operated, rear opening with emergency exit
- RH-ETR** Tinted glass roof hatch - Electrically operated, rear opening with emergency exit
- RH-MTR** Tinted glass roof hatch - Manually operated, rear opening with emergency exit
- GLAS-TIN** Tinted windows.
- SWIND-BS** Extra side window on both sides behind "B" pillar
- VANMIR** Vanity mirror in front shelf
- AS-FUS** Extra shelf in front upper storage compartments
- INFOT-PK** Preparation kit for the mounting of a flat screen TV in cab above the driver's door, includes bracket, electrical and speaker connections

CAB EXTERIOR

- EXTL-BAS** Basic exterior finish - Satin Volvo badges, grey grille, instep, bumper, bumper spoiler, grille, door handles mirror housing and sunvisor if specified.
- EXTL-EN3** Enhanced exterior finish - Waterfall Grille. Chrome Volvo badges and door handles. Instep, bumper and bumper spoiler in cab colour if specified. Aluminium step inserts. Mirror housing and sun visor if specified with silver accents.
- DGLAS-H** Tempered door glass
- DGLAS-L** Laminated door glass
- LOCK-REM** Door locks - Remote central locking
- BUMP-B** Plastic front bumper
- BUMP-B2** Steel front bumper
- BUMP-HD** Heavy duty front bumper
- BUMP-SP** Front bumper spoiler
- GUARD-EH** Engine guard to protect sump and engine hoses
- BUGNET** Insect screen in front of radiator
- CTILT-P-E** Electrically operated hydraulic cab tilt
- CTILT-P-M** Manually operated hydraulic cab tilt
- FCABS-A** Front cab suspension - Air
- FCABS-M** Front cab suspension - Mechanical spring

■ Standard Equipment

□ Optional Equipment

For more detailed information about cab and powertrain equipment, please refer to separate specification sheets.

For all possible options and combinations of options please consult your Volvo sales contact who can create a specification to match your requirements using the Volvo Sales Support system (VSS).

The factory reserves the right to modify design and change equipment without previous notification. The specification can vary from country to country.

MODEL RANGE

NEW FH 16 4x2 Rigid - Rear Air Suspension FH 42R 6A

- RCABS-A** Rear cab suspension - Air
- RCABS-M** Rear cab suspension - Mechanical spring
- HCC-INEX** Exterior and interior hood catch control
- MIRCFPCPS** Mirrors - Electrically heated and operated main and wide-angle with manually adjusted kerb view mirror on the passenger side and position camera in nearside mirror arm.
- MIRCOMF** Electrically heated and operated main and wide angle mirrors and manually adjusted kerb view mirror on passenger side
- MIRSTD** Electrically heated main and wide angle mirrors and manually adjusted kerb view mirror on passenger side
- AMIR-F20** Auxiliary front view mirror with a 200mm radius
- SUNV-H** External smoke grey sunvisor
- AD-ROOF** Roof air deflector
- AD-SIDES** Short cab side air deflector for rigid bodywork
- HL-BASIC** Halogen H7 head lamps
- HL-CLEAN** Head lamp cleaner - washer jets
- HLP-ST** Headlamp protection
- HL-ADJ** Headlight adjustment - Switch in cab
- DRIVL2** Two spot lamps
- UDRIVL** Without auxiliary driving lights
- FOGL-WC** Front fog lights
- CL-STAT** Static corner lights
- ASL-RF2** Two Hella H11 70W spotlamps in sign box - only available with the basic headlight and no lower driving lights.
- BEACOA2F** Roof beacons - Two amber front
- BEACOA2R** Roof beacons - Two amber rear roof-mounted on accessory bracket
- BEACON-P** Roof beacons - wiring preparation only
- BEACONA4** Roof beacons - Four amber - two front/ two rear
- CABPT-R1** Single outlet for roof mounted accessories
- CABPT-R2** Twin outlets for roof mounted accessories.
- SPOTP-F** Spotlamp preparation in front, max 280W
- SPOTP-R** Spotlamp preparation on roof, max 280W
- SPOTP-RF** Spotlamp preparation on cab roof and in cab front, max 2x280W
- ROS-IL2** Preparation kit for illuminated roof sign with switch loose in cab, fit after registration
- CSGN-ENG** Engine size and power headboard logo
- CSGN-GTR** "Globetrotter" headboard logo
- HORN-F1S** Horn - Air single tone - chassis mounted
- HORN-R2S** Horn - Air - Two roof-mounted
- ANT-CBR** Roof mounted antenna for CB radio, single aerial
- ACCBP-AP** Front, middle & rear roof mounted accessory brackets
- ACCBP-F** Front roof mounted accessory bracket
- ACCBP-FM** Front & middle roof mounted accessory brackets
- ACCBP-FR** Front & rear roof mounted accessory brackets
- ACCBP-M** Middle roof mounted accessory bracket
- ACCBP-R** Rear roof mounted accessory bracket
- ACCBP-RM** Rear & middle roof mounted accessory brackets
- STUC-B** Left and right storage compartments under cab
- STUC-L** Left storage compartment under cab
- STUC-R** Right storage compartment under cab
- REFS-TW** White cab conspicuity markings by packed in cab
- REFS-TY** Yellow cab conspicuity markings by packed in cab
- SWL-2RW** Chassis-mounted working lamps - Two white rear-mounted LED lamps
- SWL-4W** Chassis-mounted working lamps - Four white front and rear-mounted LED lamps
- SWL-PK** Chassis-mounted working lamps - Side work lamp preparation and 2 position switch - Max load 280W
- WLC-H2W** Two H3/70W white working lamps high mounted on the back of cab
- WLC-PKCH** Working lamp back of cab - Preparation kit - cables and switch
- WLC-PKH** Preparation kit, cables and switch for high mounted working lamps back of cab
- WLC-PKL** Preparation kit, cables and switch for low mounted working lamps back of cab
- WLC-PKLH** Preparation kit - cables and switch for low and high mounted working lamps back of cab.
- ECBB-HIG** Body builder electrical centre with body builder module
- BBCHAS1** One 7-pole connector for Body builder interface
- BBCHAS3** Three 7-pole connectors for Body builder interface
- BEPR-T2** Body builder electrical software preparation for tipper with remote control
- EXSTER** External steering control - Volvo dynamic steering and bodybuilder module prepared for external control system, installed and computer by bodybuilder
- TD-LED** Trailer detection with LED sensing
- FRFS-BS** Frame rail free space on both sides to give space for crane legs or other equipment.
- FBA-BTF** Lower front body attachments for torsionally flexible - platform body
- FBA-BTSF** Lower front body attachments for torsionally semi-flexible body - box or curtainsider
- HBA-FSFB** Holes for body attachments - flexible/semi-flexible body
- HBA-SB** Holes for body attachments - stiff body
- RBA-T2** Lower rear body attachments for helper frame
- CRANEPK1** Crane plates mounted to frame, for cranes up to 10 tonne metre capacity
- CRANEPK2** Crane plates mounted to frame, for cranes up to 20 tonne metre capacity
- CRANEPK4** Crane plates mounted to frame, for cranes up to 40 tonne metre capacity
- AUXL-SPK** Electrical preparation kit - wiring and switch for snow plough lights
- TAILPRE2** Tail lift preparation kit, wireless remote operation
- TAILPREP** Taillift preparation kit - cab switch and warning in driver display
- AESW2** Two Body builder bistable electrical switches (marked AUX1 / AUX2)
- AESW2PK** 2 Body builder bistable el.switches (marked AUX1/AUX2) and prep. for 4 more switches
- AUXSW-4** Wiring for 4 extra switches (from Body builder electrical centre to switch positions)

DELIVERY SERVICES

- TGW-4GWL** Telematics gateway - GSM/GPRS/4G modem, LTE & WLAN
- FMS-PK** Fleet Management System gateway
- DRUT2** Driver utility app - "My Truck" - two-year subscription For mobile phone, tablet, with android and IOS systems. Only available with Volvo Connect subscription

SUPERSTRUCTURE PREPARATIONS

- SRWL-PK** Chassis-mounted working lamps - Side work and reverse lamp preparation and 3 position switch - Max load 280W
- SWL-2FW** Chassis-mounted working lamps - Two white front-mounted LED lamps



Volvo Truck Corporation
volvotrucks.com